



Modulator[®] Speaker Array

Model MOD Series

DESIGNED FOR ALERT/ WARNING AND PUBLIC ADDRESS OVER A WIDE AREA

- 360° sound coverage with no variation in the horizontal plane
- Multiple tones and public address
- Excellent frequency response
- Produces 106dBc to 125dBc @ 100'
- Each module has four 100-watt drivers
- Operates with UV controller

Federal Signal's Modulator[®] Speaker Array Series consists of a family of six electronic sirens. These innovative omni-directional sirens are capable of producing high-intensity warning signals over a wide area. This efficient design enables these sirens to produce a high sound level, while making only moderate demands on the power source.

Each Modulator Speaker Array is made up of aluminum modules that utilize four 100 watt drivers. Speaker arrays require a siren control unit/battery cabinet (purchased separately).

The Modulator Speaker Array provides a flat frequency response from 200 to 2000Hz for excellent voice reproduction or warning signals such as: Wail (attack), Pulsed Steady, Steady (alert), Alternating Steady, Alternating Wail, and Pulsed Wail – which are produced by the modulator siren control unit.

Federal Signal's Modulator Speaker Array is intended for outdoor applications. Industrial sites such as refineries, chemical plants, power plants, or tank farms are typical applications for these omni-directional electronic arrays.

Model	Active Modules	Watts	dBc @ 100'	Effective Range @ 70dBc
MOD1004	1	400	106	1,200 Feet
MOD2008	2	800	112	1,800 Feet
MOD3012	3	1200	115	2,400 Feet
MOD4016	4	1600	118	2,800 Feet
MOD5020	5	2000	120	3,100 Feet
MOD6024	6	2400	121	3,400 Feet



MODULATOR® SPEAKER ARRAY (MOD)

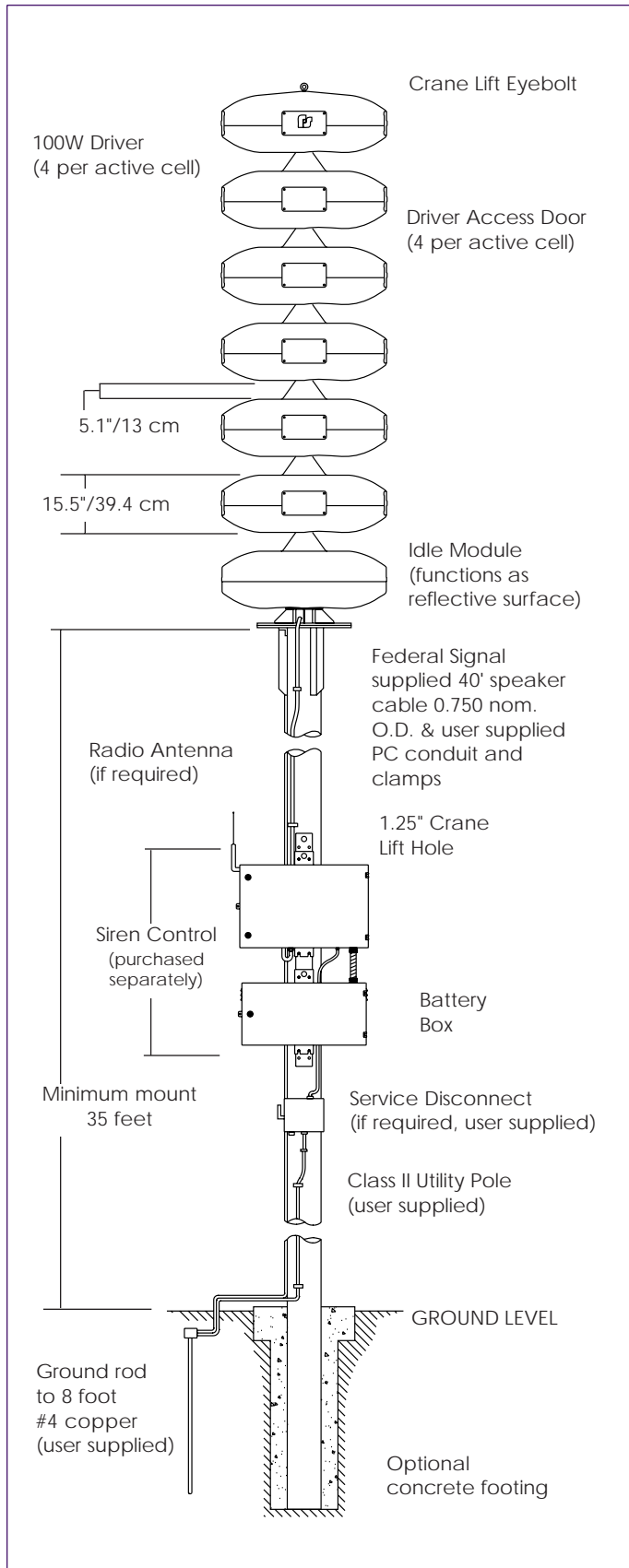

SPECIFICATIONS

Frequency Response: 200-2000Hz ± 1dB
 Horizontal Coverage: 360° ± 1dB

Wind Loading @ 110mph wind velocity¹:

MOD1004	360 lbs.
MOD2008	540 lbs.
MOD3012	720 lbs.
MOD4016	900 lbs.
MOD5020	1080 lbs.
MOD6024	1260 lbs.

¹Wind loading is the calculated force of wind at 110mph (shoreline), exposure D (flat, unobstructed coastal areas) on frontal area 4.64 ft. per American National Standards Institute A58.1*Minimum design loads for buildings and other structures.*

Model	Height (in./cm)	Net Wt. (lbs./kg)	Shipping Wt. (lbs./kg)
MOD1004	43.17"/109.65	181/82	350/158.8
MOD2008	63.7"/161.8	296/134.3	400/181.4
MOD3012	84.3"/214.1	411/186.4	600/272.2
MOD4016	105"/266.7	526/238.6	750/340.2
MOD5020	125.5"/318.8	641/290.8	1000/453.6
MOD6024	146"/370.8	760/344.7	1270/576

HOW TO ORDER

- Specify speaker array model number – each speaker array model must be ordered with a specific corresponding UV and Amplifier.

SPEAKER CONTROLLER

MOD1004	UV + 1 UV400
MOD2008	UV + 2 UV400
MOD3012	UV + 3 UV400
MOD4016	UV + 4 UV400
MOD5020	UV + 5 UV400
MOD6024	UV + 6 UV400

- Specify optional CABEX 10' cable extension²
- Call the factory for assistance in specifying an outdoor warning system

²40 feet of cable is supplied with siren. Extension cable in 10 foot increments is also available. Mounting the UV controller further than 100 feet is not recommended (further mounting may decrease power output).

REPLACEMENT PARTS

Description	Model
Driver, 100 watt	8570063A