



Litestak[®] Homeland Security Status Indicator

Model LSHLS

NOTIFY HOMELAND SECURITY STATUS CHANGES

- Available in 24VDC and 120VAC
- Five lens colors
- Surface mount and integrated 3/4-inch pipe mount
- Available with LED or Incandescent Lamps
- UL and cUL Listed
- Made in the USA

Federal Signal, the world's largest prime manufacturer of audible and visual signaling for industry has introduced a Homeland Security Advisory Status Indicator. The LiteStak is an effective tool for communicating the Threat Conditions as outlined in the Homeland Security Presidential Directive; Low (Green), Guarded (Blue), Elevated (Yellow), High (Orange) and Severe (Red). The LiteStak is suitable for use in industrial, commercial and municipal environments.

Each light module produces 360 degrees of light dispersion. Optical cross-hatching ensures a lens-filling distribution of light that is free of "hot spots". Each module of the LiteStak can be set up for either steady burning or flashing operation (with relays, flashers or PLCs). The lens of each module snaps on for quick and easy lamp maintenance.

Lamps choices include a rugged 25-watt incandescent bulb or a lifetime guaranteed 100,000 hour LED lamp. The LiteStak can be installed easily in a surface mount or a 3/4" NPT pipe mount configuration. The choice of operating voltages includes 24VDC and 120VAC for incandescent models and 24VDC and 120VAC for LED models.

| Model | Voltage | Operating Current | Mount |
|-----------|---------|-------------------|--------------|
| LSHLS | 24VDC | 0.76 amps | Pipe/Surface |
| LSHLS | 120VAC | 0.13 amps | Pipe/Surface |
| LSHLS-LED | 24VDC | 0.20 amps | Pipe/Surface |
| LSHLS-LED | 120VAC | 0.04 amps | Pipe/Surface |



HOMELAND SECURITY STATUS INDICATOR (LSHLS)

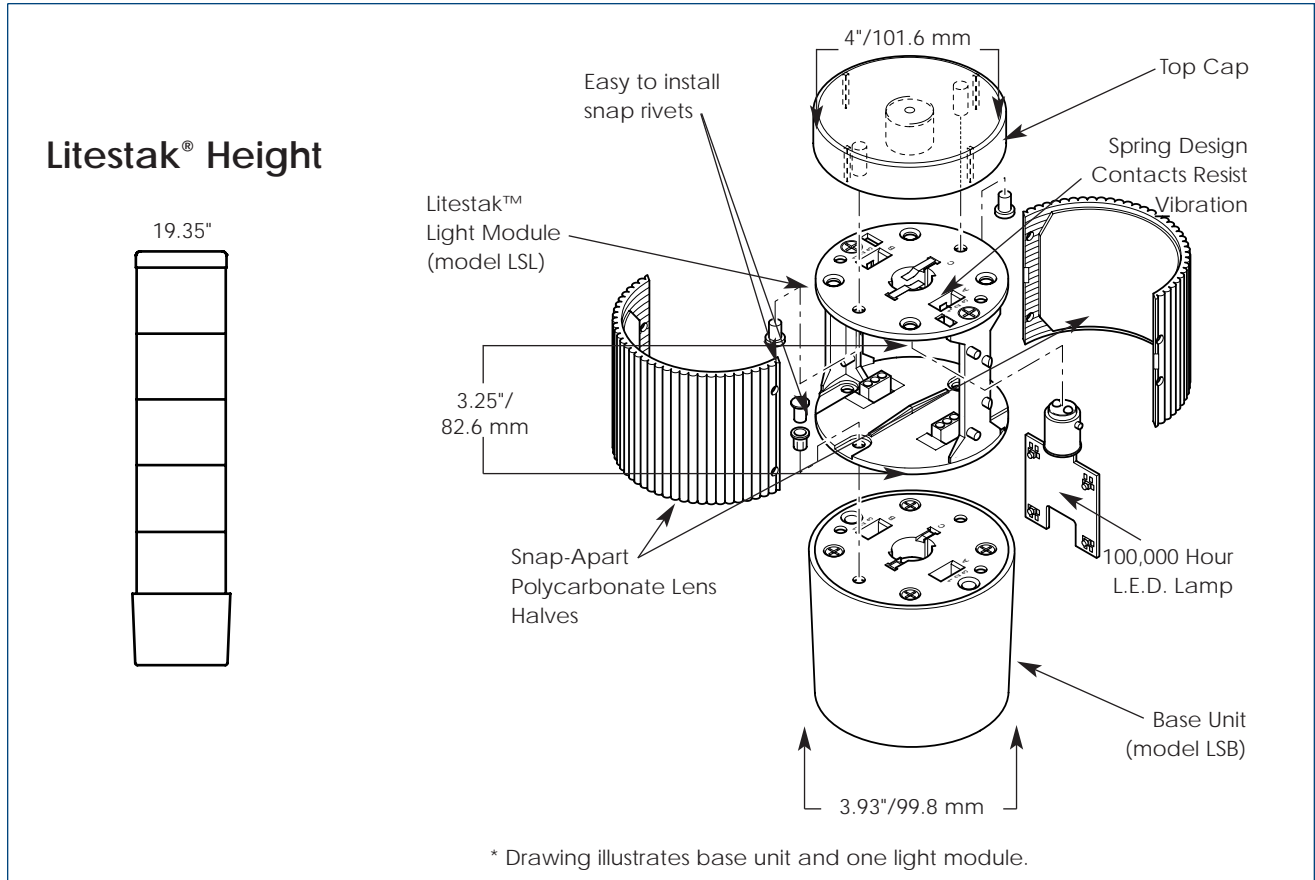

SPECIFICATIONS

| | | |
|---------------------------|----------------|---------------|
| Lamp Life, Incandescent*: | 7,000 Hours | 7,000 Hours |
| Lamp Life, L.E.D*: | 100,000 Hours | 100,000 Hours |
| Operating Temperature: | -32°F to 120°F | -36°C to 49°C |
| Net Weight: | 3.0 lbs. | 1.4 kg |
| Shipping Weight: | 4.8 lbs. | 2.2 kg |
| Height: | 19.35" | 491.5 mm |
| Diameter: | 3.93" | 99.8 mm |

* Optimal hours under ideal conditions.

HOW TO ORDER

- Specify model, voltage and lamp style (incandescent or LED)
- Please refer to Model Number Index LSL/LSB beginning on page 370

REPLACEMENT PARTS

| <u>Description</u> | <u>Part Number</u> | <u>Description</u> | <u>Part Number</u> |
|------------------------|--------------------|---------------------------|--------------------|
| Lens Kit, Amber | K8447014A-02 | Incandescent Lamp, 24VDC | K8107210A |
| Lens Kit, Blue | K8447014A-04 | Incandescent Lamp, 120VAC | K8107194A |
| Lens Kit, Green | K8447014A-01 | LED Lamp, Amber | LED-024ASB |
| Lens Kit, Orange | K8447014A-08 | LED Lamp, Blue | LED-024BSB |
| Lens Kit, Red | K8447014A-03 | LED Lamp, Green | LED-024GSB |
| Snap Rivets, 25 pieces | K7099A112A-01 | LED Lamp, Orange | LED-024ASB |
| Cap Kit | K8447009E | LED Lamp, Red | LED-024RSB |