



Fireball® 2 Explosion-Proof Strobe Warning Light

Model FB2PSTX and FB2PSTX-I

DESIGNED FOR USE IN EXPLOSION-PROOF ATMOSPHERES

- Available in 12-24VDC, 120VAC and 230-240VAC
- Five lens colors
- 10,000 hour strobe tube
- Ceiling mount standard; other options available
- UL and cUL Listed
- Marine Listed
- Type 4X, IP66 enclosure

Federal Signal's FB2PSTX explosion-proof strobe light is a compact unit that produces a "lightning bolt" flash of light. Measuring 13.69" (348mm) high and 7.44" (189mm) in diameter, the FB2PSTX is available in 12-24VDC, 24VDC, 120VAC and 230-240VAC. These strobe lights are well suited for a wide range of explosion-proof warning light applications.

All models are UL and cUL Listed for indoor/outdoor and marine use. This model is UL Listed for Class I, Division 1, Groups C and D; Class I, Division 2, Groups A, B, C and D; Class II, Division 1, Groups E, F and G; Class II, Division 2, Groups F and G; and Class III.

Model FB2PSTX has a self-contained power supply. The copper-free aluminum finned base dissipates heat and ensures long life. The outer dome is made of tempered glass. Polycarbonate inner lenses are available in amber, blue, clear, green and red. A rugged ceiling mount fixture is standard; optional wall mounts and dome guards are also available.

The FB2PST-I features a voltage in-rush limiting PCB design that provides greater compatibility with factory automation control systems and less electrical interference with in-rush sensitive devices.

The Model FB2PSTX is suited for any application where a superior visual signal is needed and is especially effective for warning of industrial hazards, process control, status indication or in areas with high ambient noise levels.

Model	Voltage	Operating Current	Flash Rate/Minute
FB2PSTX	12-24VDC	1.70-0.70 amps	80
FB2PSTX-I	24VDC	0.70 amps	80
FB2PSTX	120VAC 50/60HZ	0.25 amps	80
FB2PSTX	230-240VAC 50/60HZ	0.20 amps	80



EXPLOSION-PROOF STROBE LIGHT (FB2PSTX)

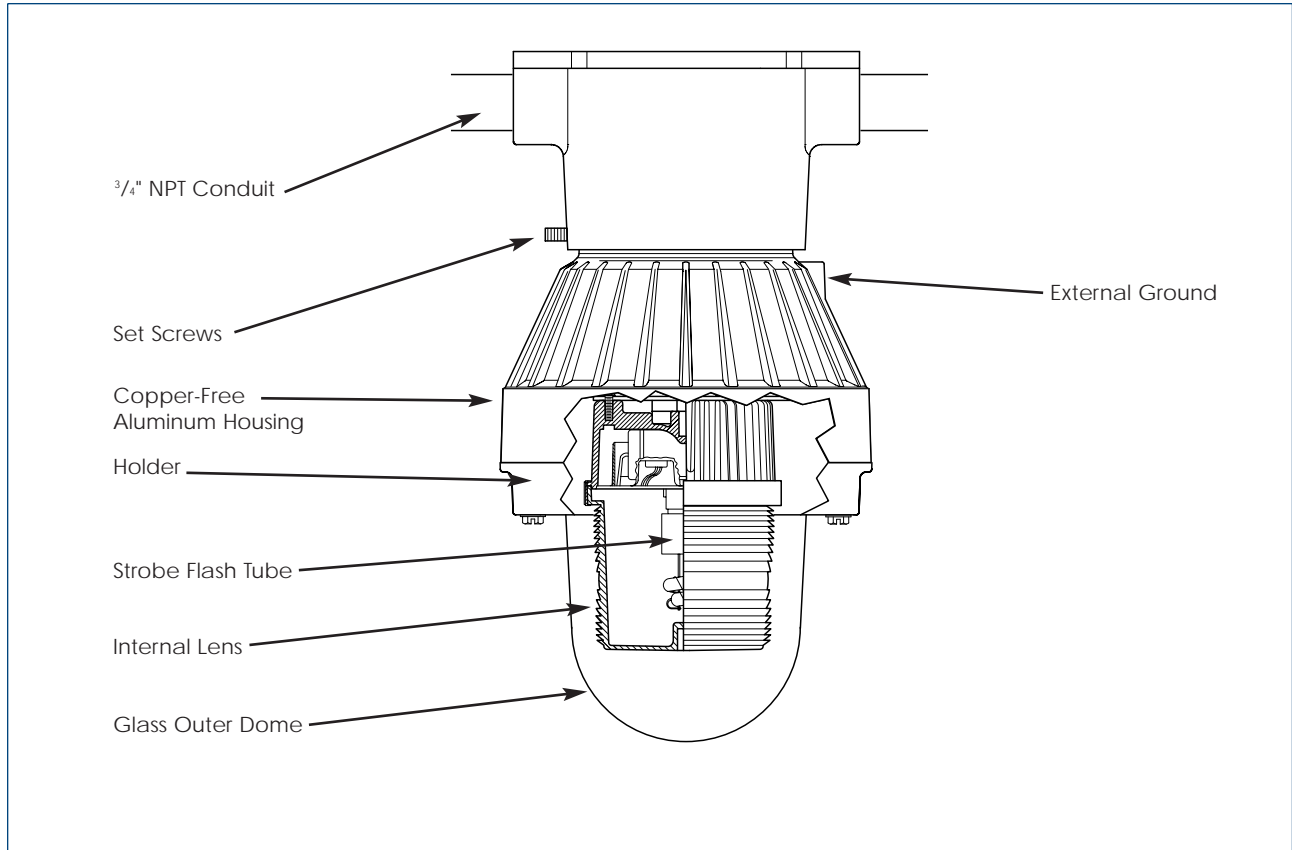

SPECIFICATIONS

Operating Temp.:	-13°F to 149°F	-25°C to 65°C
Net Weight:	9.6 lbs.	4.35 kg
Shipping Weight:	13.1 lbs.	5.94 kg
Height:	13.69"	348 mm
Diameter:	7.44"	189 mm

HOW TO ORDER

- Specify model, voltage and color
- Specify options:
Wall Mount (WMXC)
Dome Guard (DGFBX)
- Please refer to Model Number Index FB2PSTX beginning on page 373

REPLACEMENT PARTS

<u>Description</u>	<u>Part Number</u>
Inner Lens, Amber	K8550292A-02
Inner Lens, Blue	K8550292A-01
Inner Lens, Clear	K8550292A
Inner Lens, Green	K8550292A-04
Inner Lens, Red	K8550292A-03
Outer Dome Assembly	K8550272A-01
PC Assembly, 12-24VDC	K2001202C
PC Assembly, 120VAC	K200D866G
PC Assembly, 240VAC	K200D866G-01
Strobe Tube	K8107177A