

# Fireball® Strobe Warning Light

## Model FB2PST and FB2PST-I



### LIGHT DUTY STROBE LIGHT

- Available in 12-24VDC, 120VAC and 240VAC
- Six dome colors
- 10,000 hour strobe tube
- Integrated 1/2" pipe and surface mount
- UL and cUL Listed, CSA Certified for indoor/outdoor use
- Type 4X, IP66 enclosure

Federal Signal's brightest and most compact strobe light, the Fireball® emits a powerful "lightning bolt" flash of light. Approximately five inches tall and four inches in diameter and rated at 300 effective candlepower, the Fireball is an economical solution to a wide variety of stationary and vehicular warning requirements. The Fireball is available in 12-24VDC, 24VDC, 120VAC and 240VAC. All models are UL Listed and CSA Certified. The FB2PST is available in six colors – amber, blue, clear, green, magenta, and red.

The 24VDC Model FB2PST-I features a voltage in-rush limiting PCB design that provides greater compatibility with factory automation control systems and less electrical interference with in-rush sensitive devices.

The Fireball features a unique dome that twists off easily for quick dome and lamp replacements. The newly redesigned base features an integrated 1/2-inch pipe mount base as well as the three holes required for surface mount configurations. Black epoxy paint is electrostatically applied to the base for superior corrosion resistance. The Fireball dome and base design provides a watertight, dust-tight and corrosion resistant Type 4X rating.

The FB2PST is designed for stationary pipe and surface mount applications.

The Fireball can be used in any application where a superior visual signal is needed. It is especially effective in the warning of industrial hazards, process control, status indication and in areas with high ambient noise levels.

Federal Signal's Fireball Strobe is a very low-maintenance warning light for industrial applications where a vibration-resistant light is required to signal an emergency or process status.

Model	Voltage	Operating Current	Flash Rate/ Minute	Candlepower Peak <sup>1</sup>	ECP <sup>2</sup>	Mount
FB2PST	12-24VDC	1.70-0.70 amps	80	1,000,000	300	1/2" Pipe/Surface
FB2PST-I	24VDC	0.70 amps	80	1,000,000	300	1/2" Pipe/Surface
FB2PST	120VAC 50/60Hz	0.25 amps	90	1,000,000	300	1/2" Pipe/Surface
FB2PST	240VAC 50/60Hz	0.20 amps	90	1,000,000	300	1/2" Pipe/Surface

<sup>1</sup> Peak candlepower is the maximum light intensity generated by a flashing light during its light pulse

<sup>2</sup> ECP (Effective Candlepower) is the intensity that would appear to an observer if the light were burning steadily



## FIREBALL® STROBE WARNING LIGHT (FB2PST)

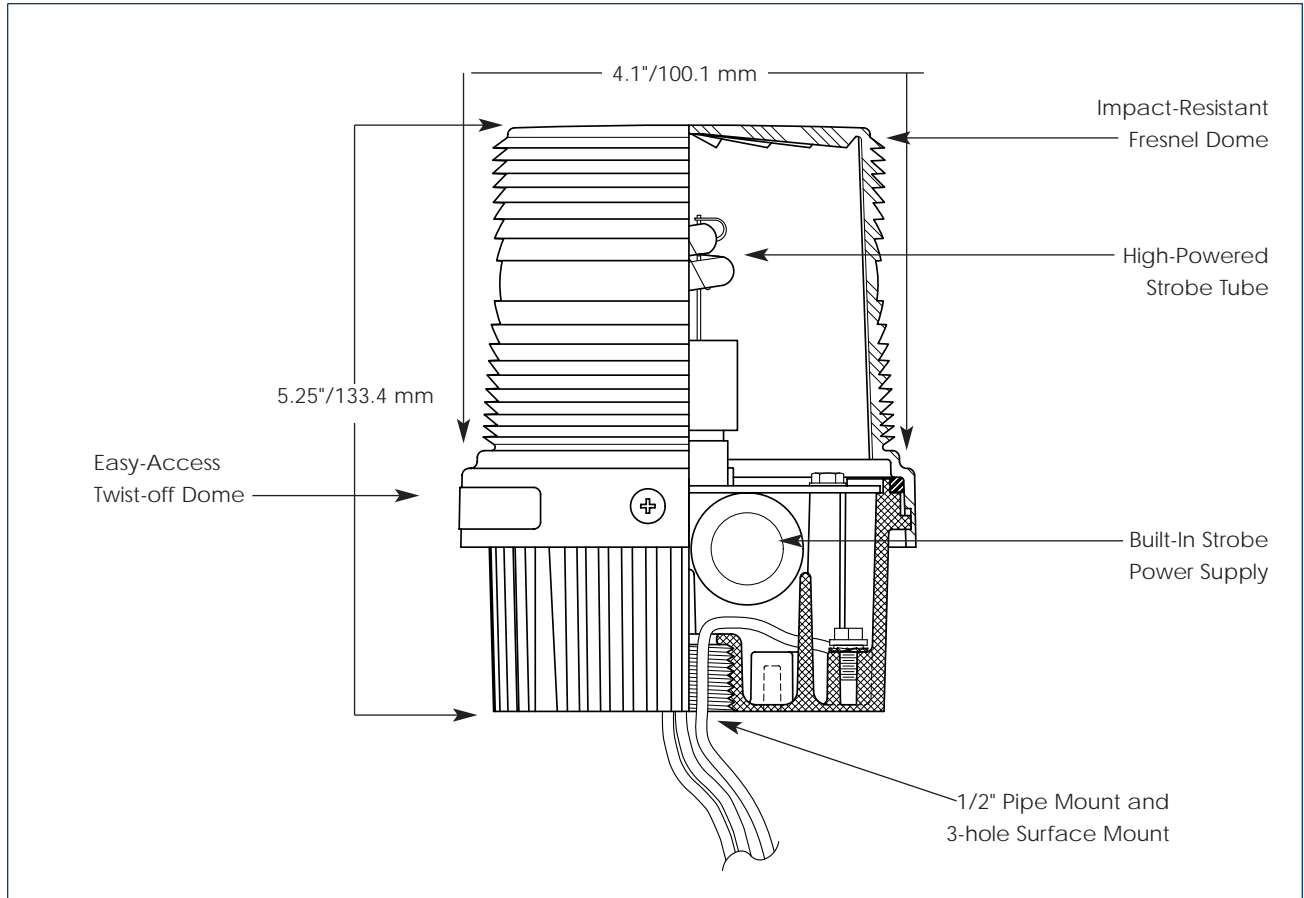

### SPECIFICATIONS

Lamp Life*:	10,000 Hours	10,000 Hours
Lamp Style:	Strobe	Strobe
Operating Temperature:	-31°F to 150°F	-35°C to 66°C
Net Weight:	1.45 lbs.	0.7 kg
Shipping Weight:	1.7 lbs.	0.8 kg
Height:	5.25"	133.4
Diameter:	3.94"	100.1

\* Optimal hours under ideal conditions.

### HOW TO ORDER

- Specify model, voltage and color
- Specify options:  
Corner Bracket (LCMB2)\*  
Wall Bracket (LWMB2)\*
- Please refer to Model Number Index FB2PST beginning on page 372

\* Not Type 4X rated.

### REPLACEMENT PARTS

<u>Description</u>	<u>Part Number</u>	<u>Description</u>	<u>Part Number</u>
Dome, Amber	K8550320A	PC Assembly, 12-24VDC	K2001202C
Dome, Blue	K8550320A-01	PC Assembly, 120VAC	K200D866G
Dome, Clear	K8550320A-02	PC Assembly, 240VAC	K200D866G-01
Dome, Green	K8550320A-03	Strobe Tube, Series A, A1, A2, A3	Call Factory
Dome, Red	K8550320A-04	Strobe Tube, Series A4, A5, B	K8107177A
Dome, Magenta	K8550320A-05	120VAC Fuse	K148A155A-01