



Vehicular Back-up Alarm

Model 252

SIGNALS WHEN A VEHICLE IS BACKING-UP

- Rugged weatherproof housing
- Solid-state, epoxy-sealed electronics
- Operates within the 12VDC to 48VDC range used in most vehicles
- Produces 97dB @ 4' (109dB @ 1m)
- Universal mounting
- Conforms to SAE J994 sound level Type C requirements
- Type 4X enclosure

Federal Signal's Model 252 back-up alarm is a solid state audible warning device enclosed in a weatherproof housing. The alarm produces a horn tone of 97dB at four feet (109dB at 1m) and sounds at approximately 60 times per minute with equal on and off pulses. Model 252 conforms to SAE (Society of Automotive Engineers) J994 Sound Level Type C.

Federal Signal's Model 252 housing is constructed of black glass-reinforced plastic and comes equipped with universal mountings for easy installation. When properly installed, this unit is weatherproof, dust-proof and not adversely affected by the steam cleaning of vehicles.

This rugged device is polarity protected and will operate within a range of 12VDC to 48VDC.

Model 252 is designed for use in a wide variety of vehicles that operate in populated areas — both indoors and out. This alarm is ideal for use on forklifts, tractors, waste disposal vehicles, dump trucks, earth moving equipment or any other vehicle that operates near people.

Federal Signal's Model 252 Vehicular Back-up Alarm is an economical life-safety device designed to prevent accidents.

Model	Voltage	Operating Current	Decibels @	
			4'	1m
252	12VDC to 48VDC	0.20 amps	97	109



BACK-UP ALARM (252)

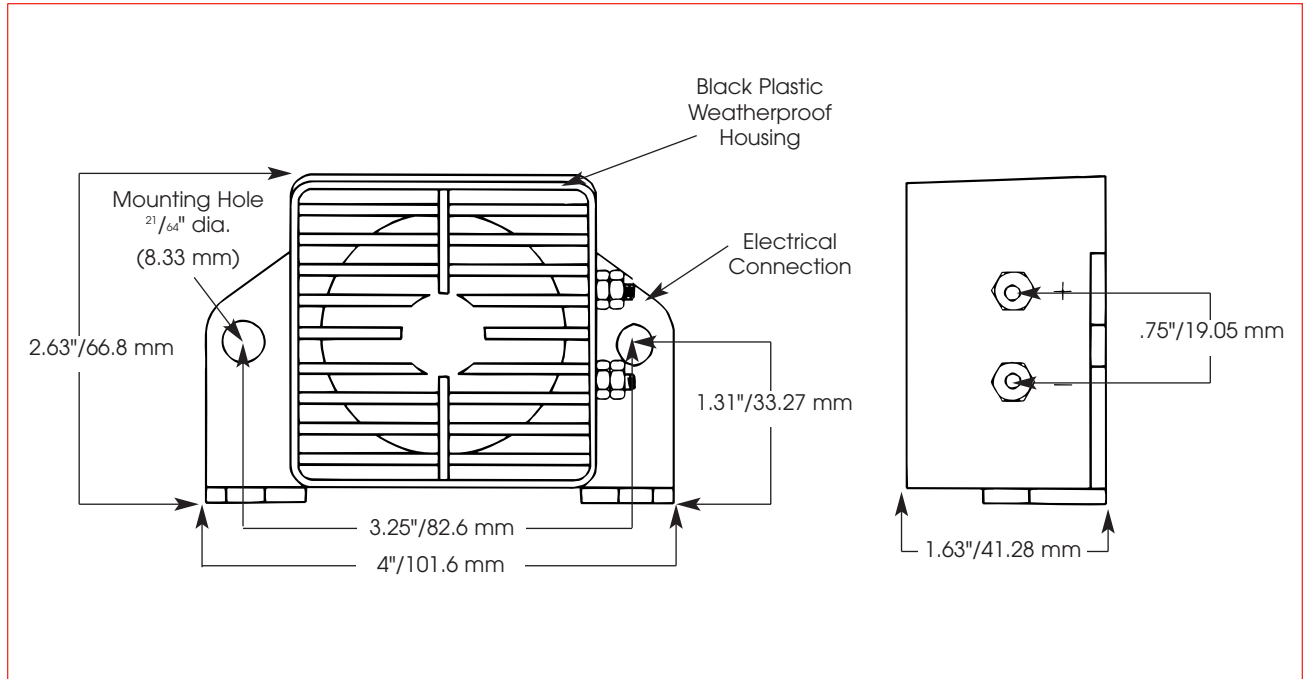

SPECIFICATIONS

Operating Temperature:	-40°F to 167°F	-40°C to 75°C
Net Weight:	0.3 lbs.	7.62 kg
Shipping Weight:	0.4 lbs.	10.16 kg
Height:	2.63"	66.8 mm
Width:	4.0"	101.6 mm
Depth:	1.63"	41.28 mm

HOW TO ORDER

- Specify model number and voltage
- Please refer to Model Number Index 252 beginning on page 381