



Electraray® Hazardous Location L.E.D. Steady Burn Warning Light

Model 225XL

L.E.D.-BASED WARNING LIGHT FOR HEAVY-DUTY INDUSTRIAL APPLICATIONS

- Available in 24VDC and 120VAC
- Five lens/lamp colors
- 100,000-hour, vibration-resistant L.E.D. lamp
- 1/2-inch pipe mount
- UL and cUL Listed, CSA Certified for Class 1, Division 2 applications
- Type 4X, IP66 enclosure

Federal Signal's Electraray® Model 225XL hazardous location L.E.D. light is a long-life, vibration-resistant warning light. Model 225XL is available in 24VDC and 120VAC.

The Model 225XL has been certified by UL as meeting Type 4X watertight and corrosion-resistant requirements, and is rated for Division 2 applications. This hazardous location warning light has a black polyurethane-coated base and the inner fresnel lens is available in five colors — amber, blue, clear, green and red. The clear polycarbonate outer dome can be quickly removed for access while changing the lamp or inspecting the unit.

Federal Signal's 100,000-hour L.E.D. lamps come in five colors as well — amber, blue, clear, green and red.

The 225XL is UL Listed and CSA Certified for Class I, Division 2, Groups A, B, C, and D; Class II, Division 2, Groups F and G; and Class III.

The Federal Signal Model 225XL is ideal for wet, corrosive atmospheres like those found in food processing industries or anywhere a vibration-resistant visual signal is needed.

Model	Voltage	Operating Current	Mount
225XL	24VDC	0.08 amps	1/2 Pipe
225XL	120VAC 50/60Hz	0.04 amps	1/2 Pipe



ELECTRARAY® HAZARDOUS LOCATION L.E.D. LIGHT (225XL)

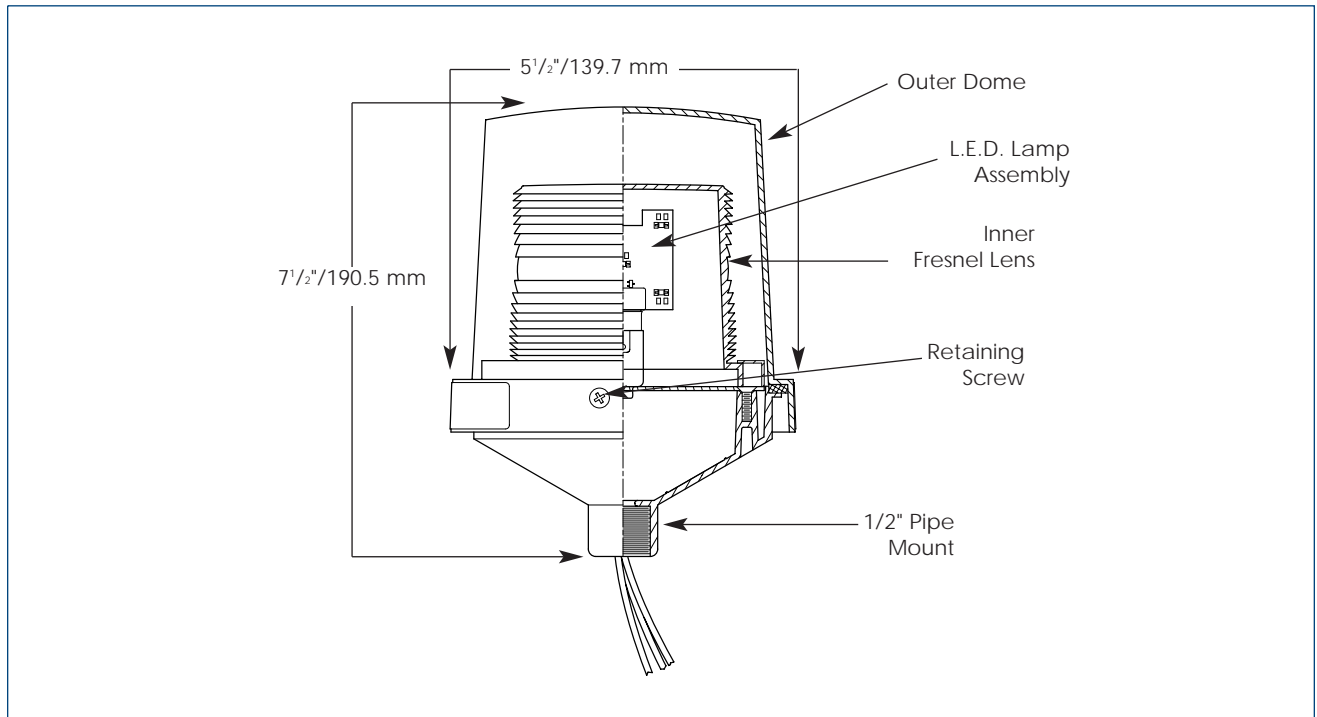

SPECIFICATIONS

Lamp Life*:	100,000 hours	100,000 hours
Lamp Style:	L.E.D.-based Lamp	L.E.D.-based Lamp
Operating Temperature:	-31°F to 150°F	-35°C to 66°C
Net Weight:	2.2 lbs.	1.0 kg
Shipping Weight:	2.25 lbs.	1.0 kg
Height:	7.5"	190.5 mm
Diameter:	5.5"	139.7 mm

* Optimal hours under ideal conditions.

HOW TO ORDER

- Specify model, voltage and color
- Please refer to Model Number Index 225XL beginning on page 372

REPLACEMENT PARTS

<u>Description</u>	<u>Part Number</u>	<u>Description</u>	<u>Part Number</u>
Exterior Dome, Clear	K8444D219C-04	L.E.D. Lamp, Amber 24VDC	LED-024ASB
Interior Lens, Clear	K8550C095A	L.E.D. Lamp, Blue 24VDC	LED-024BSB
Interior Lens, Blue	K8550C095A-01	L.E.D. Lamp, Clear 24VDC	LED-024CSB
Interior Lens, Amber	K8550C095A-02	L.E.D. Lamp, Green 24VDC	LED-024GSB
Interior Lens, Red	K8550C095A-03	L.E.D. Lamp, Red 24VDC	LED-024RSB
Interior Lens, Green	K8550C095A-04	L.E.D. Lamp, Amber 120VAC	LED-120ASB
		L.E.D. Lamp, Blue 120VAC	LED-120BSB
		L.E.D. Lamp, Clear 120VAC	LED-120CSB
		L.E.D. Lamp, Green 120VAC	LED-120GSB
		L.E.D. Lamp, Red 120VAC	LED-120RSB