

MODEL 371DST
INSTALLATION AND SERVICE INSTRUCTIONS
FOR COMMANDER®
MODEL 371DST STROBE LIGHTS

Address all communications and shipments to:



FEDERAL SIGNAL CORPORATION

**INSTALLATION AND SERVICE INSTRUCTIONS
FOR COMMANDER®
MODEL 371DST STROBE LIGHTS**

**SAFETY MESSAGE TO INSTALLERS,
USERS AND MAINTENANCE PERSONNEL**

It is important to follow all instructions shipped with this product. This device is to be installed by a trained electrician who is thoroughly familiar with the National Electric Code/Canadian Electric Code and will follow the NEC/CEC Guidelines as well as local codes.

The selection of mounting location for the device, its controls and the routing of the wiring is to be accomplished under the direction of the facilities engineer and the safety engineer. In addition, listed below are some other important safety instructions and precautions you should follow:

- Read and understand all instructions before installing or operating this equipment.
- To reduce the risk of ignition of hazardous atmospheres, disconnect the fixture from the supply circuit before opening. Keep tightly closed when in operation.
- The strobe housing is not be used as a raceway for through branch circuit conductors.
- After installation, ensure that the threaded dome ring joint is fully engaged.
- After installation, test the light system to ensure that it is operating properly.
- After testing is complete, provide a copy of this instruction sheet to all operating personnel.
- Establish a procedure to routinely check the light installation for integrity and proper operation.

Failure to follow all safety precautions and instructions may result in property damage, serious injury, or death to you and others.

I. INSTALLATION

A. Unpacking.

After unpacking the light, examine it for damage that may have occurred in transit. If the equipment has been damaged, do not attempt to install or operate it. File a claim immediately with the carrier stating the extent of the damage. Carefully check all envelopes, shipping labels, and tags before removing or destroying them.

B. Mounting (see figure 1).

CAUTION

To reduce the risk of fire or explosion, do not install in hazardous location if the operating temperature exceeds the hazardous atmosphere's ignition temperature. Refer to the product nameplate for operating temperature markings.

The Model 371DST lights are designed for mounting on a flat horizontal surface or on a 1" NPT pipe. For surface mounting on solid substrates, a separately purchased Model 371BRCKT (3-point mounting bracket) may be used. When using Model 371BRCKT, the bottom 1" NPT conduit entry of the light must be plugged with the 1" NPT close-up plug provided with the kit. If conduit side entry is to be used, disassemble light as described in section ID.1 and remove knockout with a blunt tool prior to mounting light. Use a file to remove excess flash around the knockout.

1. Pipe Mounting.

- a. Attach light to pipe by turning clockwise.
- b. Refer to section D for information on making electrical connections.

2. Surface Mounting.

- a. Using the gasket as a template, scribe four drill position marks on the mounting surface. Drill a 9/32" (7.1mm) diameter hole at each of the outside drill position marks for mounting. Drill or punch a 1-3/8" (34.9mm) diameter hole at the center drill position mark for wire entry.
- b. Attach 1" NPT conduit or suitable user supplied 1" NPT hub or connector to conduit entrance in bottom of light.
- c. Set light on gasket and attach to the mounting surface using the provided 1/4" screws and washers.
- d. Refer to section D for information on making electrical connections.

C. Specifications.

Operating Voltage	12-24VDC	120 VAC 50/60 Hz	230-240 VAC 50/60 Hz
Operating Current	2.10A	0.60A	0.30A
Energy Output	10.0 Joules	10.0 Joules	10.0 Joules
Flash Rate	72-88 FPM	72-88 FPM	72-88 FPM
Operating Temperature	-31°F to 104°F (-35°C to 40°C)	-31°F to 104°F (-35°C to 40°C)	-31°F to 104°F (-35°C to 40°C)
Approvals	UL, cUL	UL, cUL	UL, cUL
Environmental Ratings	Type 4X, IP66	Type 4X, IP66	Type 4X, IP66

D. Electrical Connections (see figure 2).

The Model 371DST comes assembled from the factory with three color-coded leads for wiring to a junction box. If desired, the factory leads can be removed and the supply connections can be directly made to the terminal block located on the backside of the mounting bracket as described below.

WARNING

To avoid electrical shock hazards, do not connect to supply circuit when power is applied.

1. Disassemble the light as follows:
 - a. Remove dome assembly by grasping the die-cast ring attached to the dome and turning it counter-clockwise.
 - b. Remove three #10 hex head screws that secure strobe-spinning assembly to housing.
 - c. Remove strobe-spinning assembly.
 - d. If desired, remove the factory field wiring leads from the terminal block.
2. If conduit side entry is to be used, attach either Myers STNTB-2 or T&B H075-TBH 3/4" N.P.T. conduit hub with 3/4" N.P.T. close nipple (all user-supplied) to housing and tighten securely. When using side entry, the bottom 1" NPT conduit entry must be plugged with a UL listed threaded plug (user-supplied).
3. Route supply wires (10 AWG to 16 AWG) into the housing.

- Strip a maximum of .28" (7 mm) of wire insulation from the ends of the power leads. Connect wires to terminal block by inserting the stripped ends of the wire into the connector as far as they can travel and tightening the clamping screw (max. tightening torque = 7.0 in-lbs (.8 N-m)).

NOTE

For DC models, polarity must be observed for proper operation. Connect the positive power supply lead to the (+) terminal and the negative power supply lead to the (-) terminal.

- Connect earth ground to terminal block and green ground screw located in housing.
- Re-assemble the light and test for proper operation.

II. MAINTENANCE.

SAFETY MESSAGE TO MAINTENANCE PERSONNEL

Listed below are some important safety instructions and precautions you should follow:

- Read and understand all instructions before operating this system.
- Any maintenance to the light system must be done with the power turned off.
- Any maintenance to the light system must be performed by a trained electrician in accordance with NEC/CEC Guidelines and local codes.
- Never alter the unit in any manner. Safety may be endangered if additional openings or other alterations are made to units.
- The nameplate, which contains cautionary or other information of importance to maintenance personnel, should not be obscured.
- If the dome is damaged in any way, the complete dome assembly **MUST** be replaced.
- After performing any maintenance, test the light system to ensure that it is operating properly.

A. Flashtube Replacement (see figure 3).

After extended operation, occasionally check for flash tube degradation. Should the flash tube misfire, have a noticeable decrease in light output, glow continuously or darken- replacement is necessary.

WARNING

HIGH VOLTAGES ARE PRESENT INSIDE THE LIGHT ASSEMBLY. WAIT AT LEAST 5 MINUTES AFTER SHUTTING OFF POWER BEFORE SERVICING THIS UNIT.

To replace strobe tube, proceed as follows:

1. Remove the dome assembly by grasping the die-cast ring attached to the dome and turning it counter-clockwise. If difficulty occurs removing the dome assembly, place a screwdriver blade against one of the four bosses on the die-cast ring attached to the dome. Gently tap the screwdriver handle to loosen the dome assembly from the housing.

WARNING

To maintain the watertight enclosure, do not damage dome or threads while disassembling or reassembling the unit. Lubricated threaded joints exposed for long periods of time may attract small particles of dirt or other foreign materials. Re-assemble joint immediately after performing maintenance.

2. Remove the two #8 screws retaining the fresnel lens to its mounting base and lift the lens off the metal spinning.

3. Carefully remove the flash tube from its socket by grasping the connector and lifting upwards using a slight rocking motion.
4. See replacement parts table (Section IIB) for a complete list of Federal Signal lamps that are available. Install a new flash tube by fully seating it into the socket.
5. Reassemble the unit.
6. Test light for proper operation.

B. Replacement Parts.

Description	Part No.
Plastic Dome Assembly, Amber	K8459125A
Plastic Dome Assembly, Blue	K8459125A-01
Plastic Dome Assembly, Clear	K8459125A-02
Plastic Dome Assembly, Green	K8459125A-03
Plastic Dome Assembly, Red	K8459125A-04
Fresnel lens, Clear	K8422B428A
Dome ring gasket	K8459123A
Surface mount gasket	K8459127A
Flash Tube	K8107178A
Printed circuit board assy., 12-24VDC	K2001265D-01
Printed circuit board assy., 120VAC	K200865G-02
Printed circuit board assy., 240VAC	K200865G-03

C. Accessories.

Description	Part No.
Mounting Bracket, Surface	371BRCKT
Conduit hub kit, 3/4" N.P.T.	8459138A
Close-up plug, 1" N.P.T.	8459130A

III. SERVICE

The Federal factory will service your equipment or provide technical assistance with any problems that cannot be handled locally.

Any units returned to Federal Signal for service, inspection, or repair must be accompanied by a Return Material Authorization. This R.M.A. can be obtained from a local Distributor or Manufacturer's Representative.

At this time a brief explanation of the service requested, or the nature of the malfunction, should be provided.

Address all communications and shipments to:

FEDERAL SIGNAL CORPORATION
 Electrical Products Division
 Service Department
 2645 Federal Signal Drive
 University Park, IL 60466-3195

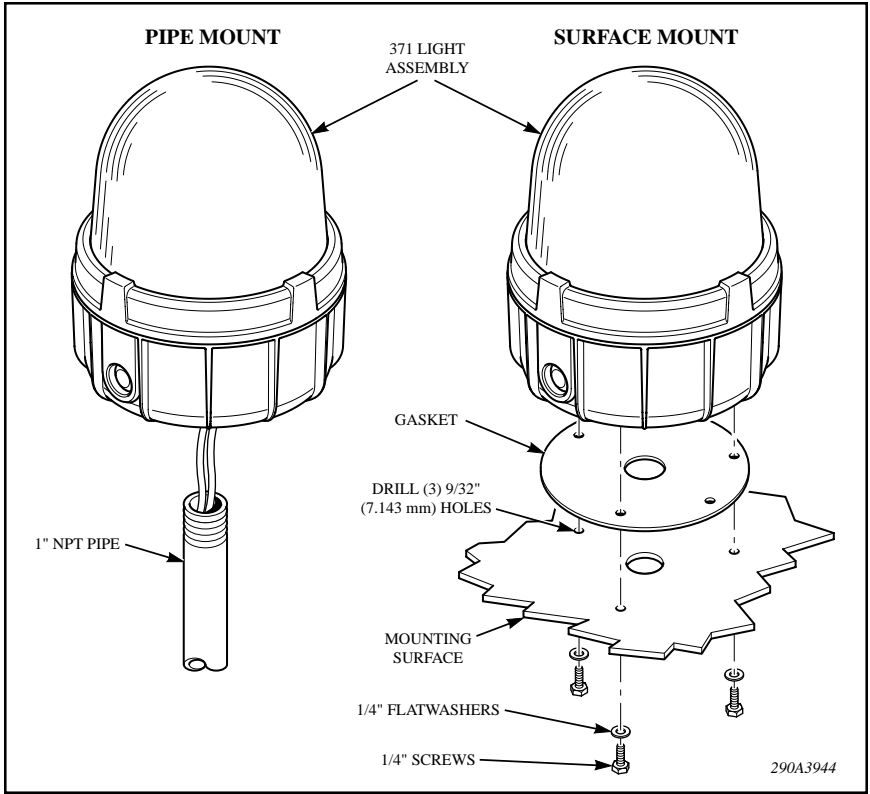

Figure 1.

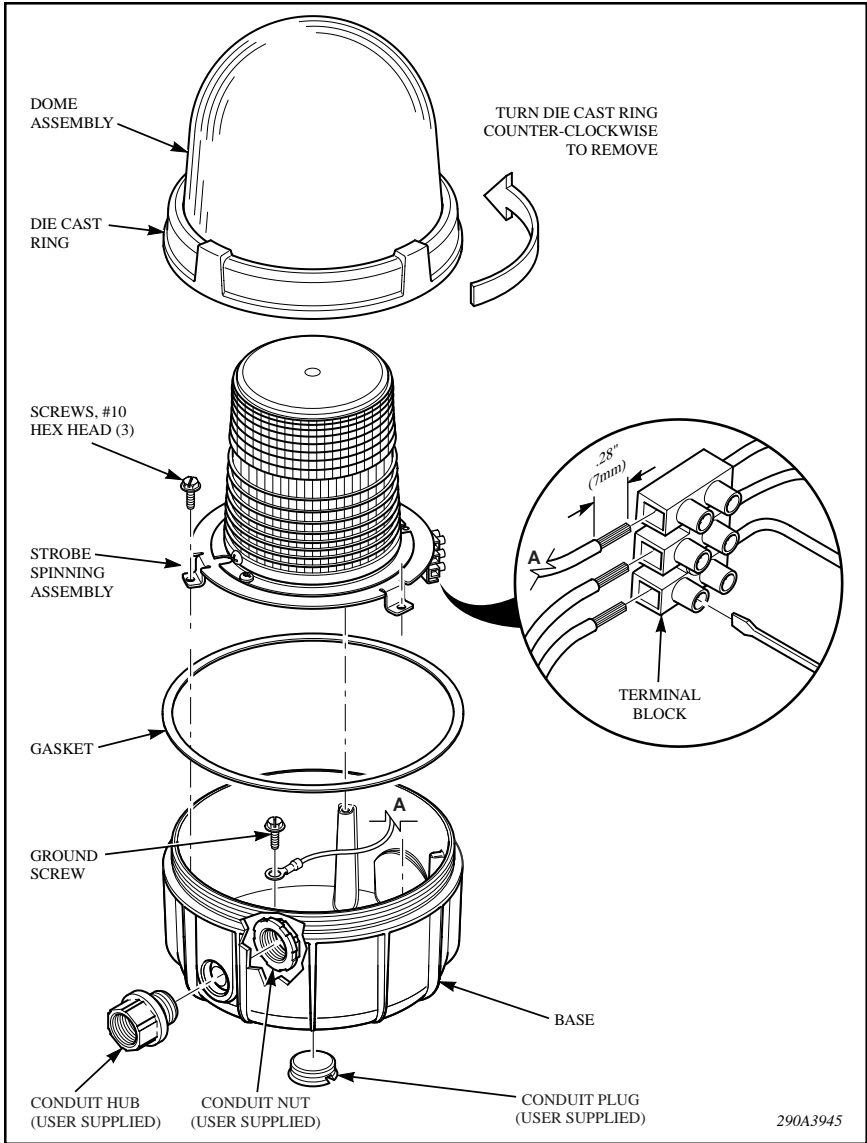

Figure 2.

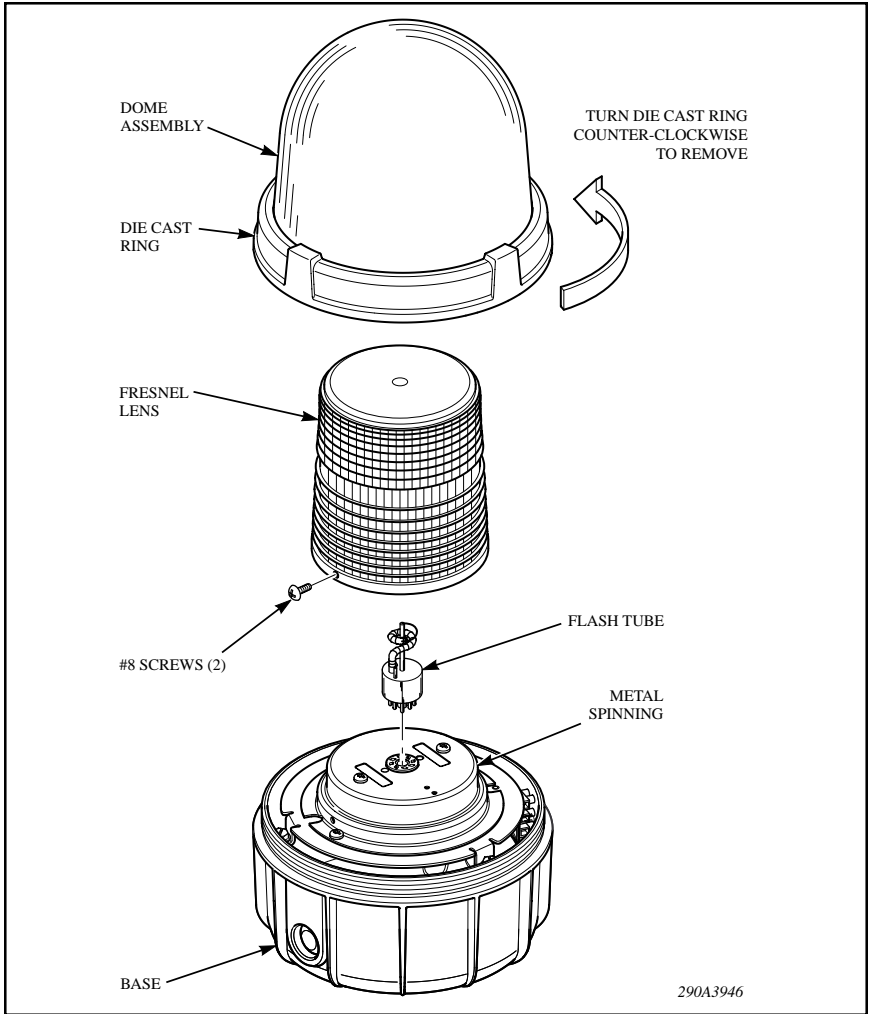

Figure 3.

256A504H
REV. H 300
Printed in USA.