

PRICE \$ 5.00



# MODEL 300MB-SB

## CommCenter

### Series B

## INSTALLATION AND SERVICE INSTRUCTIONS

256A1078E  
REV. E 6/99  
Printed in U.S.A.



PRICE \$ 5.00



# MODEL 300MB-SB

## CommCenter

### Series B

## INSTALLATION AND SERVICE INSTRUCTIONS

256A1078E  
REV. E 6/99  
Printed in U.S.A.



## LIMITED WARRANTY

*The Signal Division, Federal Signal Corporation (Federal), warrants each new product to be free from defects in material and workmanship, under normal use and service, for a period of two years on parts replacement and one year on labor from the date of delivery to the first user-purchaser.*

*During this warranty period, the obligation of Federal is limited to repairing or replacing, as Federal may elect, any part or parts of such product which after examination by Federal discloses to be defective in material and/or workmanship.*

*Federal will provide warranty for any unit which is delivered, transported prepaid, to the Federal factory or designated authorized warranty service center for examination and such examination reveals a defect in material and/or workmanship.*

*This warranty does not cover travel expenses, the cost of specialized equipment for gaining access to the product, or labor charges for removal and re-installation of the product. Lamps, flash tubes, or batteries are not covered under warranty.*

*This warranty does not extend to any unit which has been subjected to abuse, misuse, improper installation or which has been inadequately maintained, nor to units which have problems relating to service or modification at any facility other than the Federal factory or authorized warranty service centers.*

**THERE ARE NO OTHER WARRANTIES, EXPRESSED OR IMPLIED, INCLUDING BUT NOT LIMITED TO, ANY IMPLIED WARRANTIES OF MERCHANTABILITY OR FITNESS FOR A PARTICULAR PURPOSE. IN NO EVENT SHALL FEDERAL BE LIABLE FOR ANY LOSS OF PROFITS OR ANY INDIRECT OR CONSEQUENTIAL DAMAGES ARISING OUT OF ANY SUCH DEFECT IN MATERIAL OR WORKMANSHIP.**



**FEDERAL SIGNAL CORPORATION**

Electrical Products



# TABLE OF CONTENTS

Paragraph		Page
SECTION I - GENERAL DESCRIPTION		
1-1	General .....	1-1
1-2	Chassis Description .....	1-1
SECTION II - SPECIFICATIONS		
2-1	Power Input .....	2-1
2-2	Emergency Power Source Input .....	2-1
2-3	Audio/Cascade Input .....	2-1
2-4	Audio Outputs .....	2-1
2-5	Remote Tone Activation Circuit .....	2-2
2-6	Physical .....	2-2
SECTION III - INSTALLATION		
3-1	Unpacking .....	3-1
3-2	Kit Contents .....	3-1
3-3	Input Configuration .....	3-1
3-4	Control Circuitry .....	3-1
3-5	Power .....	3-2
3-6	Audio Input .....	3-2
3-7	Signal Lines .....	3-3
3-8	Model 300MB Signal Connections .....	3-3
3-9	Connection to Remote Devices .....	3-3
3-10	300MB Power Connections .....	3-4
3-11	Typical Installations .....	3-4
3-12	Storage Chip Installation .....	3-7
SECTION IV - SERVICE		
4-1	General .....	4-1
4-2	Replacement Parts .....	4-1



# SECTION I GENERAL DESCRIPTION

## 1-1. GENERAL.

The CommCenter, Model 300MB Series B (figure 1-1), is a digital playback device that is capable of generating up to six different prerecorded voice messages, melodies, tones and/or signals. This central control device interfaces with any decentralized or centrally amplified system. The CommCenter can control signal lines to Federal Signal SelecTone® Models 300GC, 300GCX, 300X, 302GC, 302GCX, 302X, and 50GC speaker/amplifiers. It can also interface with any SelecTone Control Unit, Models 300VSC-1 or 300SCW-1. It can directly drive speakers designed for 25Vrms line operation. It can also provide a 1Vp-p audio signal, and can be used as a remote audio input for a public address sound system. Using the 300MB's cascading function, CommCenters can be linked together to provide a system with the capability of more than six messages.

### NOTE

The Series B CommCenter uses a different message storage chip than the Series A. These chips cannot be interchanged between Series A and Series B models. Make sure to specify which series CommCenter you have before ordering any additional messages.

The CommCenter is intended to be installed in indoor (NEMA 1) or other protected installations only. It can be mounted on any horizontal or vertical surface using #10 screws, appropriate for the type of mounting surface material, and the four mounting holes in the 300MB's housing (see figure 1-2).

The CommCenter can be used for a variety of prioritized signaling purposes, such as indicating the status of a machine or process, background messages, evacuation, alarm, start and dismissal, and other audible notification

applications. The system can be automated if external (customer-supplied) devices such as programmable controllers, heat detectors, switches or program clocks are connected to the remote inputs. This product is not listed for fire use.

A CommCenter plays and amplifies messages through signal lines to the remote SelecTone devices in the system. To connect the SelecTone speaker/amplifier to the signal line, a Model 300CK Connector Kit is required in each SelecTone device. Speakers designed for 25 volt operation can connect directly to the 25 volt output.

Each message can be activated by a contact closure or opening at its associated remote control input. The remote control inputs can be configured to work with either latching or momentary contacts.

## 1-2. CHASSIS DESCRIPTION.

The CommCenter is assembled in a black, powder-coated steel, 2-piece housing. The cover is attached to the housing with four screws, two along each long edge of the enclosure. The rear of the housing incorporates two field wiring compartments baffled off from the printed circuit board area. One compartment is for the connection of the Class II power and signal lines, and the other is for the connection of the Class I power lines. These areas are provided with knock-outs to allow the external wiring to enter the unit through appropriate installer-supplied bushings.

Each CommCenter can accommodate up to six storage chips, selected from a library of prerecorded voice messages, melodies, tones and/or signals. There is one message per storage chip. Each chip plugs into a 28-pin IC socket. The six sockets are labeled Priority Tone 1 through Priority Tone 6 (see figure 1-3).

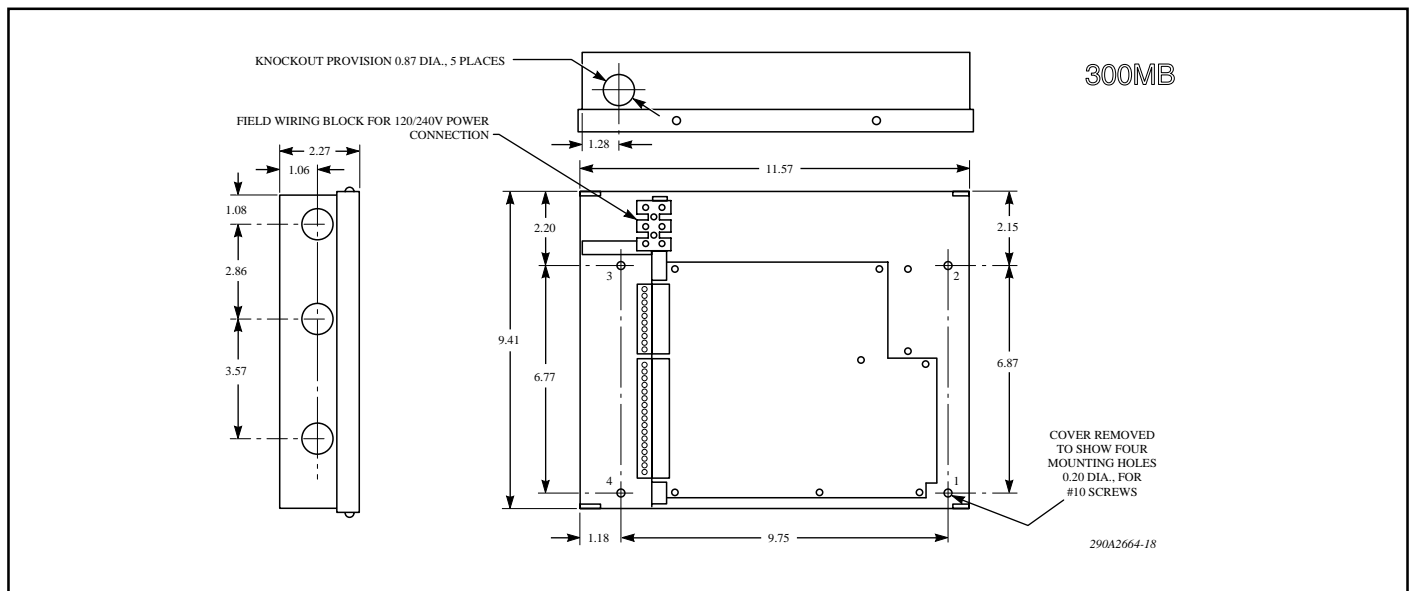
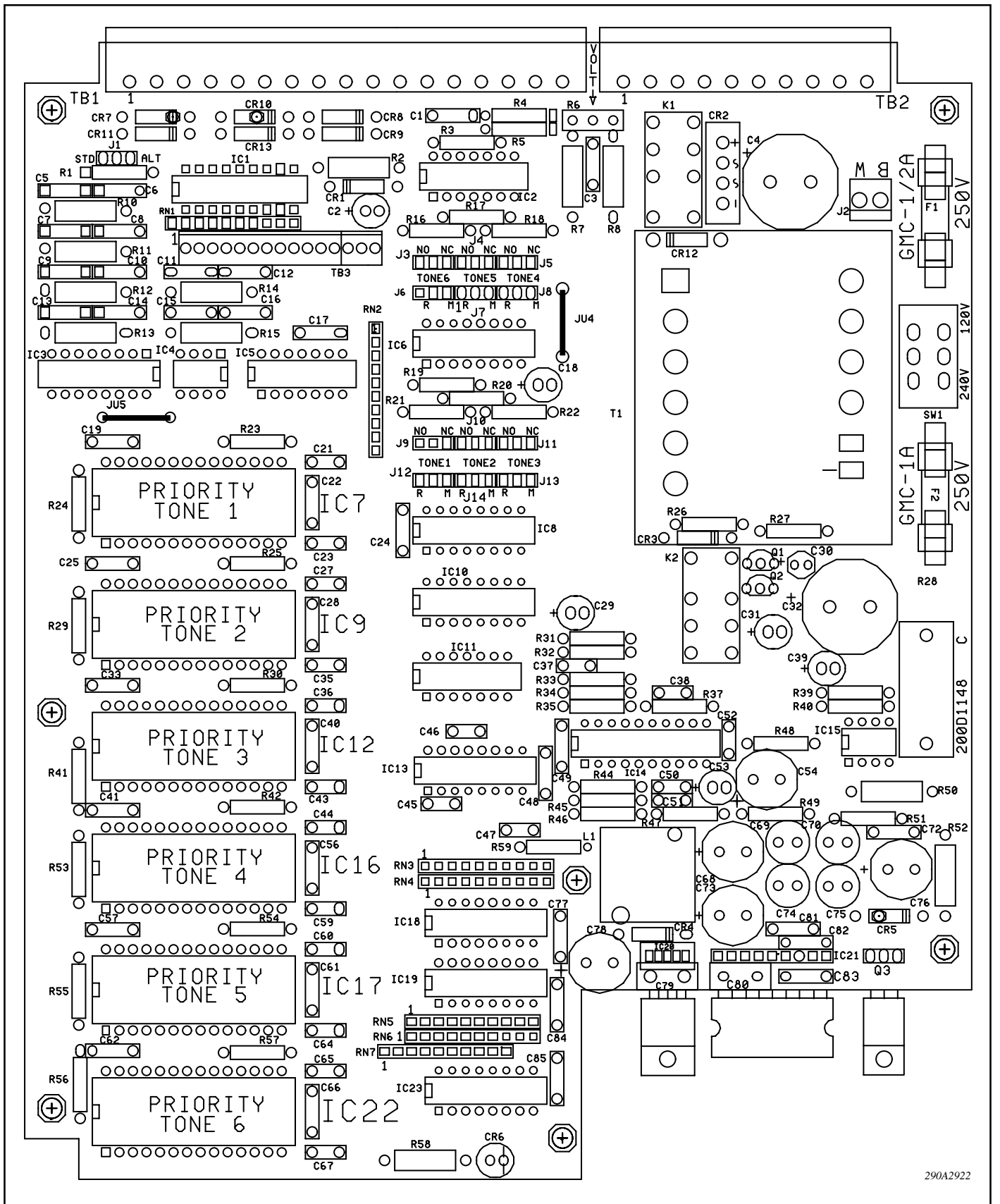

Figure 1-2. Mounting Holes and Dimensions.



290A2922

Figure 1-3. Model 300MB Series B Mother Board.

# SECTION II SPECIFICATIONS

## 2-1. POWER INPUT.

A. Input Voltage .....	120/240V, 50/60HZ
B. Standby Current .....	50Ma 120VAC
C. Operating Current .....	210Ma (MAX)
D. Power Consumption.....	26 Watts (MAX)

## 2-2. EMERGENCY POWER SOURCE INPUT.

A. Input Voltage .....	22-32 VDC
B. Standby Current .....	90Ma
C. Operating Current .....	760Ma

## 2-3. AUDIO/CASCADE INPUT.

Cascade Input	
Input Impedance .....	5k Ohms
Input Voltage.....	1V p-p (MAX)

## 2-4. AUDIO OUTPUTS.

A. Output Impedance	
Unbalanced Sig. line .....	25 Ohms (MAX)
Unbalanced Sig. Line Standby .....	120 Ohms
Balanced Sig Line .....	40 Ohms (MAX)
Low Level Sig. Out .....	600 Ohms
B. Output Voltage Levels No Load (<3% THD)	
Unbalanced Sig. Line .....	9Vrms
Balanced Sig. Line .....	17Vrms
Low Level Sig. Out .....	1Vp-p
C. Output Voltage Levels Max Load (<3% THD)	
Unbalanced Sig. Line .....	8Vrms(25 Ohm load)
Balanced Sig. Line .....	15Vrms(40 Ohm load)
Low Level Sig. Line .....	1Vp-p (600 Ohm load)
D. Tone Output Levels No Load (sq. wave)	
Unbalanced Sig. Line .....	12Vrms
Balanced Sig. Line .....	25Vrms
Low Level Sig. Line .....	1Vp-p
E. Tone Output Levels Max Load (sq. wave)	
Unbalanced Sig. Line .....	12Vrms (25 Ohm load)
Balanced Sig. Line .....	20Vrms (40 Ohm load)
Low Level Sig. Line .....	0.56Vrms (600 Ohm load)
F. Audio Frequency Response Balanced Sig. Line	
40 Ohms max load, From 250Hz to 80KHz	
(Reference 1KHz) .....	-3db
40 Ohm max load, From 450Hz to 60KHz	
(Reference 1KHz) .....	-1db
No load, From 100Hz to 90KHz	
(Reference 1KHz) .....	-3db
No load, From 200Hz to 60KHz	
(Reference 1KHz) .....	-1db
G. Signal To Noise Ratio (<3% THD)	
Chip Input .....	67dbA
H. Audio Distortion From Cascade Input to Balanced Sig.	
Line Output (40 Ohm load) .....	.2%

**2-5. REMOTE TONE ACTIVATION CIRCUIT.**

Message can be initiated by connecting the initiating line to CommCenter Ground by means of a dry contact or open collector.

**2-6. PHYSICAL.**

Weight .....	Shipping	6-5/8 lb. (3.01 kg.)
	Net	5-1/2 lbs. (2.49 kg.)
Dimensions (HWD) .....	2.28" x 9.41" x 11.57"	
Operating Temperature .....	32°F (0°C) to 120°F (49°C)	

# SECTION III INSTALLATION

## WARNING

Failure to follow all safety precautions and instructions may result in property damage, serious injury, or death to you or others.

## SAFETY MESSAGE TO INSTALLERS

Peoples lives depend on your safe installation of our products. It is important to follow all instructions shipped with the products. This device is to be installed by a trained electrician who is thoroughly familiar with the National Electric Code and will follow the NEC guidelines as well as local codes.

The selection of the mounting location for the device, its controls and the routing of the wiring is to be accomplished under the direction of the Facilities Engineer and the Safety Engineer. In addition, listed below are some other important safety instructions and precautions you should follow:

- Although your signaling system is working properly, it may not be completely effective. People may not hear or heed your warning signal. You must reconize this fact and proceed with due caution.
- Read and understand all instructions before installing or operating this equipment.
- Do not connect or service this unit when power is on.
- Optimum sound distribution will be severely reduced if any objects are in front of the speaker. You should ensure that the front of the speaker is clear of any obstructions.
- All effective warning speakers produce loud sounds which may cause, in certain situations, permanent hearing loss. You should take appropriate precautions such as wearing hearing protection.
- All effective warning speakers produce loud sounds, which may cause, in certain situations, permanent hearing loss. The device should be installed far enough away from potential listeners to limit their exposure while still maintaining its effectiveness. The OSHA Code of Federal Regulations 1910.95 Noise Standard provides guidelines which may be used regarding permissible noise exposure levels.
- After installation, test the sound system to ensure proper operation.
- Show these instructions to your Safety Engineer and all operating personnel and then file them in a safe place and refer to them when maintaining and/or reinstalling the unit.
- Establish a procedure to routinely check the sound system for proper activation and operation.

## 3-1. UNPACKING.

After unpacking the Model 300MB, examine it for damage that may have occurred in transit. If the equipment has been damaged, do not attempt to install or operate it, file a claim immediately with the carrier stating the extent of the damage. Carefully check all envelopes, shipping labels and tags before removing or destroying them. Before attempting to install the CommCenter, be sure that all parts listed in the KIT CONTENTS LIST have been supplied.

## 3-2. KIT CONTENTS.

Qty.	Description	Part No.
1	Plug, 10 Position	140A332-10
1	Plug, 17 Position	140A332-17

## 3-3. INPUT CONFIGURATION.

The CommCenter can be configured for remote activation in four ways:

- Normally open latching contacts.
- Normally open momentary contacts.
- Normally closed latching contacts.
- Normally closed momentary contacts.

The unit is factory set to be activated by closing a normally open latching contact between the associated input and circuit ground. When activated the message will continue to loop and repeat. It will stop as soon as it is deactivated. When configured for momentary activation, the message will continue to loop and repeat until the input is deactivated. Upon deactivation of the input, it will play the entire message before stopping.

Each of the six inputs can be individually configured by moving a two position jumper on a three position header. See table 3-1 for a list of the Priority Tones, their associated jumper designation and their marking as shown on the printed circuit board silkscreen.

## 3-4. CONTROL CIRCUITRY.

A. The control circuitry in the CommCenter has a built-in priority level feature. If a given message is already sounding when a higher priority message is activated, the higher priority message automatically overrides the lower priority message. When the higher priority message is deactivated, the lower priority message is initiated as long as it is still activated. The messages are prioritized with Priority Tone 1 having the highest priority down to Priority Tone 6. The cascade input has the lowest level of priority.

MESSAGE	Jumper	Marking	Jumper	Marking
PRIORITY TONE 1	J9	NO NC	J12	R M
PRIORITY TONE 2	J10	NO NC	J14	R M
PRIORITY TONE 3	J11	NO NC	J13	R M
PRIORITY TONE 4	J5	NO NC	J8	R M
PRIORITY TONE 5	J4	NO NC	J7	R M
PRIORITY TONE 6	J3	NO NC	J6	R M

Notes: 1. NO NC configures an individual channel to interface to normally open (NO) or normally closed (NC) contacts.

2. R M configures an individual channel to interface to a latched contact (R) or a momentary contact (M).

Table 3-1.

B. A message can be activated from the tone activation inputs on TB1. A dry contact, either normally open or normally closed depending on the configuration, connected between the associated message (TB1-1 through TB1-6) and COM (TB1-7) will activate a tone. The configuration of these channels is described in paragraph 3-3. These inputs are opto coupled to reduce the possibility of noise on the signal lines falsely activating a message.

C. There are two sets of contacts which can be used to monitor the status of a CommCenter. When power is applied, a relay with form C contacts is activated. These contacts are connected to TB2 and are labeled Power Monitor Relay. The second set of contacts monitor activation of any of the six messages or a cascaded input. These contacts are labeled Push To Talk (PTT) on TB1.

D. There is a power down pin which, when grounded, disables the power relay and removes power from the rest of the system. The power down mode can only be used when a CommCenter is powered by 24VDC. The Commcenter is factory set with the power down pin disabled.

**WARNING**

Do not perform any installation or maintenance to the system when power is on.

To configure the unit to work in the power down mode, move jumper J1 on the printed circuit board inside the housing from STD to ALT. After

moving the jumper, the unit can be powered only by 24VDC when the power down pin is grounded.

**3-5. POWER.**

In order to prevent power to a CommCenter from being turned off accidentally, the unit does not have a power switch. A 300MB can be operated on either 120VAC, 50/60 HZ or 24VDC input power.

**WARNING**

Failure to follow all safety precautions and instructions may result in property damage serious injury, or death to you or others.

Do not perform any installation or maintenance on this system when power is on.

This device is to be installed by a trained electrician who is thoroughly familiar with the National Electrical Code and will follow the NEC guidelines as well as local codes.

**CAUTION**

The selection of the mounting location for this device, its controls, power supplied, and the routing of the wiring is to be accomplished under the direction of the facilities engineer and the safety engineer.

If operation on 120VAC is desired, 120VAC is input through the 3-position field wiring terminal block located at the back of the unit. Two knock-out openings are provided. One knock-out should be removed and provided with a bushing through which the power lines can be routed into the field wiring compartment. The 300MB is factory set for 120VAC operation. If operation on 240VAC is desired, switch SW1 must be set to the 240V position.

If operation on 24VDC is desired, 24VDC is input on the two terminals shown in figure 3-1. Remove the labeled jumper from terminals TB2-7 and TB2-8 of terminal block TB2, before using these positions. If 24VDC operation is chosen, a Class II power supply and its associated wiring should be installed. Refer to paragraph 3-4.D. if the power down option is desired.

**3-6. AUDIO INPUT.**

There is a provision for a low level, low impedance audio signal input at the rear of the unit. It has been designed to accept a cascaded input from a slave CommCenter, TB2-1, but it could be audio from a telephone system, radio receiver, CD player, or tape player. When the enable pin on the cascade input is pulled to circuit ground, TB2-2, audio on the cascade in signal line is gated through the CommCenter and output on the signal lines. As stated before, this input is the lowest priority. The audio level input should be 1Vp-p. When cascading units, connect the slave unit's enable signal out terminals to the master unit's enable and signal in terminals. The SIG COM

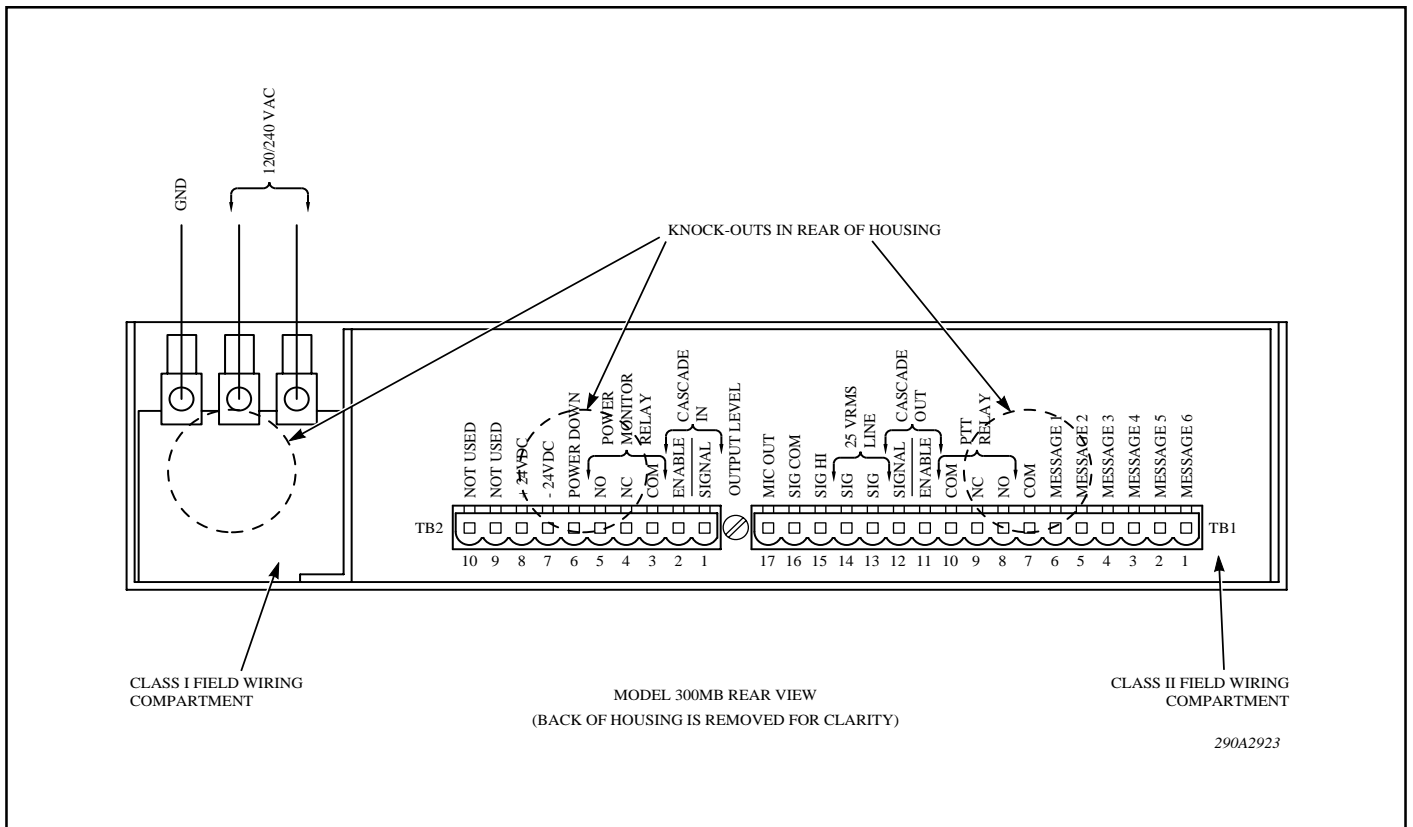

Figure 3-1. Model 300MB Rear View.

terminals (TB1-16) of both units also need to be connected together as shown in figure 3-2.

charges as opposed to a one-time cost of performing the installation.

### 3-7. SIGNAL LINES.

The signal lines transfer the messages from a CommCenter to the remote SelecTone devices. In order to reduce the possibility of cross talk, hum, and static noise pick-up, the signal lines must be twisted pair audio cable. In the majority of systems, use AWG 18 twisted pair audio cables. Shielded, twisted pair cable is recommended when the Class II signal circuit is in the vicinity of welding equipment, carbon arc equipment, or similar electrical devices. Never use a cable having wire smaller than AWG 22.

#### CAUTION

Federal Signal Corporation does not recommend that new or existing telephone lines be used as signal lines in a SelecTone system for the following reasons:

1. Interference from other services or systems, or interference from the system to other services.
2. Cross talk, interference, or hum induced by other telephone lines.
3. Extended downtime because of the second party involvement required to service the lines.
4. The additional cost of installation, interfacing devices and monthly

### 3-8. MODEL 300MB SIGNAL CONNECTIONS.

#### CAUTION

Mixing signal lines with power lines could cause electrical interference, which could impede or render the system inoperable. Do not install signal lines in the same conduit with power lines.

To connect the signal lines of the SelecTone system to the 300MB, connect a color coded twisted pair of audio cables having conductors no smaller than 18 AWG to SIG HI (TB1-15) and SIG COM (TB1-16) terminals on TB1 (see figure 3-1). Every remote SelecTone signaling device in the system will be connected in parallel to these lines. When connecting the remote devices in parallel to the signal lines, observe the correct polarity and install wire nuts over the connections. The yellow wires on the 300CK should be connected to the SIG HI while the blue wires should be connected to SIG COM.

The 25Vrms speaker output is available at TB1-13 and TB1-14 for direct connection to ceiling speakers (see figure 3-1). Remove the labeled jumper from terminals TB1-13 and TB1-14 of terminal block TB1, before using these positions. Signal line losses need to be considered when calculating how many speakers can be connected to the 300MB.

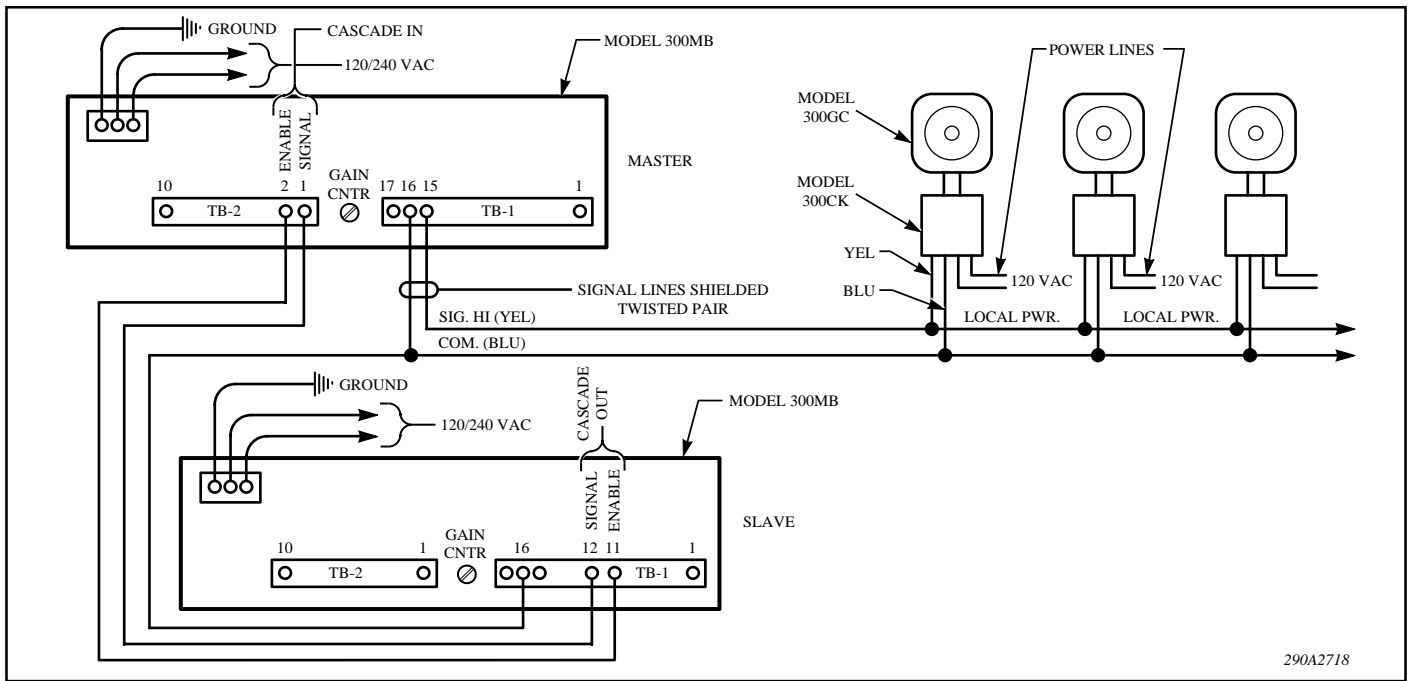

Figure 3-2. Cascading Multiple Units.

### 3-9. CONNECTION TO REMOTE DEVICES.

Physically install the remote SelecTone device(s). Follow the installation instructions packed with the device.

- A. 300GC, 300GCX, 300X, 302GC, 302GCX, 302X and 50GC.

A 300CK Printed Circuit Connector Board is required to connect a 300GC, 300GCX, 300X, 302GC, 302GCX, 302X or 50GC to the signal lines. The 300CK properly terminates the signal lines to the amplifier in the 300GC, 300GCX, 300X, 302GC, 302GCX, 302X and 50GC. As shown in figure 3-3, connect the blue wire on the 300CK to the COM. wire from the 300MB. Connect the yellow wire on the 300CK to the SIG. HI wire from the 300MB.

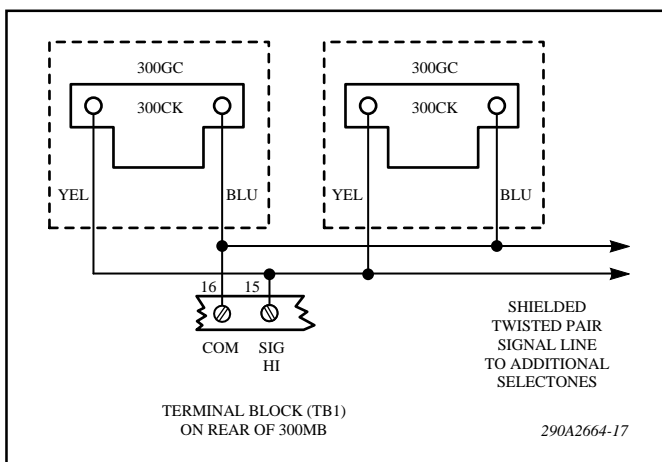

Figure 3-3. 300CK Connections.

### B. 25 Vrms Signal Line Application.

The CommCenter has provision for connecting 25 Vrms line operated speakers to its output. Connect the 25 Vrms line at terminals TB1-13 and TB1-14 of terminal block TB1. Remove the labeled jumper from terminals TB1-13 and TB1-14 of terminal block TB1. Connect the speakers in parallel to this line using 25 Vrms line tap. This output is to be used only if there are no SelecTone system devices connected across TB1-15 and TB1-16. This output is not switched like SelecTone system output across terminals TB1-15 and TB1-16.

### C. Low Level Audio Output.

The 300MB also has a 1 volt peak-to-peak audio output that can be connected to the audio input of another amplifier. This low level output is available across terminals TB1-16 and TB1-17 and is labeled as MIC OUT. It can also be connected to an analog fiber optic transmitter, allowing audio to be transmitted over a fiber optic link in an electrically noisy environment.

### 3-10. 300MB POWER CONNECTIONS.

#### CAUTION

Mixing signal lines with power lines could cause electrical interference, which could impede or render the system inoperable. Do not install power lines in the same conduit as signal lines.

Operating power is connected to the 300MB through the 3-position field wiring terminal block

located at the back of the unit. Two knock-out openings are provided. One knock-out should be removed and provided with a bushing through which the power lines can be routed into the field wiring compartment.

If it is desired to use 24 VDC either as a primary or auxiliary source of power, remove the labeled jumper from terminals TB2-8 and TB2-7 of terminal block TB2. Connect the "+" terminal of 24 volt DC power supply to the terminal TB2-8 (+24 VDC) and "-" terminal of the 24 VDC power supply to the terminal TB2-7 of the TB2 terminal block located in the back of the 300MB (see figure 3-4).

### 3-11. TYPICAL INSTALLATIONS.

#### A. *SelecTone Installation (see figure 3-5).*

In this installation, the CommCenter is acting as a Selectone Control Center driving a 10Vrms signal line. Remote Speaker/Amplifiers have the signal coupled in through a 300CK.

#### B. *300MB Interface with a 300VSC-1, 300SCW-1, 300SSC (see figure 3-6 and table 3-2).*

In this installation the CommCenter is acting as a remote microphone audio input and adds message playback capability to a Selectone system. The gain adjustment on the 300MB needs to be adjusted such that the audio output is at the required

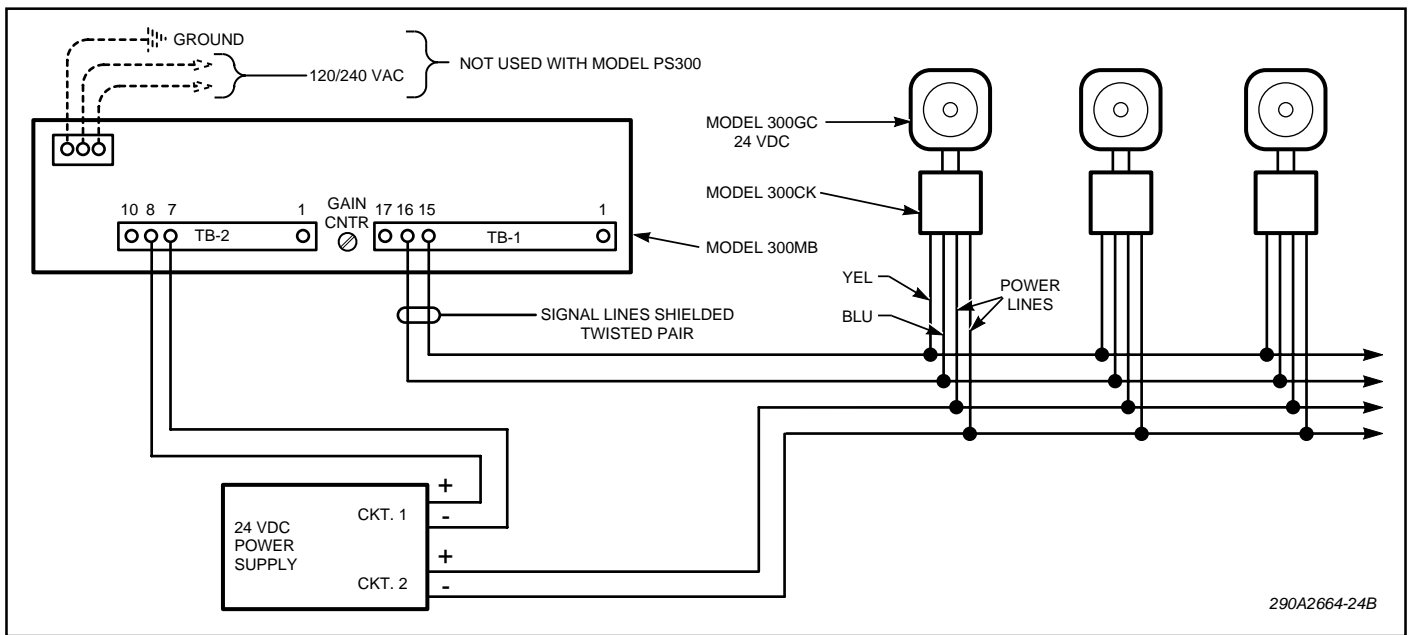

Figure 3-4. Typical Central Power System.

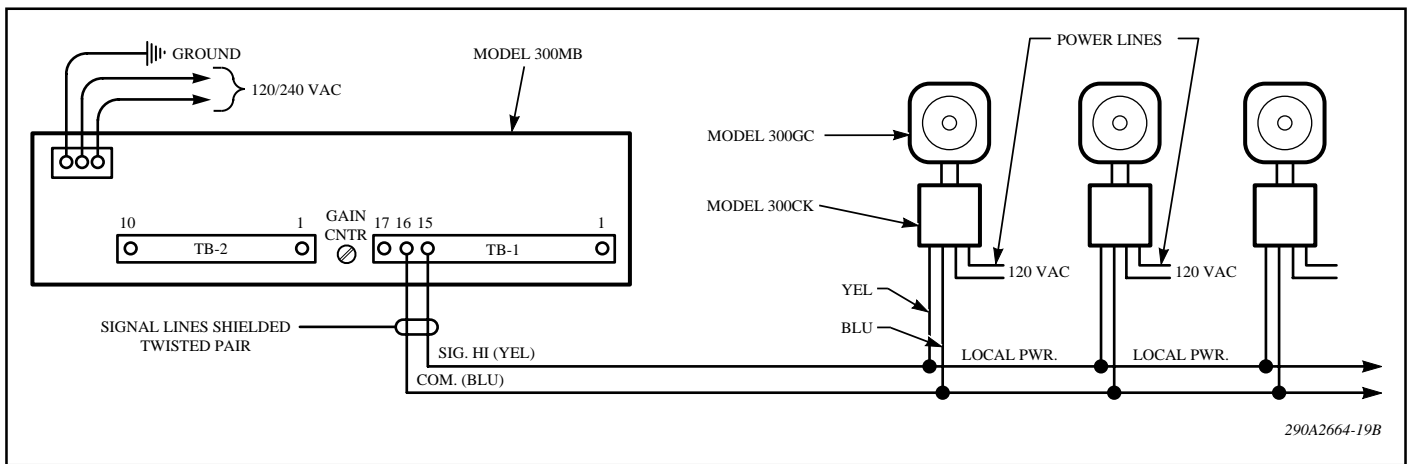

Figure 3-5. Typical Selectone Installation.

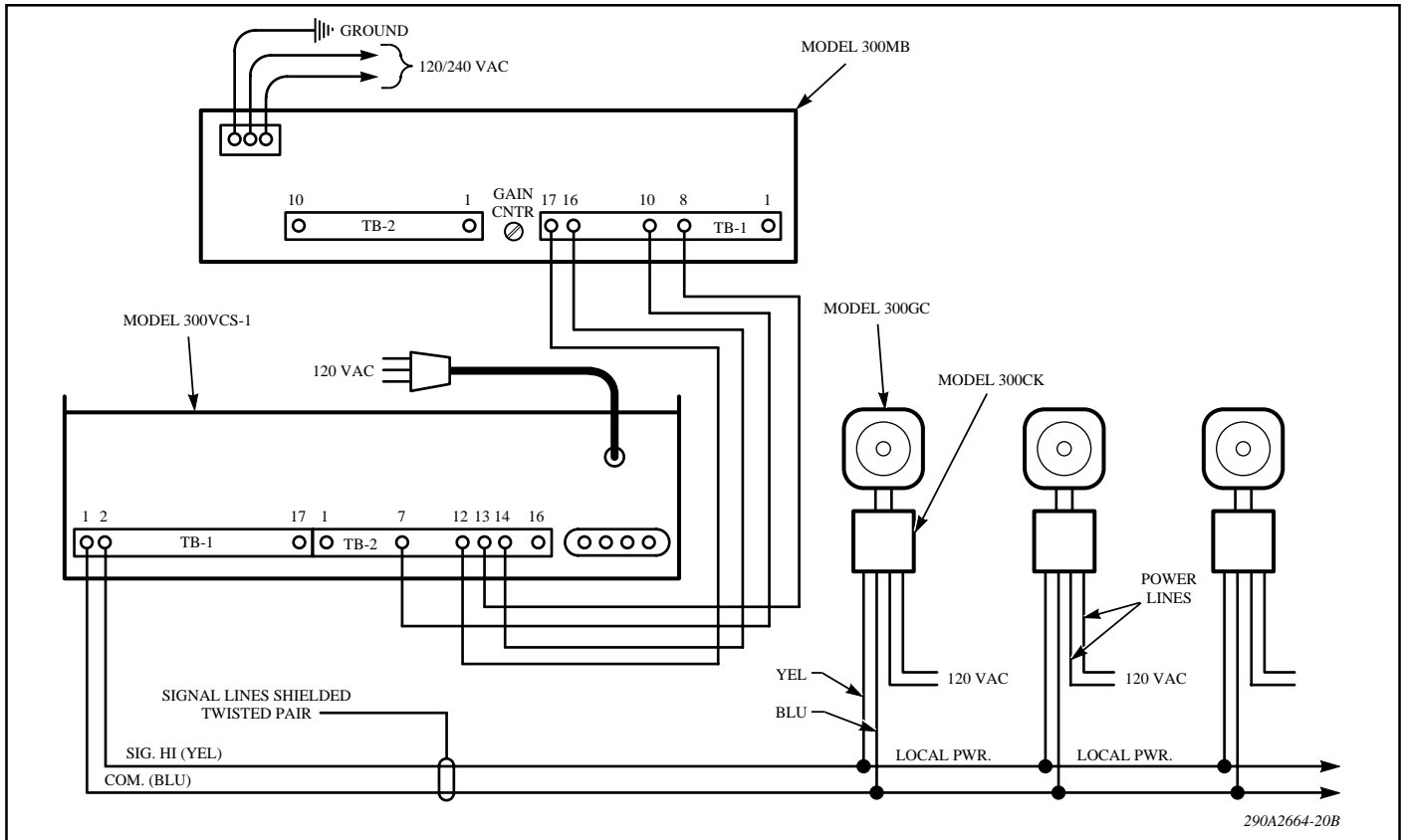

Figure 3-6. Models 300MB and 300VSC-1.

300MB		300VSC-1/300SCW-1		300SSC	
TB1-8	PTT-NO	TB2-13	PTT	TB201-9	PTT
TB1-10	PTT-COM	TB2-7	GND	TB201-8	COM
TB1-16	SIG COM	TB2-14	MIC COM	TB201-8	COM
TB1-17	MIC OUT	TB2-12	MIC AUDIO IN	TB201-7	AUDIO

Table 3-2. 300MC Connections to 300VSC-1, 300SCW-1, or 300SSC.

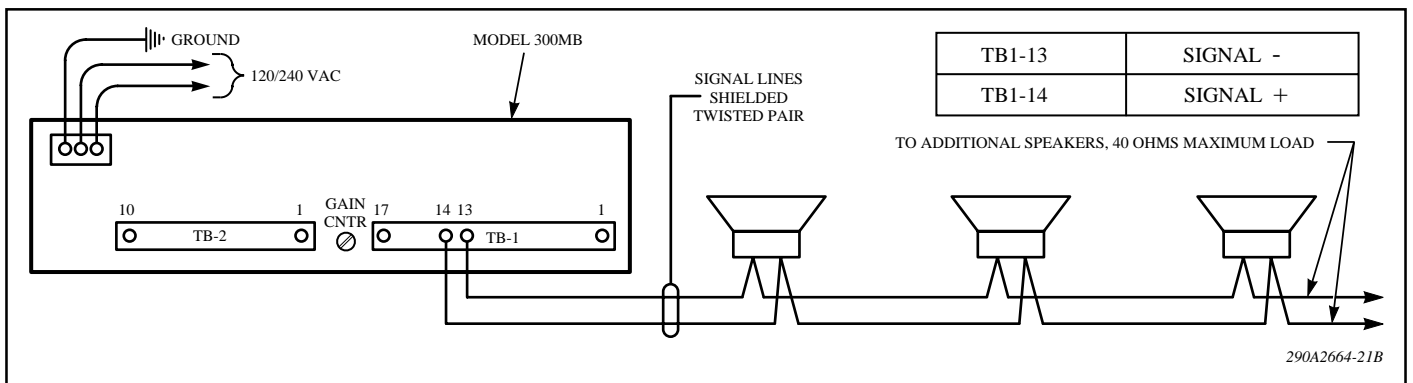

Figure 3-7. Model 300MB with 25VRMS Connections.

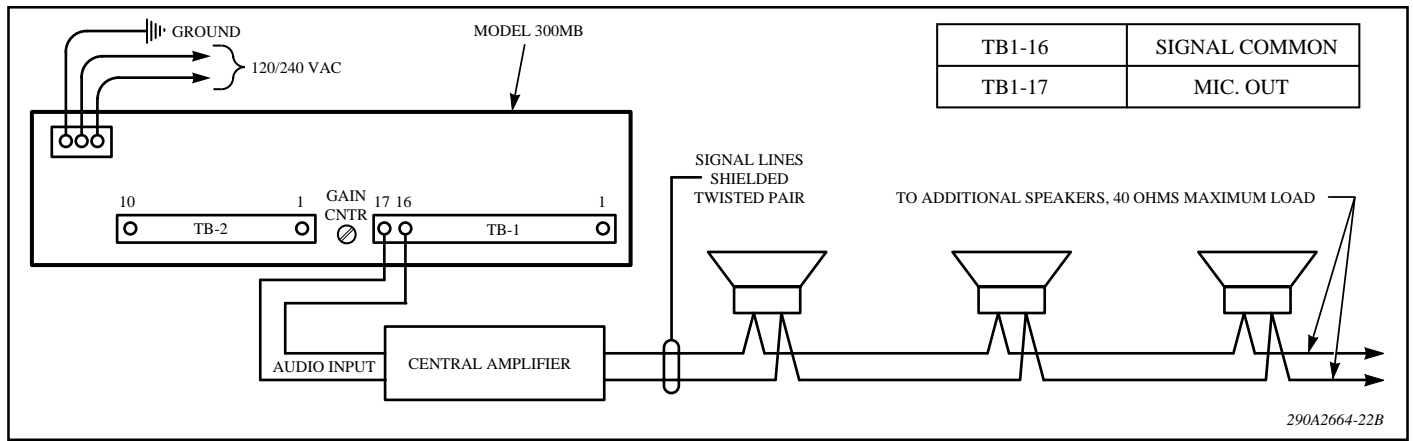

Figure 3-8. Model 300MB with Central Amplifier Connections.

remote mic audio input level (16mVrms MAX.) for the 300VSC-1. Failure to adjust this level will cause distortion and clipping in the system.

C. *300MB Driving a 25Vrms Speaker Line (see figure 3-7).*

In this installation the CommCenter is directly driving a speaker or speakers, the total power consumed not exceeding the drive capability of a CommCenter.

D. *300MB Interfacing with a Central Amplified System (see figure 3-8).*

In this installation the CommCenter is acting as an audio input to a Central Amplifier. Message playback can be added to an existing Centrally Amplified Paging System.

3-12. STORAGE CHIP INSTALLATION.

**NOTE**

The Series B CommCenter uses a different message storage chip than the Series A. These chips cannot be interchanged between Series A and Series B models. Make sure to specify which series CommCenter you have before ordering any additional messages.

It is necessary to perform the procedures in this section ONLY if it is required to change the priority of the storage chips or adding a different message to the unit is required.

The 300MB can accommodate up to six storage chips. The CommCenter should be shipped from the factory with the storage chips installed. Each storage chip is marked with the Model Number and other information.

**WARNING**

Failure to follow all safety precautions and instructions may result in property damage serious injury, or death to you or others.

Do not perform any installation or maintenance on this system when power is on.

This device is to be installed by a trained electrician who is thoroughly familiar with the National Electrical Code and will follow the NEC guidelines as well as local codes.

**NOTE**

The Storage Chips and the CommCenter's circuitry can be destroyed or damaged by static discharge. Observe anti-static procedures when installing or servicing a CommCenter.

Storage Chips should be installed starting at Priority Tone 1 and working downward. If, for example, only four messages are required, have PT1 through PT4 sockets occupied and leave PT5 and PT6 open.

To remove a storage chip gently pry the IC out of its socket. To install the storage chips insert them into the desired IC sockets on the printed circuit board as shown in figure 1-3 Ensure that the notch on the edge of the new storage chip is facing in the same direction as the old one (next to the resistors at the edge of the board) and that all IC pins are properly inserted in the socket—not bent under.

**CAUTION**

Test the CommCenter after any maintenance is performed.



# SECTION IV SERVICE

## 4-1. GENERAL.

The Federal Signal factory will service your equipment or provide assistance with technical problems that cannot be handled satisfactorily locally.

Any units returned to Federal Signal for service, inspection, or repair, must be accompanied by a Return Material Authorization. The R.M.A. can be obtained from the local Distributor or Manufacturer's Representative. At this time a brief explanation of the service requested or the nature of the malfunction should be provided.

Address all communications and shipments to:

Service Department  
Electrical Products  
Federal Signal Corporation  
2645 Federal Signal Drive  
University Park, IL 60466-3195  
708-534-3400

## NOTE

The Series B CommCenter uses a different message storage chip than the Series A. These chips cannot be interchanged between Series A and Series B models. Make sure to specify which series CommCenter you have before ordering any additional messages.

## 4-2. REPLACEMENT PARTS.

<i>Description</i>	<i>Part Number</i>
Mother Board	K200D1148C
Fuse F1 250V, 1/2 AMP GMC-1/2A	K148A155A
Fuse F2 250V, 1 AMP GMC-1A	K148A155A-01
TB1, 17 Position Terminal Block	K140A332A-17
TB2, 10 Position Terminal Block	K140A332A-10

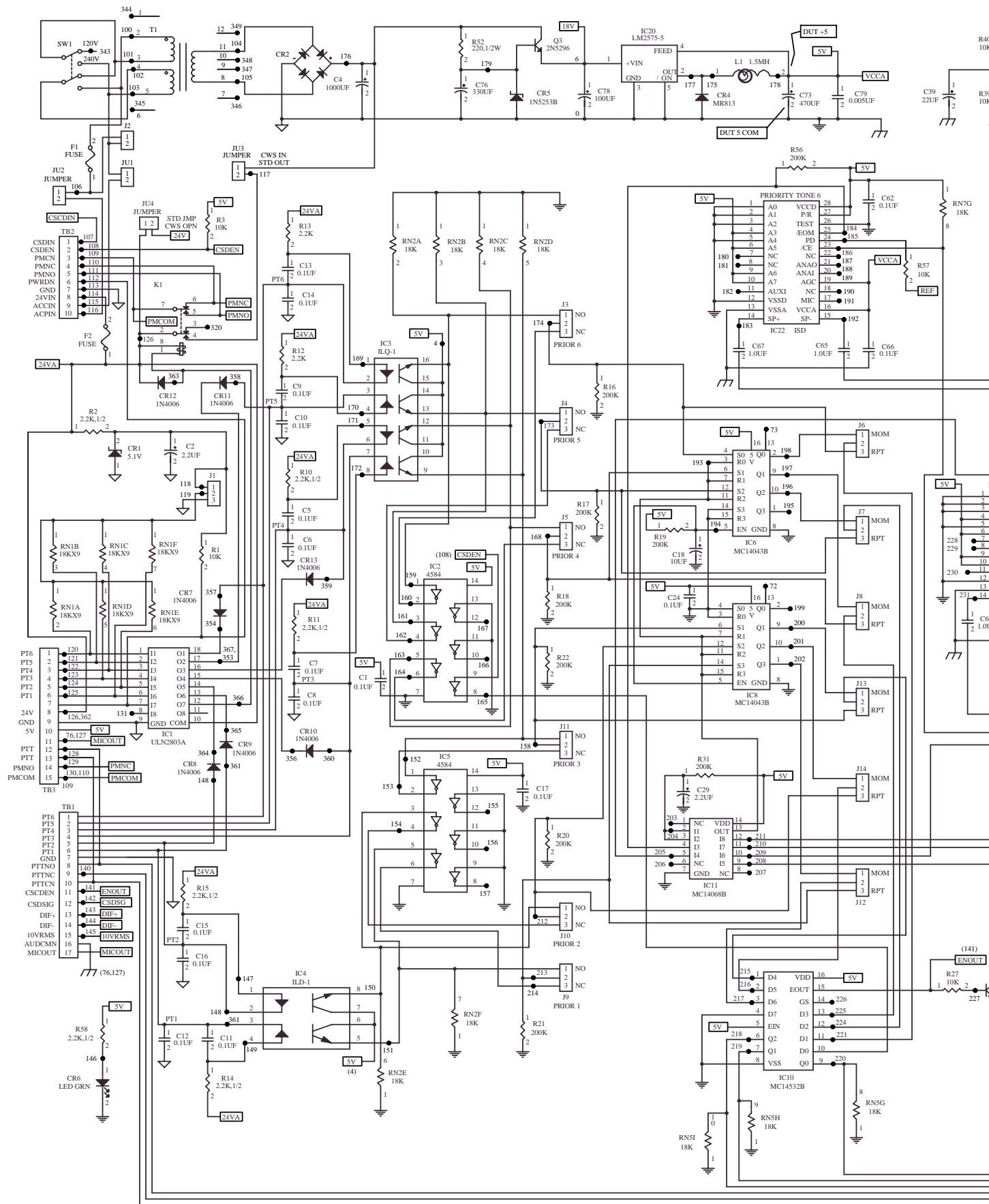

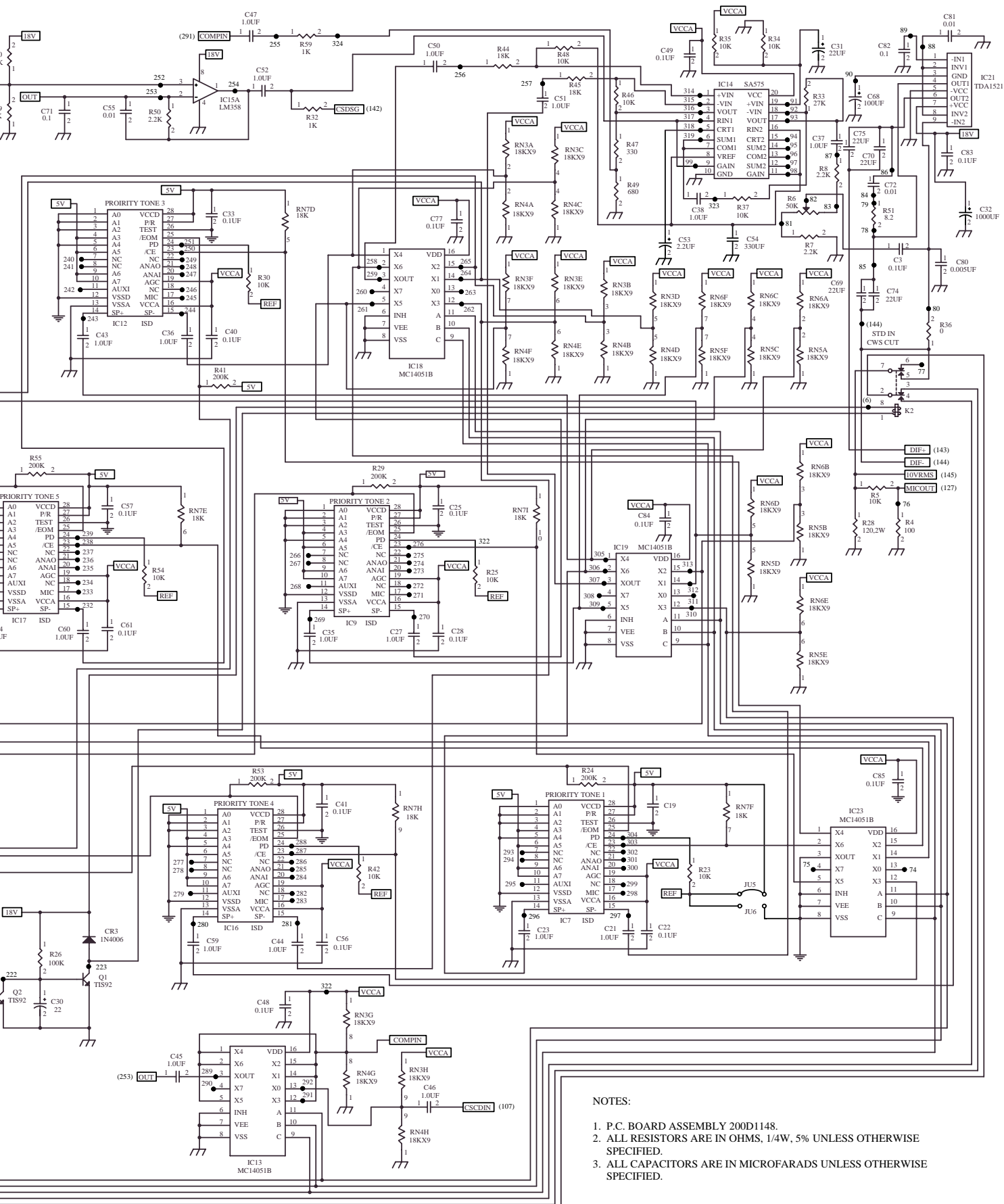

290A291

Figure 4-1. Model 300MB Schematic Diagram.

