

# MODEL WV450X

## INSTALLATION AND SERVICE INSTRUCTIONS FOR MODEL WV450X FOR USE IN HAZARDOUS AND MARINE LOCATIONS

### WV450XD (Flameproof)

ATEX C $\epsilon$ <sub>0539</sub>  II 2 G Exd IIB+ H<sub>2</sub> Tamb -55°C < Ta < +55°C  
IECE $x$  Ex d IIB+H<sub>2</sub> Tamb -20°C < Ta < +55°C

### WV450XD (Increased Safety)

ATEX C $\epsilon$ <sub>0539</sub>  II 2 G Exde IIB+ H<sub>2</sub> Tamb -20°C < Ta < +55°C  
IECE $x$  Ex de IIB+H<sub>2</sub> Tamb -20°C < Ta < +55°C

T-Code @ 110 - 248VAC = T3

T-Code @ 24 - 48VDC = T4

Address all communications and shipments to:



**FEDERAL SIGNAL CORPORATION**  
**Industrial Systems Division**  
2645 Federal Signal Drive  
University Park, IL 60484-3167  
USA

## INSTALLATION AND SERVICE INSTRUCTIONS FOR FEDERAL SIGNAL MODEL WV450X FOR USE IN HAZARDOUS AND MARINE LOCATIONS.

### SAFETY MESSAGE TO INSTALLERS, USERS AND MAINTENANCE PERSONNEL

It is important to follow all instructions shipped with this product. This device is to be installed by a trained electrician who is thoroughly familiar with and will follow all applicable national and local codes in the country of use.

This device should be considered a part of the warning system and not the entire warning system.

The selection of the mounting location for the device, its controls and the routing of the wiring are to be accomplished under the direction of the facilities engineer and the safety engineer. In addition, listed below are some other important safety instructions and precautions you should follow:

- Read and understand all instructions before installing or operating this equipment.
- Never alter the unit in any manner. Safety in hazardous locations may be endangered if additional openings or other alterations are made in units specifically designed for use in these locations.
- Do not connect this light to the system when power is on.
- After installation, ensure that all set screws and threaded joints are properly tightened.
- Keep unit tightly closed when in operation.
- After installation, test the light system to ensure that it is operating properly.
- After testing is complete; provide a copy of this instruction sheet to all personnel.
- Establish a procedure to routinely check the light system for proper activation and operation.

Failure to follow all safety precautions and instructions may result in property damage, serious injury, or death.

#### I. GENERAL.

The Model WV450X Strobe Beacon is a Zone I, flameproof and increased safety visual signaling device listed for hazardous and marine locations. The Model WV450X is available for 24-48 Vdc, 110-120 Vac, 50/60 Hz, and 220-248 Vac, 50/60 Hz. The WV450X can be supplied with outputs of 5, 10, or 15 joules. AC units are also available as 21 joule.

#### II. UNPACKING.



Damaged globes can lead to explosions that could result in serious injury or death.

After unpacking the Model WV450X, examine it for damage that may have occurred in transit. If the equipment has been damaged, do not attempt to install or oper-

ate it, file a claim immediately with the carrier stating the extent of the damage. Carefully check all envelopes, shipping labels and tags before removing or discarding them. Disposal of all shipping materials must be carried out in accordance with national and local codes and standards.

### III. INSTALLATION.

#### NOTE

The glass globe is part of the flameproof housing. The recommended mounting position of this light is in a vertical orientation with the globe facing up. The unit can be mounted in other orientations pending the location of the install.

In all countries, the wiring must comply with all national and local codes and standards.

The Federal Signal WV450X strobe beacon is mounted using a mounting bracket fixed to the base of the unit. Install the fixture on the desired support surface using the three 9.0 mm (0.35 in) mounting holes. Use customer-supplied fasteners suitable for the surface to which the device will be mounted. Refer to Figure 1 for mounting hole locations.



To prevent injury, this apparatus must be securely attached to the floor/wall.

#### A. *General.*

When installing and operating explosion-proof electrical equipment, the relevant national regulations for installation and operation (e.g., EN60079-14 and IEC Wiring Regulations) must be observed.

- Ensure that all nuts, bolts and fixings are secure.
- Painting and surface finishes, other than those applied by Federal Signal Corporation are not permitted.
- Cable termination should be in accordance with specifications applying to the application. Federal Signal recommends that all cables and cores should be fully identified.
- Ensure that only the correct component certified glands are used and that the assembly is shrouded and correctly earthed. Gland entries are M20-1.5 6H. Supply wires to be rated 85 °C minimum.
- Ensure there is not too much slack of cable cores within the unit, due to space limitations.
- Ensure that only the supplied stopping plugs are used to blank off unused gland entry points. Failure to do so may negate the IP rating on the unit.
- This device does not contain over-current protection. The installer should select an appropriate over-current device for the model(s) being used. Reference Table 1 for the appropriate values.

This manual contains standard wiring configurations.

B. *Wiring installation for the WV450XD Flameproof version.*



Do not connect if supply wires are energized.



The DC units are polarity sensitive, and **MAY BE DAMAGED** by incorrect electrical hookup. When connecting the DC strobe unit to the voltage supply lines, **POLARITY MUST BE OBSERVED**. In addition, damage will result if the voltage rating of the particular model is exceeded.

1. Model WV450XD 24-48 Vdc.

**NOTE**

Maximum wire gage is 2.5 mm<sup>2</sup> (12 AWG)

Use wire rated 85 °C or higher.

Ensure only stranded or multiple strand cable is used to terminate the WV450X.

Cable termination should be in accordance with specifications applying to the application. It is recommended that all cables and cores should be fully identified. Use the appropriate cable gland for the application. Gland entry threads are M20-1.5 x 6H.

a. Unscrew the grub screw on the lens cover assembly one full turn (2.0 mm A/F hexagon key required). Remove the cover from the housing by turning the cover counter-clockwise. If the lens cover assembly will not unscrew, back out the grub screw a few additional turns. Once the cover has been removed, slide the PCB out until the terminals clear the case. Wire insulation to be stripped 5 mm to 6 mm (0.22 in). The terminal block uses a spring clamp connection to engage the wire. To disengage the clamp, insert a 2 mm blade tip screwdriver into the small openings near the top. Insert the stripped wire into the larger opening and remove the screwdriver to engage the wire clamp. Connect the positive (+) power source wire to the terminal block screw marked "+". Connect the negative (-) power source wire to the terminal block screw marked "-". Use Figure 2 for reference.

b. After cable termination has been completed, the PCB can be fully inserted into the enclosure. Ensure that the bottom edge of PCB is trapped between the holding pegs in the bottom of the enclosure. Be aware of the correct PCB orientation, as there is only one way the board will fit. The large capacitors should face the largest side of the PCB offset inside the enclosure.

c. To replace the cover, use the same procedure as removing but in reverse manner, ensuring the cover is screwed tightly. Turn the cover clockwise to tighten. There should be a maximum gap of 0.3 mm (0.012 in) between the faces of the enclosure and cover to ensure O-ring compression. Turn the grub screw one full turn or until the screw contacts the housing.

d. Ensure that the unused wire entry is sealed with the provided component certified brass M20-1.5 x 6g stopping plug.

2. Models WV450XD 110 and 220 Vac.

## NOTE

Maximum wire gage is 2.5 mm<sup>2</sup> (12 AWG)

Use wire rated 85 °C or higher.

Ensure only stranded or multiple strand cable is used to terminate the WV450X.

Cable termination should be in accordance with specifications applying to the application. It is recommended that all cables and cores should be fully identified. Use the appropriate cable gland for the application. Gland entry threads are M20-1.5 6H.

a. Unscrew the grub screw on the lens cover assembly one full turn (2.0mm A/F hexagon key required). Remove the cover from the housing by turning the cover counter-clockwise. If the lens cover assembly will not unscrew, back out the grub screw a few additional turns. Once the cover has been removed, slide the PCB out until the terminals clear the case. Wire insulation to be stripped 5 mm to 6 mm (0.22 in). The terminal block uses a spring clamp connection to engage the wire. To disengage the clamp, insert a 2 mm blade tip screwdriver into the small openings near the top. Insert the stripped wire into the larger opening and remove the screwdriver to engage the wire clamp. Connect the line (hot) power source wire to the terminal block clamp marked "L". Connect the neutral (common) power source wire to the terminal block clamp marked "N". Connect the ground wire to the terminal block clamp marked with the ground symbol. Use Figure 2 for reference.

b. After cable termination has been completed, the PCB can be fully inserted into the enclosure. Ensure that the bottom edge of PCB is trapped between the holding pegs in the bottom of the enclosure. Be aware of the correct PCB orientation, as there is only one way the board will fit. The large capacitors should face the largest side of the PCB offset inside the enclosure.

c. To replace the cover, use the same procedure as removing but in reverse manner, ensuring the cover is screwed tightly. Turn the cover clockwise to tighten. There should be a maximum gap of 0.3 mm between the faces of the enclosure and cover to ensure O-ring compression. Turn the grub screw one full turn or until the screw contacts the housing.

d. Ensure that the unused wire entries are sealed with the provided component certified brass M20-1.5 x 6g plug.

C. *Wiring installation for the WV450XE Increased Safety version.*



Do not connect if supply wires are energized.



The DC units are polarity sensitive, and MAY BE DAMAGED by incorrect electrical hookup. When connecting the DC strobe unit to the voltage supply lines, POLARITY MUST BE OBSERVED. In addition, damage will result if the voltage rating of the particular model is exceeded.

The WV450XE terminal block is supplied with 3 poles and 4 conductors per pole. The terminal blocks allows for easy supply in and loop out wiring to string beacons in series. The terminal block uses a spring clamp connection to engage the wire. To disengage the clamp, insert a 2 mm blade tip screwdriver into the small openings closest to the terminal labels as shown in Figure 4. Insert the stripped wire into the larger opening and remove the screwdriver to engage the wire clamp.

1. Model WV450XE 24-48 Vdc.

**NOTE**

Maximum wire gage is 2.5 mm<sup>2</sup> (12 AWG)

Use wire rated 85° C or higher.

Ensure only stranded or multiple strand cable is used to terminate the WV450X.

Cable termination should be in accordance with specifications applying to the application. It is recommended that all cables and cores should be fully identified. Use the appropriate cable gland for the application. Gland entry threads are M20-1.5 6H.

- a. Unscrew the four M4 screws and lift off the terminal box cover. The terminal block is supplied with 3 poles, 4 conductors per pole. The terminal blocks allow for easy supply in and loop out wiring to string beacons in series. Wire insulation to be stripped 8 mm to 9 mm (0.33 in). The terminal block uses a spring clamp connection to engage the wire. To disengage the clamp, insert a 2 mm blade tip screwdriver into the small openings closest to the terminal labels as shown in Figure 4. Insert the stripped wire into the larger opening and remove the screwdriver to engage the wire clamp. Connect the positive (+) power source wire to the terminal block pole marked "L1/+". Connect the negative (-) power source wire to the terminal block pole marked "N/-?". Use Figure 3 for reference. When using more than one single or multiple strand lead, the connection into either side of any terminal must be joined in a suitable manner, e.g., two conductors into a single insulated crimped bootlace ferrule.

**NOTE**

Leads connected to the terminals shall be insulated for the appropriate voltage and this insulation shall extend to within 1 mm of the metal of the terminal throat.

**NOTE**

Conductive metalwork (inc. cable glands) must be a minimum of 5 mm away from the terminals.

- b. After cable termination has been completed, the cover can be reinstalled to the terminal box using the four M4 screws. Ensure the gasket is properly seated to maintain the IP rating. Do not over-tighten the cover screws.

- c. Ensure that all unused wire entries are sealed with the provided component certified black nylon M20-1.5 X 6H stopping plugs.

2. Models WV450XE 110 and 220 Vac.

**NOTE**

Maximum wire gage is 2.5 mm<sup>2</sup> (12 AWG)

Use wire rated 85° C or higher.

Ensure only stranded or multiple strand cable is used to terminate the WV450X.

a. Unscrew the four M4 screws and lift off the terminal box cover. The terminal block is supplied with 3 poles, 4 conductors per pole. The terminal blocks allow for easy supply in and loop out wiring to string beacons in series. Wire insulation to be stripped 8 mm to 9 mm (0.33 in). The terminal block uses a spring clamp connection to engage the wire. To disengage the clamp, insert a 2 mm blade tip screwdriver into the small openings closest to the terminal labels as shown in Figure 4. Insert the stripped wire into the larger opening and remove the screwdriver to engage the wire clamp. Connect the line (hot) power source wire to the terminal block pole marked “L/+”. Connect the neutral (common) power source wire to the terminal block pole marked “N/-”. Connect the ground wire to the terminal block pole marked with the ground symbol. Use Figure 3 for reference. When using more than one single or multiple strand lead, the connection into either side of any terminal must be joined in a suitable manner, e.g., two conductors into a single insulated crimped bootlace ferrule.

**NOTE**

Leads connected to the terminals shall be insulated for the appropriate voltage and this insulation shall extend to within 1 mm of the metal of the terminal throat.

**NOTE**

Conductive metalwork (inc. cable glands) must be a minimum of 5 mm away from the terminals.

b. After cable termination has been completed, the cover can be reinstalled to the terminal box using the four M4 screws. Ensure the gasket is properly seated to maintain the IP rating. Do not over-tighten the cover screws.

c. Ensure that all unused wire entries are sealed with the provided component certified black nylon M20-1.5 6H stopping plugs.

#### IV. MAINTENANCE.



To prevent ignition of hazardous atmospheres, disconnect the fixture from the supply circuit before opening. Do not open when an explosive gas atmosphere is present.

High voltages are present inside the light assembly. Wait at least 5 minutes after disconnecting the power before servicing this unit.

##### A. *General.*



#### **POTENTIAL ELECTRIC STATIC CHARGING HAZARD**

If the unit requires cleaning, then **ONLY** clean exterior with a water dampened cloth to avoid electrostatic charge build-up.

During the working life of the unit, it should require little or no maintenance. GRP will resist attack by most acids, alkalis and chemicals and is as resistant to concentrated acids and alkalis as most metal products. However, if abnormal or unusual environment conditions occur due to plant damage or accident etc. then visual inspection is recommended.

#### **SAFETY MESSAGE TO MAINTENANCE PERSONNEL**

Listed below are some important safety instructions and precautions you should follow:

- Read and understand all instructions before operating this system.
- Any competent site personnel can carry out the replacement of the xenon tube. Other repairs should be undertaken by returning the unit to Federal Signal Corporation or by an authorized repairer of Ex equipment.
- If you acquired a significant quantity of units, then it is recommended that spares are also made available.
- Any maintenance to the light system must be done with power turned off.
- Any maintenance to the light system must be performed by a trained electrician who is thoroughly familiar with all applicable national and local codes in the country of use.
- Never alter the unit in any manner. Safety of the unit may be affected if additional openings or other alterations are made to the internal components or housing.
- The nameplate, which may contain cautionary or other information of importance to maintenance personnel, should **NOT** be obscured in any way. Ensure that the nameplate remains readable.
- After performing any maintenance, test the light system to ensure that it is operating properly.



## B. *Flash Tube Replacement.*

As strobe lights are used, the flash tubes begin to darken, causing the light output to decrease. This darkening is characteristic of flash tubes. Darkening will begin near the base of the tube and progress upward. Also, as flash tubes age, they may have a tendency to misfire (not fire periodically).

After extended operation, occasionally check for flash tube degradation. Should the flash tube misfire, have a noticeable decrease in light output, glow continuously or darken -it should be replaced.



High voltages are present inside the light assembly. Wait at least 5 minutes after disconnecting the power before servicing this unit.

To change the strobe tube, proceed as follows:

1. Disconnect power.
2. Loosen the grub screw located on the lens cover assembly.
3. Remove the lens cover assembly from the housing by rotating the cover counterclockwise. If the lens cover assembly will not unscrew, back out the grub screw a few additional turns.
4. Grasp the flash tube by its base and pull it out of the socket, using a gentle “rocking” motion. Insert the new flash tube. Ensure the strobe lamp is firmly seated in the socket.



To maintain the explosion-proof integrity of the enclosure, DO NOT damage the globe or threads while disassembling or reassembling unit. Lubricated joints exposed for long periods of time may attract small particles of dirt or other foreign materials. Body and cover joints should be reassembled immediately.

5. Reinstall the lens cover assembly to the housing by rotating the cover clockwise. There should be a maximum gap of 0.3mm between the faces of the housing and cover to ensure o-ring compression for an environmental seal.
6. Tighten the lens cover assembly grub screw until snug.
7. Test the light for proper operation.

C. *Cleaning the Enclosure.*



The circuit must be turned OFF and allowed to cool to the surrounding ambient temperature before cleaning.

Fixture should be cleaned periodically to maintain maximum light output. Only clean the exterior with a water dampened cloth to avoid electro-static charge build-up. The glass globe should be regularly inspected for scratches and chips, and, if damaged, must be replaced.

D. *Service.*

Federal Signal will service your equipment and provide technical assistance with any problems that cannot be handled locally by Federal Signal's Distributor or Manufacturer Representative.

Any units returned to Federal Signal for service, inspection, or repair must be accompanied by a Return Material Authorization number with a brief explanation of the service being requested and/or the nature of the malfunction. This R.M.A. can be obtained from a local Federal Signal Distributor or Manufacturer's Representative.

In order to expedite service, please refer to the product model number and serial number on the label the serial number is interpreted as follows:

G0616400000	G = Factory Product Code
	06 = Last two digits for year of manufacture
	164 = Numerical day code for year of manufacture
	00000 = five digit code for product serial number.

Address all communications and shipments to:  
FEDERAL SIGNAL CORPORATION  
Industrial Systems Division  
Service Department  
2645 Federal Signal Drive  
University Park, IL 60484-3167  
USA

E. *Replacement Parts.*

Description	Part Number
Cover Lens Assy., Amber	K8595116-AA
Cover Lens Assy., Blue	K8595116-BA
Cover Lens Assy., Clear	K8595116-CA
Cover Lens Assy., Green	K8595116-GA
Cover Lens Assy., Red	K8595116-RA
Cover Lens Assy., Yellow	K8595116-YA
Cover Lens Assy., Magenta	K8595116-MA
Flash Tube/Trigger Coil Assy.	K8107177
Circuit Board, 24-48 Vdc, 5 joules	K2001926-01
Circuit Board, 24-48 Vdc, 10 joules	K2001926-02
Circuit Board, 24-48 Vdc, 15 joules	K2001926-03
Circuit Board, 110 Vac, 5 joules	K2001921-01
Circuit Board, 110 Vac, 10 joules	K2001921-02
Circuit Board, 110 Vac, 15 joules	K2001921-03
Circuit Board, 110 Vac, 21 joules	K2001921-07
Circuit Board, 220 Vac, 5 joules	K2001921-04
Circuit Board, 220 Vac, 10 joules	K2001921-05
Circuit Board, 220 Vac, 15 joules	K2001921-06
Circuit Board, 220 Vac, 21 joules	K2001921-08
Dome Guard	K8595107

V. **EC DECLARATION OF CONFORMITY.**

Manufacturer's Name: Federal Signal Corporation  
Manufacturer's Address: 2645 Federal Signal Drive  
University Park, IL 60484-3167  
U.S.A.

Declares that the Product Type of Equipment Model Number(s): WV450X  
conforms to the following Standards:

CERTIFICATION.

UNDERWRITERS LABORATORIES, INC./DEMKO

- I. IECEx = IECEx 06.0010X
  - IEC 60079-0, 60079-1, 60079-7, 60529
- II. ATEX = UL DEMKO 06 ATEX 0425693X
  - EN 60079-0, 60079-1, 60079-7, 60529

Special Conditions for Safe Use:

- 1) Potential electric static charging hazard. Use only a water dampened cloth when cleaning the exterior of the unit.
- 2) Contact the manufacturer for information on the dimension of the flame-proof joints.

Table 1

Voltage	Model	I avg	Recommended over-current protection
24 Vdc	15 joules	900 mA	5 amps
	10 joules	640 mA	5 amps
	5 joules	400 mA	5 amps
48 Vdc	15 joules	450 mA	3 amps
	10 joules	320 mA	3 amps
	5 joules	200 mA	3 amps
110 Vac 50 Hz	21 joules	295 mA	2 amps
	15 joules	370 mA	3 amps
	10 joules	195 mA	3 amps
	5 joules	135 mA	3 amps
248 Vac 50 Hz	21 joules	300 mA	3 amps
	15 joules	295 mA	2 amps
	10 joules	180 mA	2 amps
	5 joules	85 mA	2 amps
240 Vac 50 Hz	21 joules	290 mA	2 amps
	15 joules	290 mA	2 amps
	10 joules	185 mA	2 amps
	5 joules	88 mA	2 amps
220 Vac 50 Hz	21 joules	265 mA	2 amps
	15 joules	264 mA	2 amps
	10 joules	200 mA	2 amps
	5 joules	88 mA	2 amps

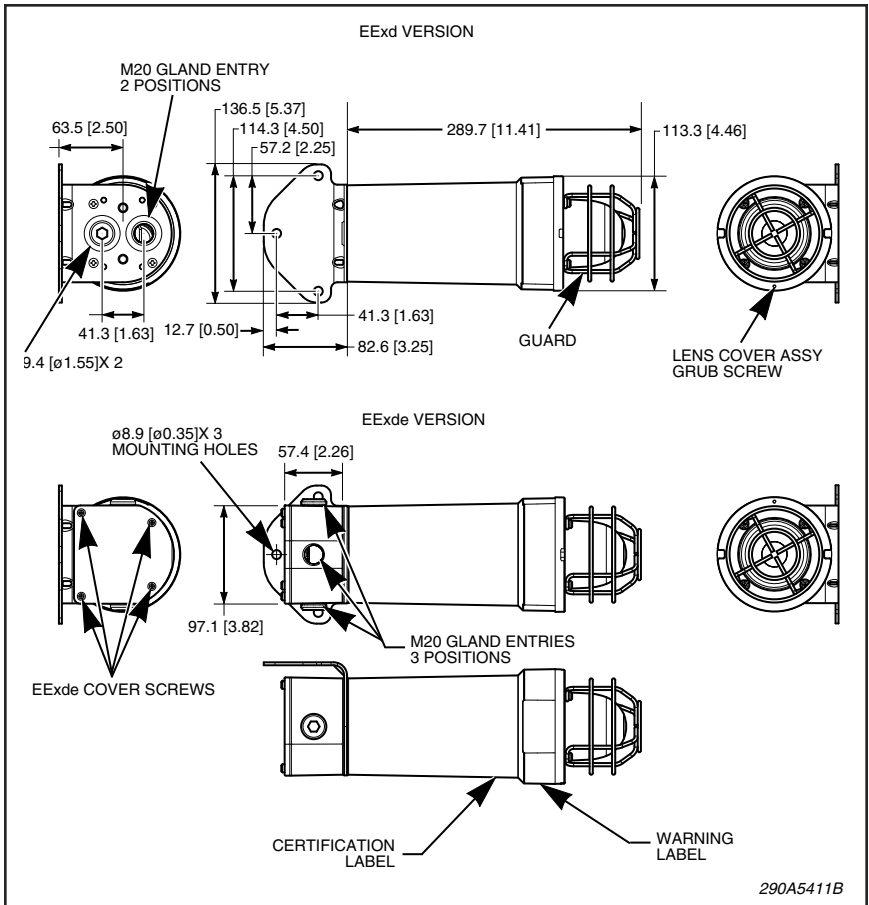

Figure 1.

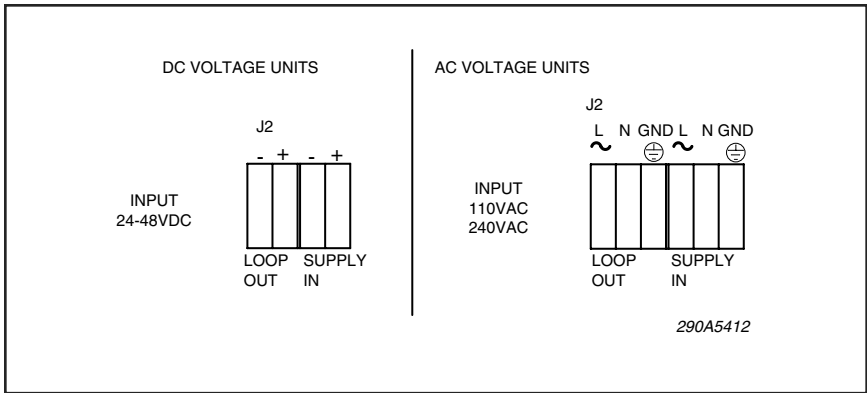

Figure 2.

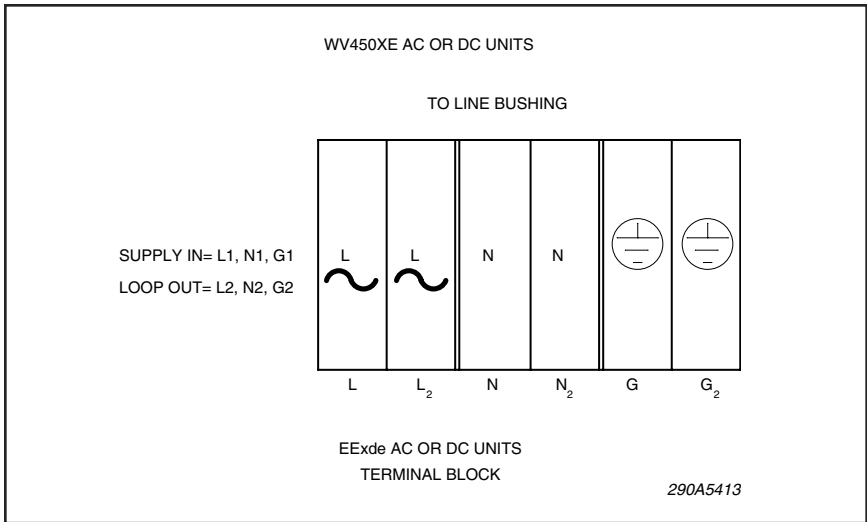
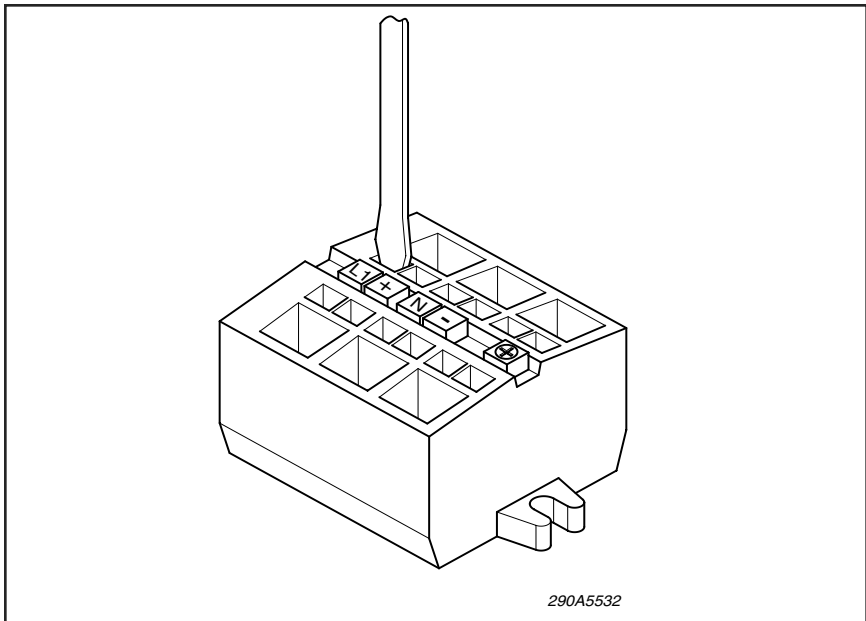

Figure 3.



290A5532

Figure 4.

