

**INSTRUCTION SHEET FOR MODEL 400HMK-AC
FOR
INSTALLATION OF FEDERAL MODEL 350 VIBRATONE HORNS
IN
FEDERAL MODEL 400 SERIES LIGHTS**

A. GENERAL

This sheet contains instructions for the installation of a Federal Model 350 Vibratone Horn in Federal Model 400 Series Warning Lights, enabling the user to assemble an integrated light/sound warning device. The instructions in this sheet are intended to be used in conjunction with the Installation Instructions for Model 400 Series Lights. It is usually most convenient to install the horn in the light before attaching the light to the mounting surface. However, the horn can be installed later, if required.

B. INSTALLATION

1. Check the parts received against the Kit Contents List, at the end of this sheet, to make sure that the installation kit is complete.
2. Insert first a grommet and then a bushing into each of the two holes, in both mounting brackets, as shown in figure 1.

3. Install the supplied gasket in the mounting box groove, as indicated in figure 1.
4. See figure 1. Connect the horn supply wires to the wires in the mounting box assembly, using the wire nuts supplied with the horn.
5. Attach the horn to the mounting box assembly, using the two 8-32 x 1-5/8" oval head screws supplied with the horn. Tighten the screws securely.

6. Remove and discard the two Phillips head screws from the front of the horn, as indicated in figure 2.
7. Apply the two adhesive foam seals to the holes from which the screws were removed in step 6. Ensure that there is a clear passage through the seals to the interior of the mounting box. These seals form a closed passage to minimize the accumulation of dust in the light assembly.

8. If the light has already been installed and in use, disconnect the power to the unit.

9. Detach the lower, metal, housing from the light assembly by removing the four slotted fastening nuts.

10. Attach the mounting brackets with the grommets and bushings that were installed in step 2, to the four exposed 8-32 x 5/8" studs, using the four elastic stop nuts supplied.

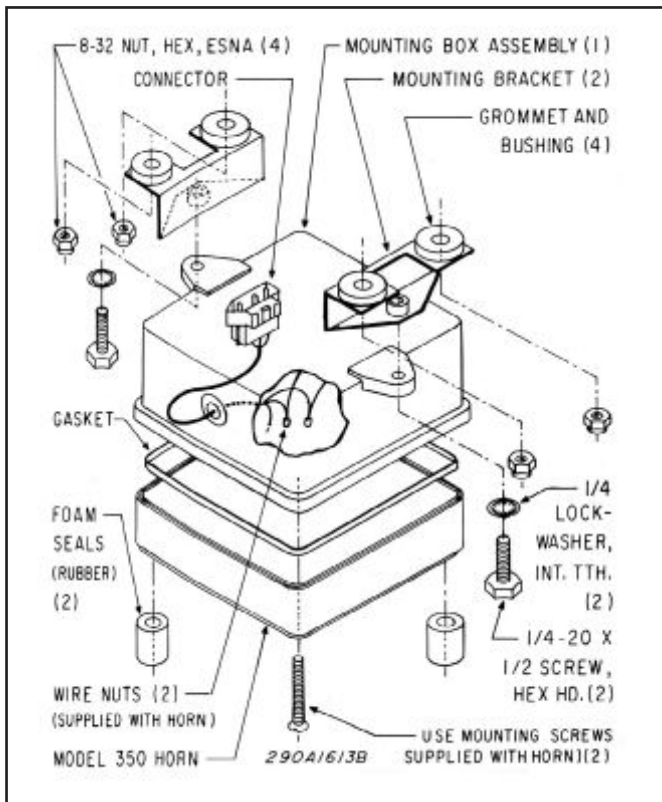

Figure 1.

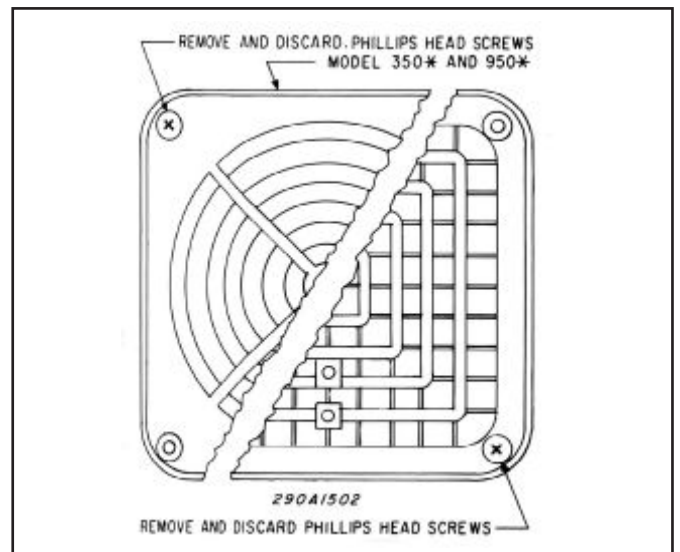

Figure 2.

11. Connect the receptacle from the horn assembly to the plug leading from the terminal block, on the light assembly.

12. Attach the horn to the mounting brackets, that were installed in step 10, using two 1/4"-20 x 1/2 hex head machine screws and lockwashers, as indicated in figure 1.

13. Remove the grille cover from the bottom of the lower housing by removing the four 6-32 KEPS nuts and washers at the bottom of the housing.

14. If the light/horn assembly is to be ceiling mounted, attach the light mounting bracket to the lower housing and reassemble the light before continuing with the procedure in the light installation sheet.

15. If the light/horn assembly is to be wall mounted, replace the lower housing on the assembly and install the unit following the installation instructions included with the light.

KIT CONTENTS LIST

<i>Qty.</i>	<i>Description</i>
1	Mounting Box Assy.
1	Gasket
2	Mounting Bracket
4	Grommet
4	Bushing
2	Foam Seal
2	Screw mach., hex hd., 1/4"-20
4	Elastic stop nut, 8-32
2	Lockwasher, 1/4"