

# Strobe Combination Audible/Visual Warning Signal

Model 400ST



## AUDIBLE AND VISUAL WARNING IN A SINGLE VERSATILE UNIT

- Available in 120VAC
- Five dome colors
- 10,000 hour strobe tube
- Wall mount
- Sounder/Horn (Model 350) sold separately
- Indoor / outdoor use
- Type 3R enclosure (In dome up orientation)
- UL and cUL Listed

Federal Signal's Model 400ST audible/visual signal combines the effective warning of a strobe light with an optional Federal Signal Model 350 horn.

The Model 400ST includes a fresnel lens, providing 360-degree flash coverage. Its strobe tube produces bright, high-intensity flashes at 400 effective candela at 75 flashes per minute.

Available in five dome colors: Amber, Blue, Clear, Green and Red.

The Model 400ST is ideal for use wherever both audible and visual warning signals are needed. This rugged unit is excellent for industrial use and adaptable to most in-plant signaling needs.

A modern housing design makes the Model 400ST suitable for use in institutional or non-industrial settings requiring an audible/visual alarm system, where heavy-duty industrial equipment might not be appropriate. Sounder/Horn (Model 350 and required 400HMK-AC) sold separately.

Model	Voltage	Operating Current	Flash Rate/Minute	Candela Peak <sup>1</sup>	ECP <sup>2</sup>	Mount
400ST-120*	120VAC 50/60Hz	0.6 amps	75	900,000	400	Wall/Surface

\* Indicates color: (A) Amber, (B) Blue, (C) Clear, (G) Green or (R) Red

<sup>1</sup> Peak candela is the maximum light intensity generated by a flashing light during its light pulse

<sup>2</sup> ECP (Effective Candela) is the intensity that would appear to an observer if the light were burning steadily



## STROBE AUDIBLE/VISUAL WARNING SIGNAL (400ST)

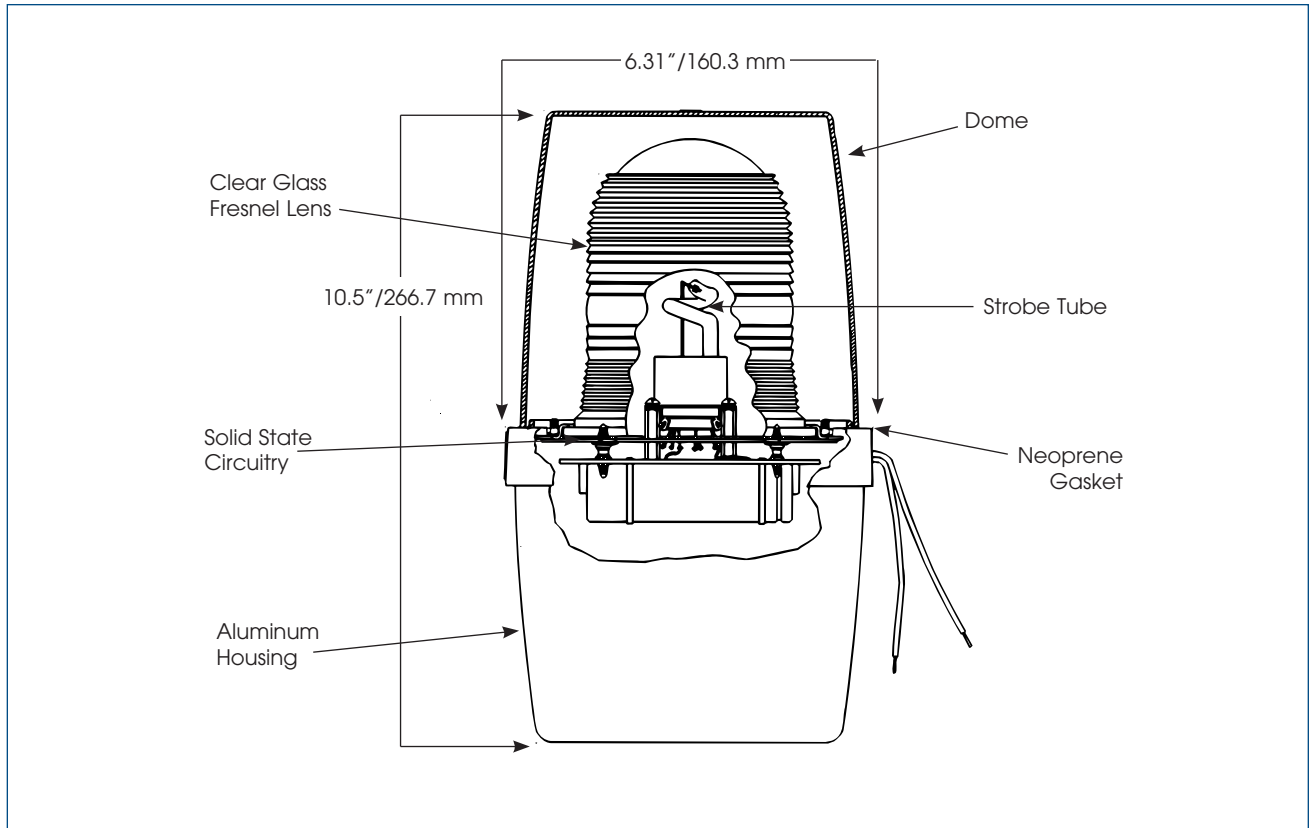

### SPECIFICATIONS

Lamp Life:	10,000 Hours	10,000 Hours
Light Source:	Strobe tube	Strobe tube
Operating Temperature:	-31°F to 150°F	-35°C to 66°C
Net Weight:	4.5 lbs.	2.0 kg
Shipping Weight:	5.1 lbs.	2.3 kg
Height:	10.5"	266.7 mm
Diameter:	6.31"	160.3 mm

### HOW TO ORDER

- Specify model, voltage and color
- Optional Accessories:  
Audible signaling horn (350)  
and required mounting kit  
(400HMK-AC) sold separately
- Please refer to Model Number Index  
400ST beginning on page 374

### REPLACEMENT PARTS

<i><b>Description</b></i>	<i><b>Part Number</b></i>
Exterior Dome, Amber	K8547C001A-04
Exterior Dome, Blue	K8547C001A-02
Exterior Dome, Clear	K8547C001A-05
Exterior Dome, Green	K8547C001A-03
Exterior Dome, Red	K8547C001A-01
Interior Fresnel Lens, Clear	K8248C004E-04
Strobe Tube	K8107178A
PC Assembly, 120VAC	K200D825E