

Electraflash® Flashing Lights



Model 141

DESIGNED FOR INDUSTRIAL OR VEHICULAR USE

- Available in 12VDC, 24VDC, and 120VAC
- Five dome colors
- Surface mount or integrated 1/2-inch NPT pipe mount
- Type 3R enclosure
- UL Listed and CSA Certified

Federal Signal's Electraflash® Model 141 is an economical incandescent flashing light. The Electraflash is less than six inches high and six inches in diameter. It is available in five impact-resistant fresnel dome colors: Amber, Blue, Clear, Green and Red. The 120VAC model is UL Listed and CSA Certified.

The Model 141 is available in 12VDC, 24VDC, and 120VAC. This light consists of a flasher unit with an incandescent bayonet lamp secured to its base (screw-in type lamp in 120VAC only).

The 12VDC and 24VDC units each provide three holes for easy flat surface mounting. The 120VAC unit is ready to mount on a 1/2-inch NPT pipe. Optional mounting brackets are available for the 120VAC unit, including the Model LWMB2 wall mount bracket and the Model LCMB2 corner mount bracket.

Federal Signal's economical flashing lights are designed for both indoor and outdoor environments. Model 141's convenient size and intense light output are ideal for maintenance vehicles, fork lifts, and other material handling equipment. The Electraflash can effectively identify hazardous conditions or dangerous areas.

Federal Signal's Electraflash is a compact warning light designed specifically for use in light-duty industrial applications.

Model	Voltage	Operating Current	Flash Rate/ Minute	Candela	Mount
141-012 *	12VDC	3.00 amps	70	325	Surface
141-024 *	24VDC	0.90 amps	70	125	Surface
141-120 *	120VAC 50/60Hz	0.38 amps	70	275	1/2" NPT Pipe

* Indicates color: (A) Amber, (B) Blue, (C) Clear, (G) Green or (R) Red



ELECTRAFLASH® FLASHING LIGHT (141)

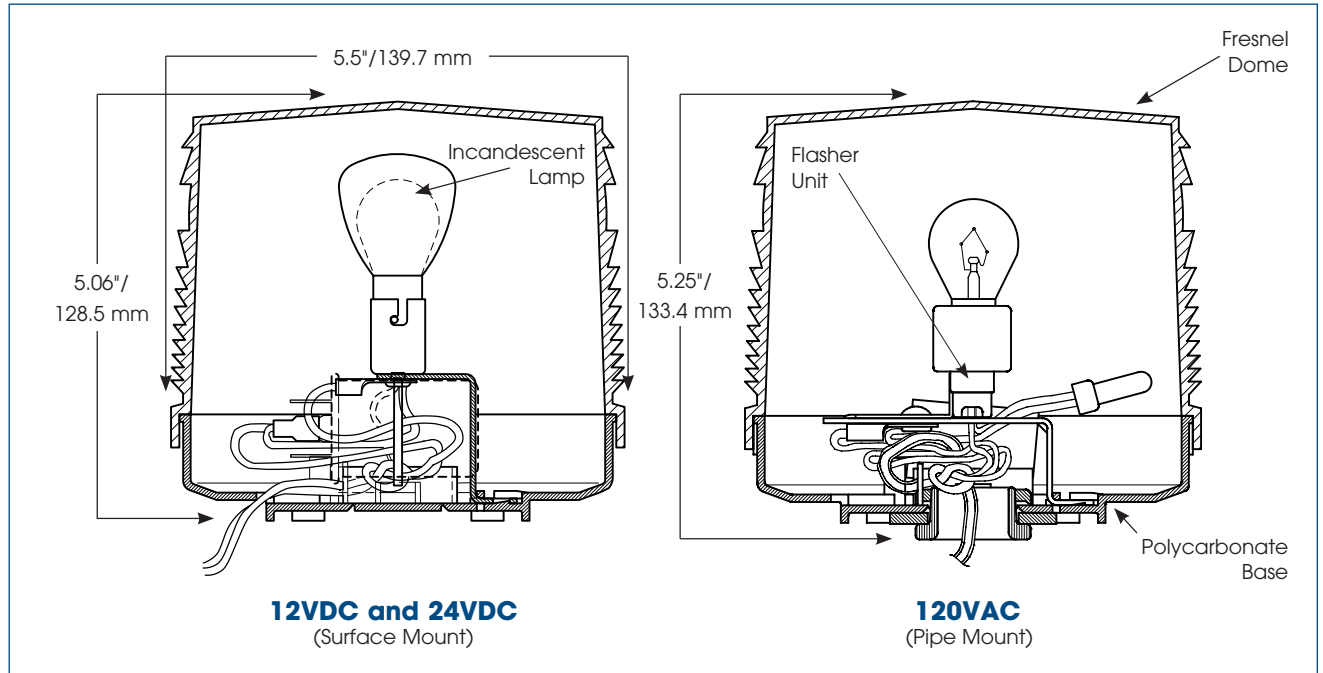

SPECIFICATIONS

Lamp Life:		
12VDC - Incandescent	1,000 Hours	1,000 Hours
24VDC - Incandescent	7,000 Hours	7,000 Hours
120VAC - Incandescent	7,000 Hours	7,000 Hours
Operating Temperature:		
DC Versions	-31°F to 150°F	-35°C to 66°C
Net Weight:		
DC Versions	0.8 lbs.	0.4 kg
AC Version	1.0 lb.	0.5 kg
Shipping Weight:		
DC Versions	1.1 lbs.	0.5 kg
AC Version	1.3 lbs.	0.6 kg
Height:		
DC Versions	5.06"	128.5 mm
AC Version	5.25"	133.4 mm
Diameter:		
DC Versions	5.5"	139.7 mm
AC Version	5.5"	139.7 mm

HOW TO ORDER

- Specify model, voltage and color
- Optional Accessories: (120VAC only):
Corner Bracket (LCMB2)
Wall Bracket (LWMB2)
- Please refer to Model Number Index 141 beginning on page 370

REPLACEMENT PARTS

Description	Part Number	Description	Part Number
Dome, Amber	K8263073A	Incandescent Lamp (24VDC)	K8107213A
Dome, Blue	K8263073A-01	Incandescent Lamp (120VAC)	K8107181A
Dome, Clear	K8263073A-03	Flasher (12VDC)	K8263A083A
Dome, Green	K8263073A-04	Flasher (24VDC)	K8285237A
Dome, Red	K8263073A-02	Flasher (120VAC)	K8285238A-01
Incandescent Lamp (12VDC)	K8107212A	Pipe Mount Kit	K8263093A