



# AudioMaster® 100 Watt High-Powered Driver/Horn

Models AM100H-SB, AM100D, AM100T

## PUBLIC ADDRESS FOR INDUSTRIAL ENVIRONMENTS

- Eight ohm & transformer coupled versions
- 100 watt
- Re-entrant horn design
- Swivel mount
- Superb voice and tone reproduction
- Suitable for indoor or outdoor use
- AM100T meets IP67 design

Federal Signal's Model AM100H-SB speaker and AM100 drivers provide high-powered tone and voice output. The directivity of the AM100H-SB combined with the power handling capability of the AM100 allows sound coverage to be concentrated into very specific areas as required. The impedance of the AM100 drivers also allows this speaker/driver combination to be used with existing central amplifiers or siren controls.

### AM100H-SB

The weather- and corrosion-resistant construction of the AM100H-SB makes it suitable for use in harsh industrial environments. Despite its rugged construction, the AM100H is light enough to allow for easy installation in hard to reach locations. The AM100H provides excellent sound dispersion and superb frequency response.

### AM100D

With a flat frequency response from 300-3000Hz, the AM100D provides excellent voice and alert tone reproduction. The compression driver provides long term continuous square wave power handling capacity of 100 watt, making this driver loud and reliable. The rugged die-cast housing features a weatherproof finish.

### AM100T

The AM100T is a 70 Vrms tappable 100 watt compression driver with a wide frequency response range. This gives it superior sound quality and the capability to be tuned for greater or lesser volume at each installation. This model has four preset tap settings— 12.5, 25, 50 and 100 watt. The AM100T incorporates a sealed design and has an IP67 rating making it ideal for heavy dust and wash down applications. Connections are provided via internal screw terminals and can be fitted with the appropriate cable gland connector to seal the product from the environment.

| Model                 | Power Handling | Frequency Response | Impedance | Beam Width | Temperature    | Decibels @ |     |
|-----------------------|----------------|--------------------|-----------|------------|----------------|------------|-----|
|                       |                |                    |           |            |                | 10'        | 1m  |
| AM100H-SB with AM100D | 100 watt       | 300-3000Hz         | 8 ohm     | 30°        | -30°C to 50°C  | 120        | 130 |
| AM100H-SB with AM100T | 100 watt       | 200-5000Hz         | Tappable* | 50°        | -50°C to 200°C | 121        | 132 |

\* Preset tap settings 12.5, 25, 50 and 100 watt.



## HIGH POWERED HORN & DRIVER (AM100H-SB/AM100D/AM100T)

### AM100H-SB

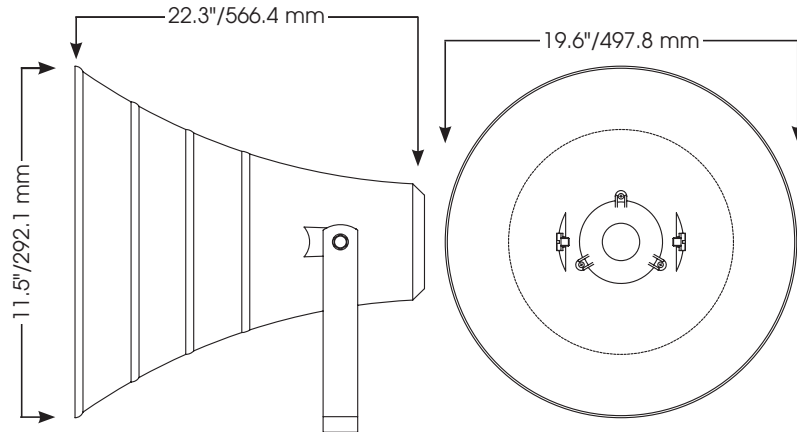

### AM100D

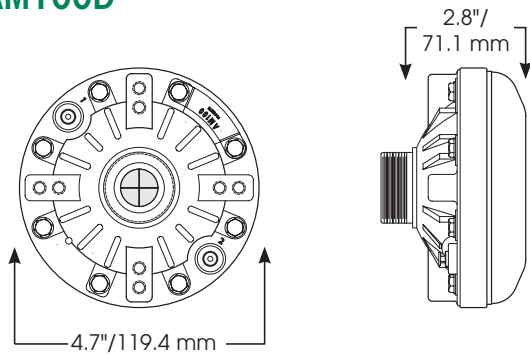

### AM100T

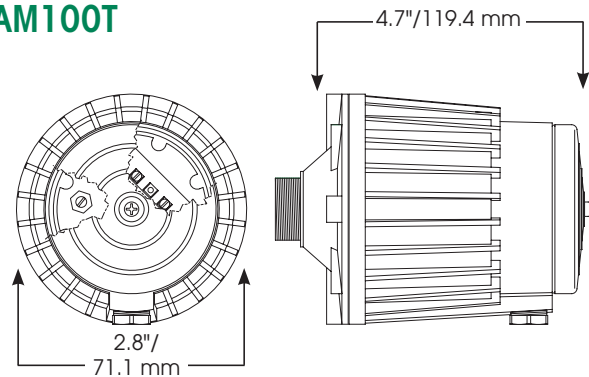

## SPECIFICATIONS

### AM100H-SB

|                  |          |          |
|------------------|----------|----------|
| Net Weight:      | 4.6 lbs. | 2.09 kg  |
| Shipping Weight: | 6.0 lbs. | 2.72 kg  |
| Width:           | 19.6"    | 497.8 mm |
| Height:          | 11.5"    | 292.1 mm |
| Depth:           | 22.3"    | 566.4 mm |

### AM100D

|                  |          |          |
|------------------|----------|----------|
| Net Weight:      | 4.3 lbs. | 1.95 kg  |
| Shipping Weight: | 5.0 lbs. | 2.27 kg  |
| Depth:           | 2.8"     | 71.1 mm  |
| Diameter:        | 4.7"     | 119.4 mm |

### AM100T

|                  |          |          |
|------------------|----------|----------|
| Net Weight:      | 5.5 lbs. | 2.5 kg   |
| Shipping Weight: | 6.5 lbs. | 2.96 kg  |
| Depth:           | 4.7"     | 119.4 mm |
| Diameter:        | 2.8"     | 71.1 mm  |

## HOW TO ORDER

- Specify model numbers (driver and horn)
- Please refer to Model Number Index AM100H-SB/ AM100D/AM100T beginning on page 377