

Federal Signal UltraVoice™ Personnel Alerting System

Including Models:

UltraVoice Indoor Controller (UVIC)

UltraVoice Audio and Relay Module (UVARM)

UltraVoice Local Operation Console (UVLOC)



INSTALLATION and OPERATION INSTRUCTIONS

255364F
4/07

Copyright 2007 Federal Signal Corporation

Federal Signal UltraVoice Installation and Operation Manual

SAFETY NOTICES

People's lives depend on your selection of suitable equipment and installation sites and your safe installation, service, and operation of our products. Federal Signal recommends the following publications from the Federal Emergency Management Agency for assistance with planning an outdoor warning system: 1. The "Outdoor Warning Guide (CPG 1-17), 2. "Civil Preparedness, Principles of Warning" (CPG 1-14), 3. FEMA-REP-1, Appendix 3 (Nuclear Plant Guideline), and 4. FEMA-REP-10 (Nuclear Plant Guideline). Contact Federal Warning System's Customer Care Center at: <http://www.federalwarningsystems.com> or 1-800-524-3021 for further information about these publications.

It is important to read, understand and follow all instructions shipped with this product. In addition, listed below are some other important safety instructions and precautions you should follow.

PLANNING

- If suitable warning equipment is not selected, the installation site for the siren is not selected properly or the siren is not installed properly, it may not produce the intended optimum audible warning. Follow Federal Emergency Management Agency (FEMA) recommendations.
- If sirens or speakers are not activated in a timely manner when an emergency condition exists, they cannot provide the intended audible warning. It is imperative that knowledgeable people, who are provided with the necessary information, are available at all times to authorize the activation of the sirens or speakers.
- When sirens are used out of doors, people indoors may not be able to hear the warning signals. Separate warning devices or procedures may be needed to effectively warn people indoors.
- The sound output of sirens is capable of causing permanent hearing damage. To prevent excessive exposure, carefully plan siren placement, post warnings, and restrict access to areas near sirens.
- Activating the sirens or speakers may not result in people taking the desired actions if those to be warned are not properly trained about the meaning of warning sounds. Siren users should follow FEMA recommendations and instruct those to be warned of correct actions to be taken.
- A siren or speaker that doesn't work won't provide any warning. After installation, service, or maintenance, test the mass notification system to confirm that it is operating properly. Test the system regularly to confirm that it will be operational in an emergency.

SAFETY NOTICES

Federal Signal UltraVoice Installation and Operation Manual

- If future service and operating personnel do not have these instructions to refer to, the siren system may not provide the intended audible warning and service personnel may be exposed to death, permanent hearing loss, or other bodily injury. File these instructions in a safe place and refer to them periodically. Give a copy of these instructions to new recruits and trainees. Also give a copy to anyone who is going to service or repair the siren.

People's lives depend on your safe installation, service and operation of our products. It is important to read, understand and follow all instructions shipped with this product. In addition, listed below are some other important safety instructions and precautions you should follow:

INSTALLATION & SERVICE

- Electrocutation or severe personal injury can occur when performing various installation and service functions such as making electrical connections, drilling holes, or lifting equipment. Therefore experienced electricians in accordance with national, state and any other electrical codes having jurisdiction should perform installation. All work should be performed under the direction of the installation or service crew safety foreman.
- The sound output of sirens or speakers is capable of causing permanent hearing damage. To prevent excessive exposure, carefully plan siren placement, post warnings and restrict access to areas near the sirens. Sirens and distributed speakers may be operated from remote control points. Whenever possible, disconnect all siren power including batteries before working near the siren.
- After installation or service, test the siren system to confirm that it is operating properly. Test the system regularly to confirm that it will be operational in an emergency.
- If future service personnel do not have these warnings and all other instructions shipped with the equipment to refer to, the siren or distributed speaker system may not provide the intended audible warning and service personnel may be exposed to death, permanent hearing loss, or other bodily injury. File these instructions in a safe place and refer to them periodically. Give a copy of these instructions to new recruits and trainees. Also, give a copy to anyone who is going to service or repair the sirens. For additional copies, call the Federal Warning Systems Customer Care Center at 800-524-3021 or write to them at 2645 Federal Signal Drive, University Park, IL 60466.

OPERATION

- Failure to understand the capabilities and limitations of your siren system could result in permanent hearing loss, other serious injuries or death to persons too close to the sirens when you activate them or to those you need to warn. Carefully read and thoroughly understand all safety notices in this manual and all operations-related-items in all instruction manuals shipped with equipment. Thoroughly discuss all contingency plans with those responsible for warning people in your community, company, or jurisdiction.

SAFETY NOTICES

Federal Signal UltraVoice
Installation and Operation Manual

WARNING

Read and understand the information contained in this manual, before attempting to install or service this product.

Pay careful attention to the following notices located on the equipment.

A. NOTICES - EXTERNALLY PLACED

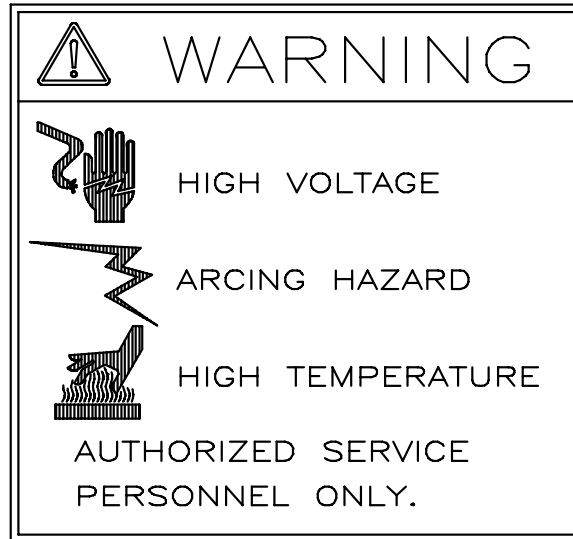

B. NOTICES-INTERNALLY PLACED

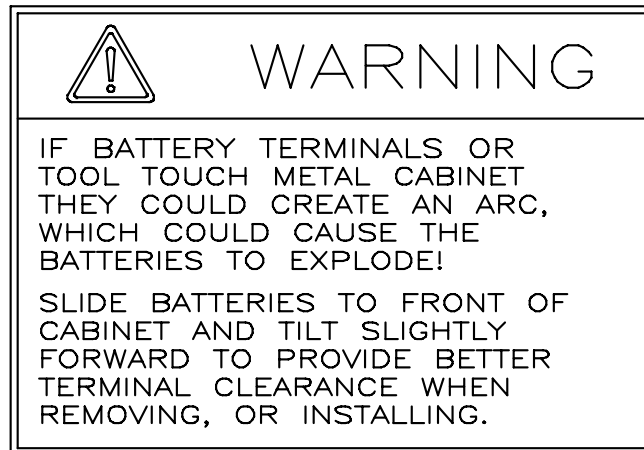

SAFETY NOTICES

Limited Warranty

*The Federal Warning Systems Division of **Federal Signal Corporation** warrants each new product to be free from defects in material and workmanship, under normal use and service, for a period of two years on parts replacement and factory-performed labor (one year for Informer, EAS, and Federal software products) from the date of delivery to the first user-purchaser. Federal Warning Systems warrants every 2001 & Eclipse Siren (Top of pole only) to be free from defects in material, per our standard warranty, under normal use and service for a period of five years on parts replacement.*

During this warranty period, the obligation of Federal is limited to repairing or replacing, as Federal may elect, any part or parts of such product which after examination by Federal discloses to be defective in material and/or workmanship.

Federal will provide warranty for any unit which is delivered, transported prepaid, to the Federal factory or designated authorized warranty service center for examination and such examination reveals a defect in material and/or workmanship.

This warranty does not cover travel expenses, the cost of specialized equipment for gaining access to the product, or labor charges for removal and re-installation of the product. The Federal Signal Corporation warranty shall not apply to components or accessories that have a separate warranty by the original manufacturer, such as, but not limited to, batteries.

Federal will provide on-site warranty service during the first 60-days after the completion of the installation, when Federal has provided a turn-key installation including optimization and/or commissioning services.

This warranty does not extend to any unit which has been subjected to abuse, misuse, improper installation or which has been inadequately maintained, nor to units which have problems related to service or modification at any facility other than Federal factory or authorized warranty service centers. Moreover, Federal shall have no liability with respect to defects arising in Products through any cause other than ordinary use (such as, for example, accident, fire, lightning, water damage, or other remaining acts of god).

THERE ARE NO OTHER WARRANTIES, EXPRESSED OR IMPLIED, INCLUDING BUT NOT LIMITED TO, ANY IMPLIED WARRANTIES OF MERCHANTABILITY OR FITNESS FOR A PARTICULAR PURPOSE. IN NO EVENT SHALL FEDERAL BE LIABLE FOR ANY LOSS OF PROFITS OR ANY INDIRECT OR CONSEQUENTIAL DAMAGES ARISING OUT OF ANY SUCH DEFECT IN MATERIAL WORKMANSHIP.



FEDERAL SIGNAL

Federal Warning Systems

2645 Federal Signal Drive, University Park, IL 60466

Phone: (800) 524-3021 Fax: (708) 534-4865

Website: <http://www.federalwarningsystems.com>

TABLE OF CONTENTS

Section	Page
SAFETY NOTICES.....	2
1.1 General Description.....	10
1.2 Model Number Descriptions.....	11
1.3 Standard Feature Descriptions:.....	11
1.4 Motherboard Description.....	17
1.5 Configuration.....	17
Unit Type.....	18
Unit Address.....	18
RF Frequency.....	19
Single-Tone, Two-Tone Timing.....	19
EAS Location Codes.....	19
128-bit Encryption Key.....	19
Security Key.....	20
User Programs.....	20
Available Functions:.....	21
2. SPECIFICATIONS.....	22
2.1 Electrical.....	22
2.2 Charger.....	22
2.3 Battery.....	23
2.4 Controller.....	23
Serial & I2C Ports.....	23
Signaling Formats.....	23
Audio Output to Amplifiers.....	24
2.5 Motherboard.....	24
Relay Output.....	24
600 Ohm Balanced Line Port.....	24
Remote Activation, Sensor and Direction Inputs.....	24
Expansion Slot.....	25
Amplifier Outputs.....	25
Motherboard Connectors.....	25
Indicators.....	28
Fuses.....	28
2.6 UVIC25SD.....	28
2.7 Controller Front Panel Controls, Jacks, Switches and Indicators.....	30
Controls:.....	30
Jacks:.....	30
Indicators:.....	31
Control Unit Connector Configuration.....	32
2.8 Audio Power Amplifier Modules Model (UV400).....	34
2.9 Audio and Relay Output Card Option (2005300).....	35
Connectors.....	35

Federal Signal UltraVoice
Installation and Operation Manual

Indicators.....	36
2.10 Model UVLOC	37
UVLOC Connectors.....	37
2.11 Alarm Panel Interface.....	37
Alarm Panel Interface Connectors.....	38
2.12 Environmental	39
2.13 Physical.....	39
3. UVIC OPERATION.....	40
3.1 Hardware General Description	40
3.2 Manual Activation.....	40
3.3 Local Public Address.....	41
3.4 Relay Output	41
3.5 600 Ohm I/O.....	41
3.6 Remote-Landline Activation	41
3.7 Sensor Inputs and Isolated Sensor Power	42
3.8 Spare Sensor Inputs.....	43
3.9 Two-Way Status Monitoring	43
3.10 Quiet Test.....	43
B. Finding Faults.....	43
3.11 Battery Charger	44
3.12 UVLOC.....	45
4. SYSTEM PLANNING	46
4.1 Control Unit	46
4.2 Speaker Placement.....	46
4.3 UVLOC Placement.....	47
5. INSTALLATION.....	48
5.1 UVIC Siren Controller Installation Reference Drawings	48
5.2 General Mounting Guidelines For All Applications	52
5.3 UVIC Installation Material List and Installation Guidelines	53
Concrete or Filled Cement Block Wall Mounting Guidelines:	53
Hollow Block Wall Mounting Guidelines:	53
Wood Stud Wall Mounting Guidelines:	54
Metal Stud Wall Mounting Guidelines:.....	55
5.4 Installer Supplied UVIC Electrical Installation Material List	56
5.5 Electrical Connections.....	57
Grounding Requirements	57
AC Power Connections	57
Wiring Guidelines for 120VAC Electrical Service	57
Wiring Guidelines for 240VAC Electrical Service	58
Battery Connections	58
5.6 Antenna Types	59
5.7 Cabinet Mounted Magnetic Base Antenna Installation	59
5.8 Remote Mounted Magnetic Base Antenna Installation.....	59
5.9 Yagi Antenna Installation.....	59

TABLE OF CONTENTS

Federal Signal UltraVoice
Installation and Operation Manual

Final VSWR Tuning.....	60
Yagi Antenna Mounting	61
5.10 Omni Antenna Installation	61
5.11 Speaker Connections	65
5.12 PA Audio Connections	65
5.13 Contact Closure Inputs.....	65
5.14 Optional UVARM Connections	65
5.15 Optional UVLOC Connections and Wall Mounting	66
5.16 External 24VDC Power Connections.....	66
5.17 600 Ohm I/O Connections.....	66
Control Connections.....	66
Audio Connections	66
5.18 Turning Power On	67
6. PRE-OPERATION CHECKOUT AND TEST	71
6.1 Visual Inspection	71
6.2 Amplifier and Speaker Pre-Operation Checkout	71
6.3 Radio Transceiver Adjustment Procedure.....	72
6.4 600 Ohm Level Adjustment Procedure for Communications.....	72
6.5 600 Ohm Adjustment Procedure for External Audio Source	73
6.6 Control and Status Monitoring.....	73
6.7 Optional UVLOC	73
7. MAINTENANCE	76
7.1 Control Unit Preventive Maintenance	77
7.2 General Maintenance.....	77
Signal Operational Check.....	77
Battery Check.....	77
7.3 Troubleshooting	78
8. OPTIONS	79
8.1 Radio Control	79
8.2 Digital Voice Recording	79
8.3 UVIC25ST Option.....	79
8.4 UVIC25SD Option	79
8.5 UVARM Option.....	79
8.6 UVLOC Option	80
8.7 Installation of User Supplied Radio Receivers	80
9. Final Assembly Drawing and Parts List.....	82

TABLE OF CONTENTS

TABLE OF FIGURES

Figure 1.1 - UVIC Parts Layout.....	13
Figure 1.2 – Control and Amplifier Identification	14
Figure 1.3 – UVARM Identification	15
Figure 1.4 – UVLOC Identification	16
Figure 2.1 - Motherboard Outline Drawing	29
Figure 5.1 - Typical UVIC Installation Drawing	48
Figure 5.2 - UVIC Cabinet Dimensional Outline Drawing	49
Figure 5.3 – UVIC Wiring Diagram	50
Figure 5.4 – UVIC Battery Connections.....	51
Figure 5.5 - Yagi Antenna Installation Example.....	62
Figure 5.6 - Omni Antenna Installation Example	63
Figure 5.7 – Antenna Grounding Example	64
Figure 5.8 – UVIC Strobe and Speaker Wiring.....	67
Figure 5.9 - UVLOC Interface Wiring Diagram	68
Figure 5.10 - UVLOC Dimensional Outline	69
Figure 5.11 – UVIC25SD Wiring Diagram	70
Field Test Data Sheet.....	75
Figure 9.1 – UVIC Final Assembly and Parts List (Page 1 of 2)	82
Figure 9.2 – UVIC25ST Wiring Detail	84

SECTION I

1.1 General Description

The UltraVoice Indoor Controller (UVIC) is designed to fulfill the need for an indoor electronic controller that is smaller and less expensive than the full size UltraVoice outdoor warning siren controller. It shares the same control board and amplifiers as the standard UltraVoice but is limited to 800 total Watts of amplifier power, and uses a single, wall-mountable NEMA1 / UL Type 1 rated enclosure that has a built-in lock.

The use of smaller, sealed VRLA AGM type batteries minimizes battery out-gassing and makes the controller better suited for indoor operation.

Model UVARM: The UVIC supports an optional Audio and Relay Output Module (model UVARM) that provides three audio outputs and four relay outputs to enable the UVIC to be connected to existing PA systems or other auxiliary devices.

Model UVLOC: An optional Local Operation Console (model UVLOC) enables users to control the UVIC from an easy to use pushbutton control panel. The panel is connected to the UVIC with a standard CAT5 network cable and may be located up to ½ mile away from the UVIC controller. The UVLOC is remotely powered from the UVIC and requires no local power source of it's own. The panel measures only 10" x 4.75" x 3" (L x W x D) and is easily wall mounted. The UVLOC provides control for 7 digital recordings: Live P.A., P.A. Recording from an integrated microphone, Recorded P.A. Playback, and two Auxiliary user programmable functions.

Model UVIC25ST: An optional 25 volt step-down transformer may be required to convert 70 volts to 25 volts, depending on location and installation.

Model UVIC25SD: An optional 25 volt step-down transformer may be required to convert 70 volts to 25 volts, depending on location and installation. The UVIC25SD includes two step-down transformers in a NEMA 4X fiberglass enclosure.

Model UVIC: The amplifiers and optional equipment are all modularly constructed to ease removal without disconnecting a large number of wires. In most instances, field service is limited to replacement of a slide out module, which can be performed by non-technical personal with only a screwdriver.

Activation codes, command sequences, and operating parameters are uploaded from an IBM compatible computer through the RS232 port located on the front panel or over the radio channel with the Federal Commander Digital System. All user information is stored in non-volatile FLASH memory, immune to power and battery failure.

Refer to Figures 1.1, 1.2, 1.3 and 1.4 for reference.

GENERAL DESCRIPTION

Federal Signal UltraVoice
Installation and Operation Manual

1.2 Model Number Descriptions

All UVIC models are set up for 2-way control and status monitoring using the Federal Commander Digital Control system including a 13.6V radio power supply and antenna lightning protector. All models include 8 minutes of digital voice storage. Custom digital voice recording requires a model DVR. All of the following models are available in a 240VAC version by adding a 240 to the model number i.e.: UVICH240.

<u>CONTROLLER OPTIONS</u>	<u>UVIC MODEL #</u>
NO RADIO (RF)	UVIC
UHF BAND Transceiver	UVICU
HIGH BAND Transceiver	UVICH
LOW BAND Transceiver	UVICL (Special Order)

1.3 Standard Feature Descriptions:

- Seven standard warning signals
- Up to 16 digitally stored voice messages; 8 minutes total recording time
- Local push-button control
- Local microphone for PA with hanger mounted in cabinet
- 8 remote contact closure inputs for activation
- Single tone, 2-tone, DTMF, EAS and MSK decoders for remote siren control
- MSK modem with 128-bit encryption for remote status monitoring over radio or wire
- 600 ohm I/O for wire-line control and status monitoring
- 15A relay output
- Quiet test - siren status monitoring
- Zoning - up to 8 zones per control cabinet for selective control of speaker outputs
- Power control ramps up siren or speaker volume for added safety, custom volume settings, and low power testing
- Stackable siren or distributed speaker functions enable user pre-defined warning scenarios
- Low band, VHF, or UHF radio transceiver options
- Modular design - no inter-board wiring, easy field service
- Windows[®] based siren programming software (optional)
- Cabinet:
 - Single NEMA1/UL type 1, powder coated steel cabinet
 - Single lockable door hasp that can be easily opened without tools
 - Wall mountable
 - 8 multi-size knockouts for conduit entrances
 - Bulkhead mounted type N female antenna connection

GENERAL DESCRIPTION

Federal Signal UltraVoice Installation and Operation Manual

- Amplifiers (Model UV400):
 - 2 amplifier slots for 400 Watt amplifiers, 70Vrms
 - Optionally, one UV400 with a UVIC25ST (25Vrms step-down transformer)
 - 12 speaker pair connections per amplifier

- Audio and Relay Output Module (UVARM) Option:
 - Balanced 33 ohm output
 - Balanced 600 ohm output
 - Selectable balanced or single-ended 600 ohm line-level output
 - Four SPDT relay outputs

- Local Operation Console (UVLOC and UVLOC-IM) Option:
 - Operator interface panel for controlling 7 digital messages, Live P.A., Record and Playback functions, plus two user programmable functions.
 - Remotely powered from the UVIC controller
 - LED status indicators
 - Balanced 600 ohm output
 - CAT5 wiring interface

- Batteries:
 - 44 A/H (min), sealed VRLA AGM type
 - Over 45 minutes full sounding battery backup without AC power

- Battery Charger:
 - 24 VDC, 10A
 - Temperature compensated

GENERAL DESCRIPTION

Federal Signal UltraVoice Installation and Operation Manual

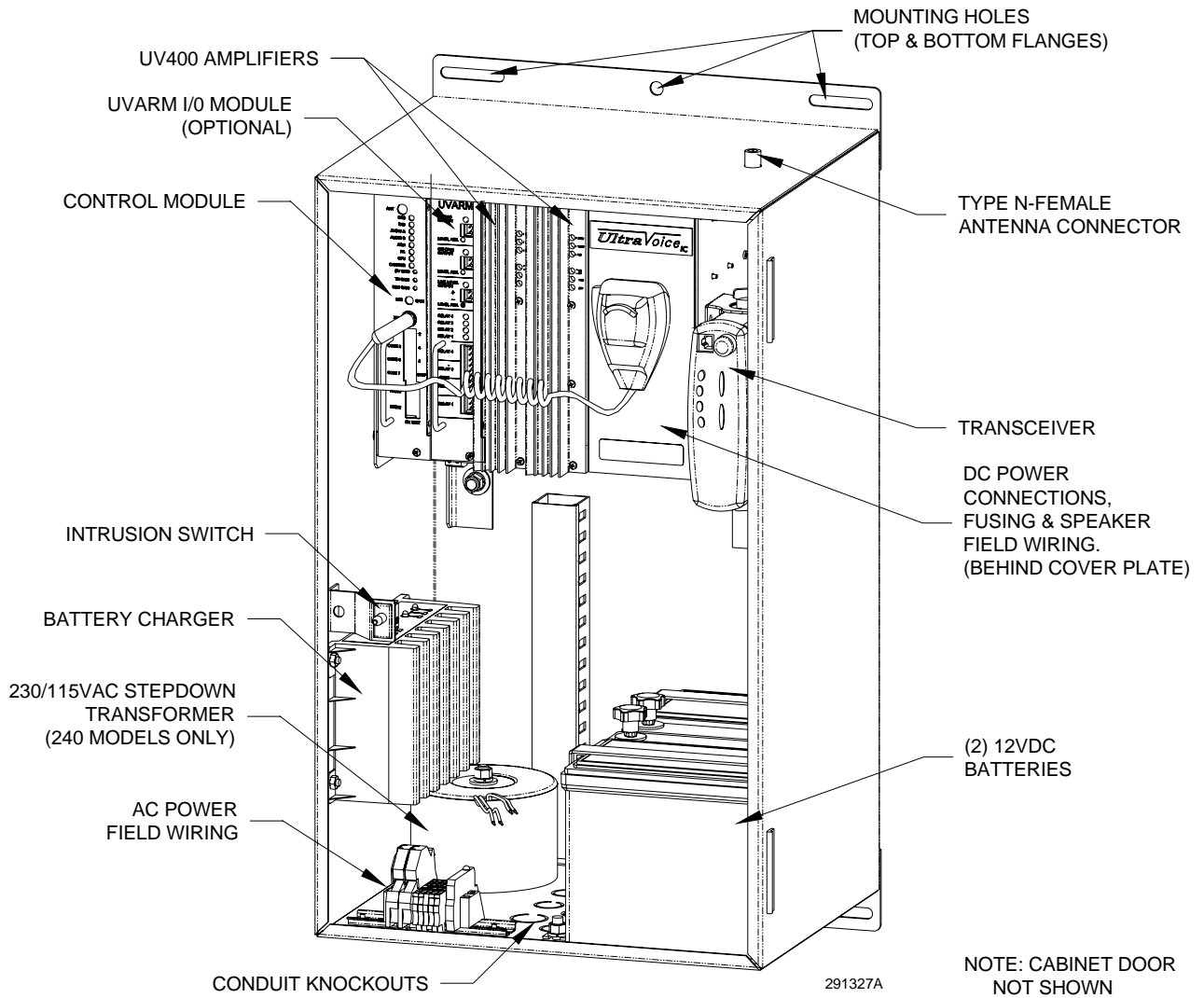
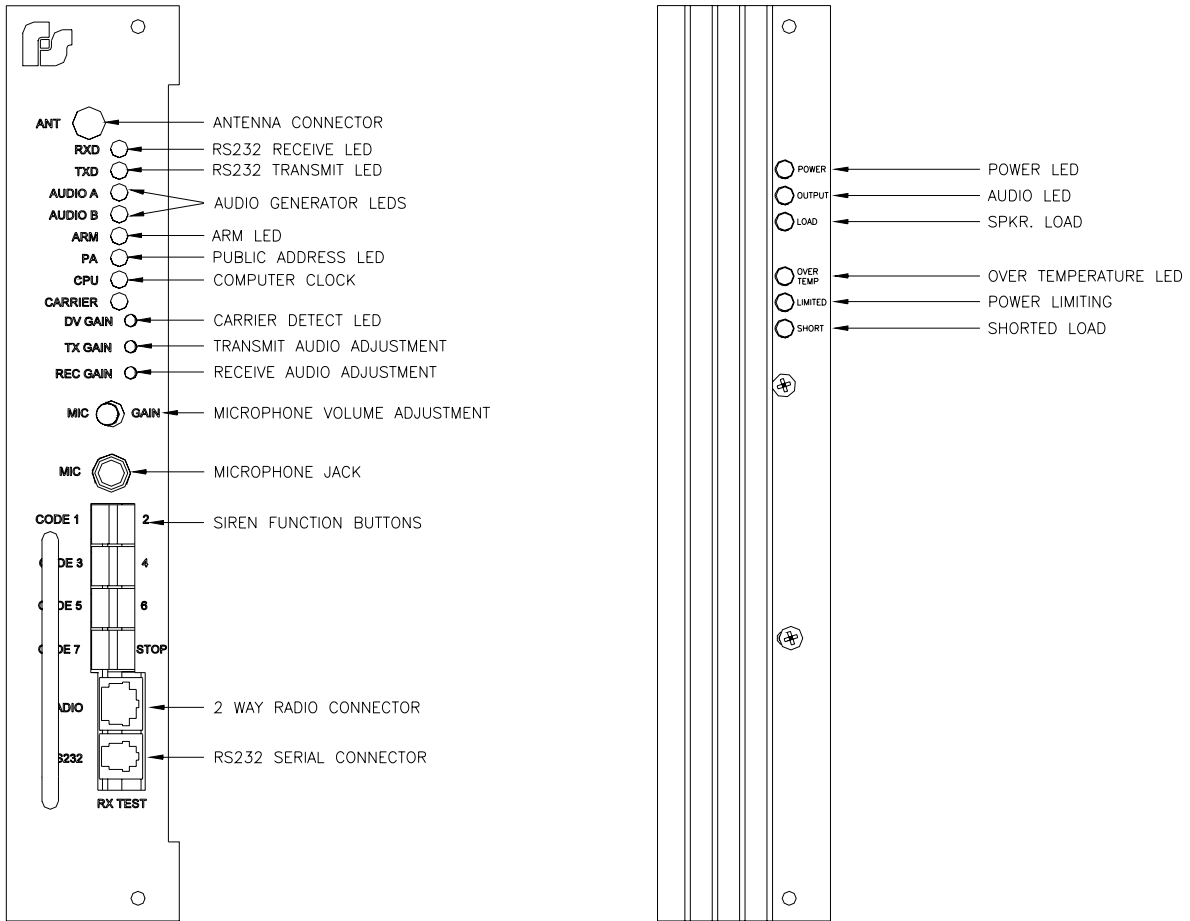

Figure 1.1 - UVIC Parts Layout

GENERAL DESCRIPTION

Federal Signal UltraVoice Installation and Operation Manual



UV CONTROL AND AMPLIFIER

291169B

Control

Amplifier

Figure 1.2 – Control and Amplifier Identification

GENERAL DESCRIPTION

Federal Signal UltraVoice
 Installation and Operation Manual

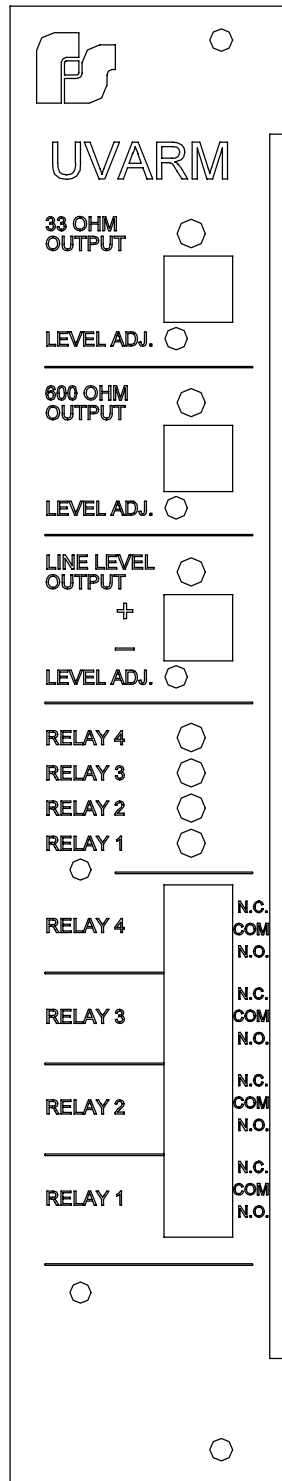

291328A

Figure 1.3 – UVARM Identification

GENERAL DESCRIPTION

Federal Signal UltraVoice Installation and Operation Manual

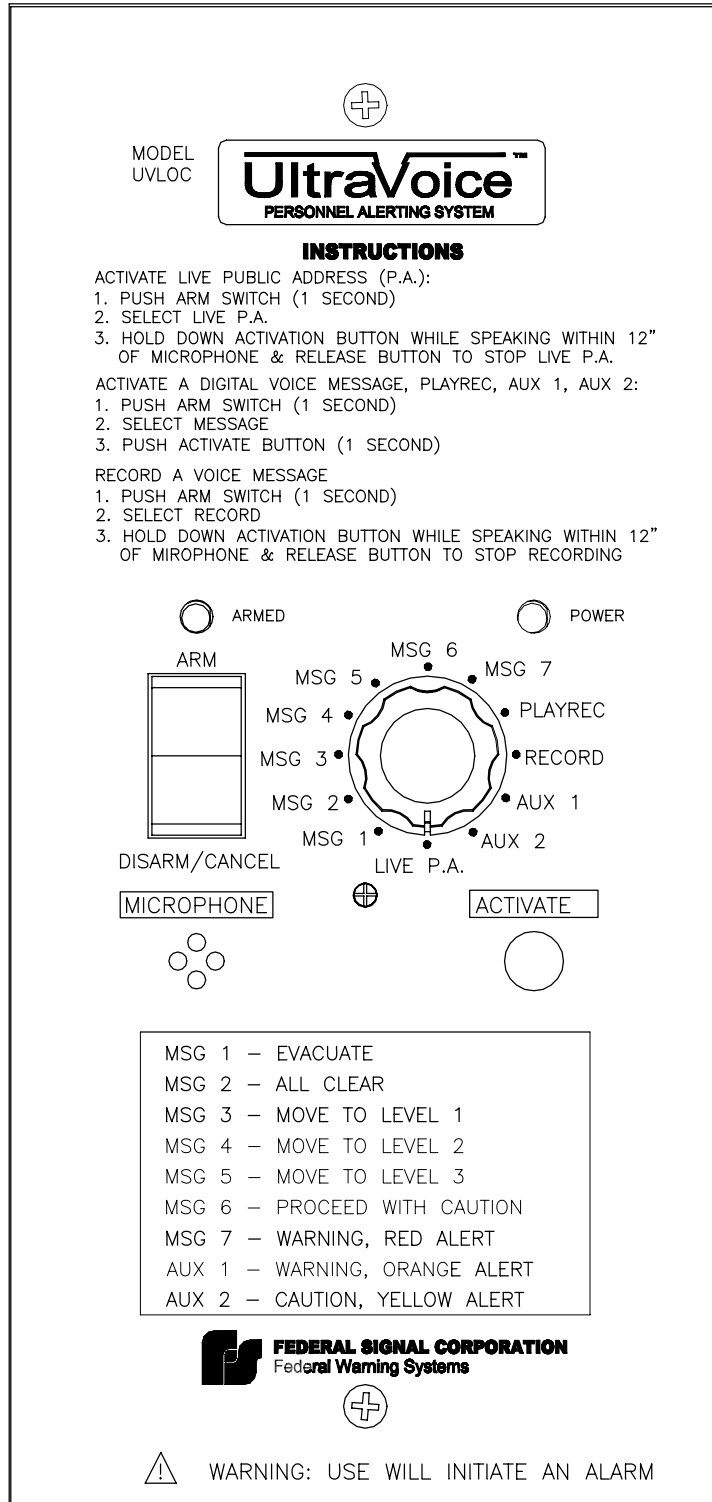

291340A

Figure 1.4 – UVLOC Identification

GENERAL DESCRIPTION

1.4 Motherboard Description

The Motherboard for the UVIC is a scaled down 800 Watt version of the 3200 Watt UltraVoice product. The board is primarily a passive back plane that provides the electrical connections between the Microprocessor Control board, the Audio and Relay output board, and the UV400 amplifiers. In addition, it provides connections for field wiring and a relay output.

The UVIC Motherboard is limited to two amplifier slots. It uses the same style connectors as the UltraVoice except for the removable fused 50A, 24VDC power input and the 50A, 24VDC output connector.

The Motherboard has a fused normally open relay output. The relay is normally programmed to close while a control function is active. An LED indicator turns on when the relay is active.

Capacitor C1 and inductor T1 are used to filter the 24VDC power source. This filtered power is fused by F2 and is routed to JP1, JP2, JP6 and JP7.

1.5 Configuration

Each modular UltraVoice siren contains the following configuration parameters, which are configured by the user:

1. Unit Type
2. Unit Address (see below)
3. RF Frequency
4. Single-Tone or Two-Tone Timing (A-time, B-time, S-time)
5. EAS Location Codes
6. 128-bit Encryption Key
7. Security Key

Federal Signal UltraVoice Installation and Operation Manual

Unit Type

The Unit Type is set to the type of siren this unit is controlling, and is usually determined by the number of cells in the speaker array. When setting up the unit type, the user selects from a menu with the following choices:

- UV1 1 - UV400 Amplifier, 400 Watts total power
- UV2 2 - UV400 Amplifiers, 800 Watts total power

Unit Address

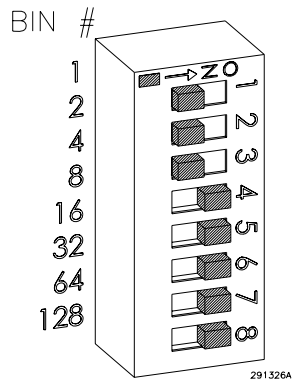

Address Switch

The Unit Address is a three-digit number with a range of 001-255. The unit address is set via dipswitch S1. S1 Off position indicates active position. Add binary active switch positions to get ID address.

Switch number	1	2	3	4	5	6	7	8
Binary number	1	2	4	8	16	32	64	128

Example: Switch number 1, 2 & 3 is binary number 1, 2 & 4, which when added, would equal unit address 7.

Programming details are in the software manual. The ID address is stored at power up of the controller. If the ID address is changed, the power (battery and AC) must be turned off and then on.

RF Frequency

For units equipped with the optional integral radio receiver, the RF Frequency configuration parameter sets the frequency of the radio channel. Changing this parameter from its factory setting may require re-alignment of the radio for maximum performance. The value entered must fall within the range specified for the receiver band equipped.

Single-Tone, Two-Tone Timing

For Two-Tone activated units, the Two-Tone Timing parameters set up the time duration of the activation tone codes. The three parameters, A-Time, B-Time, and S-Time; sets the time duration for the A-tone, B-tone, and Single-Tone respectively. Note: The Two-Tone timing parameters are minimum values only. The actual tone times may be longer than the specified times.

EAS Location Codes

Up to three location codes may be assigned for EAS activation. For activation to occur, the location code of the received EAS message must match one of the three assigned codes.

Units cannot be programmed for both Tone and EAS activation at the same time. Therefore, when using EAS decoding, the A-Time, B-Time, and S-Time parameters above must be set to zero. The UVIC is capable of being programmed for EAS, DTMF and Federal Digital decoding at the same time. Refer to www.fcc.gov for further information about EAS messages.

128-bit Encryption Key

For MSK activated units, 128-bit data encryption provides security against malicious operation or monitoring. The 128-bit key is programmed during the flashing of the microprocessor and must match the encoder (SS2000D or SFCDWARE) being used to activate the unit. A key value of zero disables 128-bit encryption and must be used if the encoder does not support 128-bit encryption. All sites in the system must use the same encryption key.

Federal Signal UltraVoice Installation and Operation Manual

Security Key

For MSK activated units, the Security Key is a unique number assigned to the system that prevents nearby systems operating on the same RF frequency from interfering. Like the 128-bit encryption key, the Security Key is programmed during the flashing of the microprocessor and must match the encoder. The exception is a key value of 65535 (the default), defined as an “open” system and will communicate with all encoders regardless of the encoder’s key setting.

User Programs

The UVIC has the capacity to store up to fifty (50) user programs. Each user program contains the following elements:

- 1) Optional DTMF Activation Code
- 2) Optional Two-Tone Activation Code
- 3) Optional EAS Event Code
- 4) List of up to 20 functions

The ability to assign more than one function to each activation code or user program is a new feature not previously found in electronic sirens. This allows the user to run a sequence of functions without sending additional activation commands, greatly enhancing flexibility while reducing operator involvement and communication channel traffic.

Federal Signal UltraVoice
Installation and Operation Manual

Available Functions:

Arm
Disarm
Report
Master Reset
Cancel
PA Output
Quiet Test
Low Power Mode
Hi Power Mode
Zone A (Rotating Sirens Only)
Zone B (Rotating Sirens Only)
Zone C (Rotating Sirens Only)
Zone D (Rotating Sirens Only)
Wail
Pulsed Wail
Alt Wail
Steady
Pulsed Steady
Alt Steady
Auxiliary (Chime)
Delay
Digital Voice (1-16)
Amp/Audio Zone Control
Power
Report
Record PA Message
Play Recorded PA Message
RelayN On (N = Relay#)
RelayN Off (N = Relay#)

The SFCDWARE program is required to configure the UVIC. Refer to the SFCDWARE Reference Manual for a full description of all available functions.

SECTION II

2. SPECIFICATIONS

2.1 Electrical

AC Input Voltage	120 or 240VAC 50-60Hz* (*two separate models)
AC Input Current	5 amps maximum
Battery Input Voltage	20-28VDC, 24 volts (nominal)
Battery Current	120 mA standby current, +18 to 22 amps for each amplifier module running, 50A maximum
Battery Capacity	>45 minutes continuous operation without AC power
Stand By Time	>72 hours (3 days) including 2-way radio (with 5-minute full signal reserve min.)

2.2 Charger

Current Limit	Protected with automatic recovery
EMI/RFI Filtering	Meets FCC requirements
Input	115VAC (50-60Hz), 3.5A maximum
Output Voltage	26 – 30VDC (temperature compensated)
Output Current	0 -10 amps DC

Federal Signal UltraVoice
Installation and Operation Manual

2.3 Battery

Battery Voltage (72F)	27.2VDC nominal
Recommended Batteries:	NorthStar model: NFB12-180 HAZE model: HZB12-44
Type	VRLA
Rating	44A/H minimum

CAUTION: Substituting batteries may be hazardous and will void warranty.
Use specified batteries only.

2.4 Controller

Serial & I2C Ports

Serial Port Protocol	RS232C 1200,N,8,1
I ² C Port Protocol	Philips Standard I ² C

Signaling Formats

Number of codes	Up to 50 activation codes max.
Two-Tone Sequential or Single Tone	282Hz - 3000Hz 0.5 sec (A) - .25 sec (B) minimum to 8 sec maximum
DTMF	3 to 12 digits standard 50ms/50ms timing or greater
AFSK	1200,N,8,1 (MSK 2-way modem)
EAS	AFSK, 520.83 baud
Modem Tones	2083.3Hz and 1562.5Hz
Number of functions allowed stacked under each code	Up to 20

SPECIFICATIONS

Federal Signal UltraVoice
Installation and Operation Manual

Audio Output to Amplifiers

Output Voltage Swing	>9V peak-to-peak (p-p)
Maximum Load	600 ohms
Total Harmonic Distortion	< 10% w/1KHz sine-wave

2.5 Motherboard

Relay Output

Contact Rating	30VDC, 15A
----------------	------------

600 Ohm Balanced Line Port

Audio Input Level	0.10 to 2 volts p-p to make 1 volt p-p TP10
Audio Output Level	0.25 to 2.0 volts p-p

Remote Activation, Sensor and Direction Inputs

Number of Remote Activation Inputs	8
Number of Remote Sensor Inputs	4
Number of Direction Sense Inputs	4
Input Type	Optically isolated activated by Dry contact closure < 2 k ohms

SPECIFICATIONS

Federal Signal UltraVoice
Installation and Operation Manual

Expansion Slot

The expansion slot contains the same connector pin-out as the controller slot.
Signals available:

- Two I²C Ports
- 600 Ohm Balanced Port
- +5VDC
- +24VDC
- PTT
- AUDIO-A and AUDIO-B
- Open-Collector Output (for Rotator Relay)
- Charger Indicator
- 4 Remote Sensor Inputs
- 8 Remote Activation Inputs
- 4 Direction Sensor Inputs

Amplifier Outputs

Number	12 speaker connection/amp
Rating	22-14 AWG

Battery Connection 50A at 30VDC

Remote Power Output 50A at 30VDC

Radio Power Output 20A at 30VDC

(To 12V DC-DC converter - radio fused at 15 amps)

Motherboard Connectors

CONNECTOR DESIGNATION	PURPOSE
JP1	ULTRAVOICE Controller Interconnect
JP2	Expansion Port/Audio Relay Output Port
JP3	Amplifier 1 Interconnect
JP4	Amplifier 2 Interconnect
JP5	24VDC Battery Input, fused @ 50 amps Pin 1 Ground

SPECIFICATIONS

Federal Signal UltraVoice
Installation and Operation Manual

	Pin 2 24VDC
JP6	Unfiltered 24VDC Output (for accessories) Pin 1 Ground Pin 2 24VDC
JP7	Filtered 24VDC Output (for radio power 12V DC-DC converter) Pin 1 Ground Pin 2 +24VDC
JP8-JP10	Not Used
JP11	20A DC, Normally Open Relay Output:
JP12	600 ohm Transformer Balanced Audio I/O -See controller JP8 jumper - Requires PTT @ JP15-10
JP13	Filtered 24VDC Power Output Pin 1 Ground Pin 2 +24VDC
JP14	Remote Activation Input Pins: 1,10 ISO Ground 2 Function 1 3 Function 2 4 Function 3 5 Function 4 6 Function 5 7 Function 6 8 Function 7 9 Function 8
JP15	Sensor Inputs Pins: 1,3,5,7,9,11 ISO Ground 2 Spare #1 4 Intrusion 6 Solar 8 AC Power 10 600 Ohm PTT 12 Spare #2
JP16	Isolated Power Supply

SPECIFICATIONS

Federal Signal UltraVoice
Installation and Operation Manual

Pins:

- 1 5 (-)
 - 2 5 (+)
- 150mA max current
for external equipment

JP17

Spare Sensor Input

Pins:

- 1 ISO Ground
- 2 SPR3 -active low
- 3 SPR4 -active low
- 4 SPR5 -active low
- 5 SPR6 -active low

JP18

Expansion Port, Secondary Cabinet

Pins:

- 1 Ground
- 2 I²C VCC 5
- 3 Serial Clock 2
- 4 Serial Data 2
- 5 Amplifier Audio Signal 1
- 6 Amplifier Audio Signal 2

JP19

Test Speaker (listen to receive audio)

Pins:

- 1 Receive Audio (same as TP6 on control board)
- 2 Ground

JP20

Charger Sensor Input

Pins:

- 1,3 Ground
 - 2 Input from Charger
- See JP4 on controller board

JP21

Amplifier 1 Output

Pins:

- 1 - 12 SIG -

JP22

Amplifier 1 Output

Pins:

- 1 - 12 SIG +

JP23

Amplifier 2 Output

Pins:

- 1 - 12 SIG -

SPECIFICATIONS

Federal Signal UltraVoice
Installation and Operation Manual

JP24	Amplifier 2 Output Pins: 1 - 12 SIG +
JP29	Expansion Port, Primary Cabinet Pins: 1 Ground 2 I2C VCC 5 3 Serial Clock 1 4 Serial Data 1 5 Amplifier Audio Signal A 6 Amplifier Audio Signal B

Indicators

D2	Relay Output LED
----	------------------

Fuses

(F1) Relay Fuse @JP11	AGC 20A, 40VDC
(F2) 24VDC Output @JP13	AGC 10A, 32VDC
(F3) 24VDC Input @JP5	JJN-50L, 50A, 160VDC

2.6 UVIC25SD

Input Voltage	70VAC rms
Output Voltage	25VAC rms
Power Rating	400 Watts

SPECIFICATIONS

Federal Signal UltraVoice Installation and Operation Manual

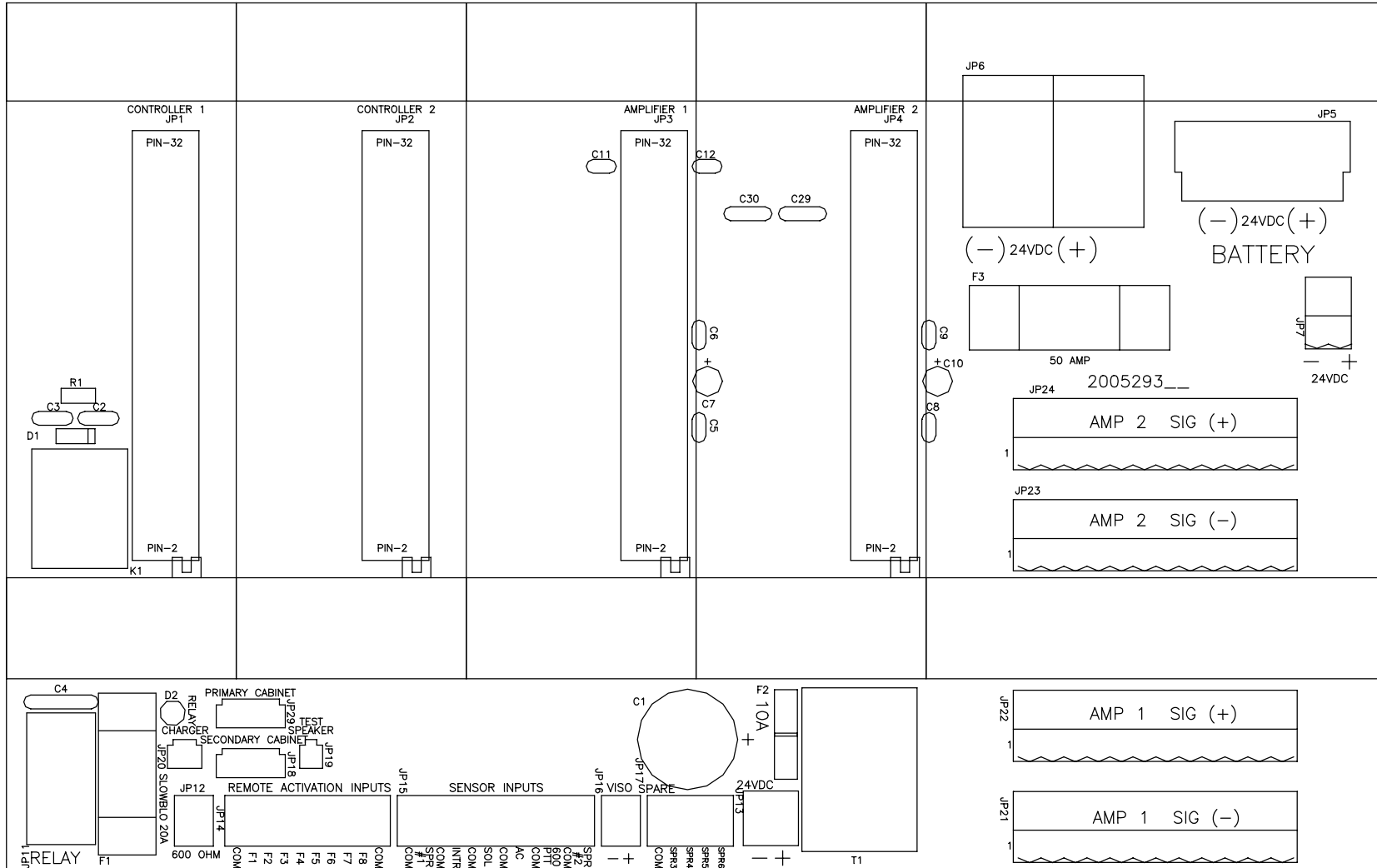

Figure 2.1 - Motherboard Outline Drawing

SPECIFICATIONS

Federal Signal UltraVoice
Installation and Operation Manual

2.7 Controller Front Panel Controls, Jacks, Switches and Indicators

Controls:

DV GAIN	Internal Digital Voice Level sufficient to drive TP1 or TP2 into clipping
TX GAIN	Transmitted Audio Adjustable from 50mv to 1 volt peak-to-peak (p-p)
REC GAIN	Received Audio Level 150 mV to 3 volts p-p
MIC GAIN	Local PA Level range sufficient to drive amplifiers into clipping w/50 mV nominal input level

Jacks:

MIC	10k ohms input impedance, 50mv nominal input level
XCVR	External Receiver or Transceiver
Receive audio level required to make 1 volt peak to peak at TP10	150 mV to 3 volts peak-to-peak
Transmit Audio Output	50mv to 3 volt peak-to-peak
Carrier Detect Input	Less than 1 volt DC to make active
PTT Output	Active low, will sink 500 mA maximum
12Vdc	+/- 0.2 volts, 1.0 amps maximum
Ground	1.5 amps max current capacity
I ² C	5 volts peak-to-peak +/- 1 volt input 5 volts DC +/- .2 volts 250 mA Ground 250mA maximum sink
RS232 Serial Port	RS232 standard, 1200 baud,N,8,1

SPECIFICATIONS

Federal Signal UltraVoice
Installation and Operation Manual

Manual Activation Switches: QTY 8, activate with a hold time >0.50 seconds

Indicators:

RXD	Receive Serial Data & receipt of radio channel modulation
TXD	Transmit Serial Data & DTMF & Digital
AUDIO A	Audio present on Channel A
AUDIO B	Audio present on Channel B
ARM	Unit Armed indicator
PA	Public Address mode indicator
CPU	Microprocessor Heartbeat
CARRIER	RF Carrier indicator on w/carrier present

SPECIFICATIONS

Federal Signal UltraVoice
Installation and Operation Manual

Control Unit Connector Configuration

Refer to tables below for description of connectors in control assembly.

Connectors for 2005141 PCB	
CONNECTOR DESIGNATION	PURPOSE
JP1	On-Board Receiver Module Connector Pins: 1 Ground 2 +8V 3 Clock 4 Data 5 Latch Enable 6 Carrier Detect Not 7 De-Emphasized Receive Audio 8 Flat Receive Audio
JP2	Inter Board Connections
JP3	SINAD Pin 1: Ground Pin 2: SINAD
JP4	Battery Charger Sense: -Jumper out: used with battery charger Pass on >3VDC@JP20-2 -Jumper in: Used with solar, Pass on 1 VDC less than battery voltage@JP20-2
JP5	Short to force Carrier Detect 1 Carrier Detect 2 Ground
JP6	External Radio Connector Pins: 1 RX Audio In 2 TX Audio Out 3 Carrier Detect 4 PTT 5,7 12VDC for Radio 6,8 Ground

SPECIFICATIONS

Federal Signal UltraVoice
Installation and Operation Manual

Connectors for 2005141 PCB – Continued	
CONNECTOR DESIGNATION	PURPOSE
JP7	CTCSS Connector Pins: 1 RX Audio In 2 Ground 3 8VDC for CTCSS Board 4 Audio Switch 5 TX CTCSS Tone
JP8	600 Ohm Configuration Jumper -See motherboard JP15 and JP12 Pins: Jumpered is active 2-3 Activation audio from JP12 1-2 PA mode - External audio source at JP12 - Level adjusted by R111
JP9	Receiver Priority Pins: 1-3 External Receiver Priority 2-4 Internal Receiver Priority
JP10	Digital Disable Jumper Pins 1-2 to disable Digital Decoder
JP11	SINAD Jumper Pins 1-2 to enable SINAD Board Note: JP9 Must have both 1-3 & 2-4 jumpered when SINAD is used
J1	Microphone Jack Tip Audio In Ring PTT Sleeve Ground

SPECIFICATIONS

Federal Signal UltraVoice
Installation and Operation Manual

2.8 Audio Power Amplifier Modules Model (UV400)

Input voltage	24VDC nominal 28VDC maximum
Input Current Siren mode	@ 24VDC w/1KC square-wave into 11 ohms: <20 amps
Input Current Voice Mode	@ 24VDC w/1KHz tone set to 67VRMS into 11 ohms: <24 amps
Standby current at amps turned off	<10 milliamps
Efficiency	>90% - siren mode >80% - voice mode
Output voltage into 11 ohms @1KHz and 24VDC nominal operating voltage	67VRMS minimum - siren mode 67VRMS minimum - voice mode
Input impedance	100K ohms
A to D sensor accuracy	< +/- 10%
Duty Cycle, Continuous Signaling Times	
Siren Mode	30 minutes
Digital Voice or PA	30 minutes(depending on signal source)
Audio distortion	< 10% - voice mode – below clipping
Frequency response	+/- 3dB, 300 – 3000Hz
Power Low Power mode	< 5 Watts per amplifier
Ripple on power supply w/all amps running at rated power in siren mode	0.5 volt peak-to-peak maximum

SPECIFICATIONS

Federal Signal UltraVoice
Installation and Operation Manual

2.9 Audio and Relay Output Card Option (2005300)

Input voltage	13.5 - 30
Input current	200 mA maximum
Balanced 33 ohm output	Adjustable from 0.2 – 1.9VRMS
Balanced 600 ohm output	Adjustable from 0.2 – 3VRMS or -12 to +11dB, surge protected
Single-ended or balanced Line-level/600 ohm output	Adjustable from 0.2 – 3VRMS
Relay outputs	4 SPDT
Contact rating	20A @ 30VDC with NO & NC contacts

Connectors

Wire Size	All front panel connectors 22-14 AWG
P1, Back plane 48 pin EPT male card edge connector	
JP1, 33 ohm audio output 1 & 2 balanced output	
JP3, 600 ohm audio output 1 & 2 balanced output	
JP7, 600 ohm/line level audio output 1 & 2 balanced output or 1 - signal 2 - ground	
JP6, 2 pin shorting jumper Shorted makes JP7 unbalanced output Open makes JP7 balanced output	
JP2, 3 pin shorting jumper Short pins 1 & 2 to select channel A audio for JP1 output Short pins 2 & 3 to select channel B audio for JP1 output	

SPECIFICATIONS

Federal Signal UltraVoice Installation and Operation Manual

JP4, 3 pin shorting jumper

Short pins 1 & 2 to select channel A audio for JP3 output

Short pins 2 & 3 to select channel B audio for JP3 output

JP5, 3 pin shorting jumper

Short pins 1 & 2 to select channel A audio for JP7 output

Short pins 2 & 3 to select channel B audio for JP7 output

JP8, Relay Outputs

1 - Relay #1, N.O.

2 - Relay #1, COM

3 - Relay #1, N.C.

4 - Relay #2, N.O.

5 - Relay #2, COM

6 - Relay #2, N.C.

7 - Relay #3, N.O.

8 - Relay #3, COM

9 - Relay #3, N.C.

10 - Relay #4, N.O.

11 - Relay #4, COM

12 - Relay #4, N.C.

Indicators

LED D18, Power

LED D1, 33 ohm output active

LED D3, 600 ohm output active

LED D5, Line level output active

LED D11, Relay #1 energized

LED D10, Relay #2 energized

LED D9, Relay #3 energized

LED D8, Relay #4 energized

SPECIFICATIONS

Federal Signal UltraVoice
Installation and Operation Manual

2.10 Model UVLOC

Operating Voltage:	20 - 32VDC
Operating Current:	< 25 mA
Digital Outputs:	Four BCD encoded, 1 amp current sink maximum
Audio Output:	600 ohm balanced, adjustable 700 mVpp to 5 Vpp
Maximum Distance between Control Panel and UV:	Approx 1/2 mile of cable, ≤ 200 ohms of cable
Maximum Number of Control Panels per UV:	10 (external wire management required)
UV-Control Panel Interface Cable:	CAT5, 4 pairs
Size (L x W x D)	10" x 4.75" x 3" maximum

UVLOC Connectors

- JP2 & JP1, RJ45 and 8 position terminal strip wired in parallel:
- 1 - 600 Ohm Audio
 - 2 - 600 Ohm Audio
 - 3 - Direction Input # 3
 - 4 - Direction Input # 2
 - 5 - Direction Input # 1
 - 6 - Direction Input # 0
 - 7 - Power
 - 8 - Ground

2.11 Alarm Panel Interface

Operating Voltage:	20 - 32VDC
Operating Current:	< 50 mA
Digital Outputs:	Four BCD encoded, 10 mA current sink max.
ARM Input:	0 – 5VDC, 5VDC = ARMed
ARM Output:	7.4 – 8.0VDC Not ARMed, 20 – 32VDC ARMed
Environmental:	Indoor Use, -30C to +65C, non-condensing humidity

SPECIFICATIONS

Federal Signal UltraVoice
Installation and Operation Manual

Alarm Panel Interface Connectors

JP2, JP3, JP4, JP5, JP7, JP8, six RJ45s and one 8 position terminal strip wired in parallel;

- 1 – Ground
- 2 – Power
- 3 – Direction Input # 0
- 4 – Direction Input # 1
- 5 – Direction Input # 2
- 6 – Direction Input # 3
- 7 – 600 Ohm Audio
- 8 – 600 Ohm Audio

JP1, 10 position connections to UV back-plane;

- 1 – Ground
- 2 – Power
- 3 – ISO Ground
- 4 – Direction Input # 3
- 5 – Direction Input # 2
- 6 – Direction Input # 1
- 7 – Direction Input # 0
- 8 – ARM
- 9 – 600 Ohm Audio
- 10 – 600 Ohm Audio

SPECIFICATIONS

Federal Signal UltraVoice
Installation and Operation Manual

2.12 Environmental

Operating Temperature	-30°C - +65°C
Humidity	0-98% non-condensing

Notes:

1. The UVIC can operate throughout this temperature range provided the battery temperature is maintained at -18°C or higher.
2. The UVIC housing carries a NEMA 1 rating

2.13 Physical

UV400 amplifiers	10.5" height, 2.0" width, 8.5" depth, weight 4.12 lbs, 1.9 kg
Control cabinet	31" height, 17.36" width, 13.62" depth 78.73 cm x 44.09 cm x 35.59 cm
Weight	130 lbs/ 58.97 kg (including batteries)
Net Shipping Weight	200 lbs/ 90.72 kg (including batteries)

SPECIFICATIONS

SECTION III

3. UVIC OPERATION

3.1 Hardware General Description

The UVIC contains a card cage with four plug-in boards consisting of; one controller slot, one optional accessory slot and two amplifier slots. The UVIC uses one amplifier card for a 400 Watt system and two amplifiers for an 800 Watt system. All siren control, audio generation and remote communication functions are handled by a single

microcomputer controlled control board. The back-plane (motherboard) contains connectors and terminal blocks for wireless interconnection of the other system components. To facilitate field service, no active circuitry is located on the back-plane. Power for the siren is supplied by two 12 volt batteries.

3.2 Manual Activation

The manual activation switches located on the face of the controller are used to manually activate siren functions.

Function Switch	Function
FUNC1	Activates Functions under code 1
FUNC2	Activates Functions under code 2
FUNC3	Activates Functions under code 3
FUNC4	Activates Functions under code 4
FUNC5	Activates Functions under code 5
FUNC6	Activates Functions under code 6
FUNC7	Activates Functions under code 7
FUNC8	Reset
FUNC1 & FUNC6	Load default speaker calibration values & send a DTMF calibration tone
FUNC2 & FUNC3	Calibrate speaker load
FUNC5 & FUNC7	Digital Transmit Deviation tone

NOTE: At any time during a sounding function the "RESET" button may be pushed to cause the unit to halt all output immediately.

3.3 Local Public Address

The operator has the ability to give local Public Address (PA) messages using the model MNC-MC microphone provided. PA mode can be entered simply by pressing the press-to-talk (PTT) button on the MIC while the MIC is plugged into the 1/4" receptacle on the front panel. The PA LED will be lit anytime the PTT button on the microphone is pressed. The local PA volume level is set by adjusting the MIC GAIN knob located directly above the MIC jack.

NOTE: Local PA overrides ALL siren functions activated either remotely or locally.

3.4 Relay Output

Terminal block JP11 at the bottom of the system motherboard is the relay output. This relay closes whenever a siren function is running. In PA mode, the relay closes for approximately 30 seconds when the PTT button is released. The relay is open while the MIC PTT button is pushed.

3.5 600 Ohm I/O

Terminal block JP12 at the bottom of the system motherboard is the 600 ohm input/output connector. This port can be used to make connections for activation and status monitoring of the unit over wire-lines. It can also be used to connect external audio sources to the amplification system.

3.6 Remote-Landline Activation

Terminal block JP14 at the bottom of the system motherboard is the Remote Activation input. There are eight inputs available on JP14. The electronic siren controller can optionally be operated by separate remote dry contact closures provided across this input.

Any of the codes, which means all of the functions programmed for that code, can be activated by providing a momentary, dry contact closure between "COM" and the desired JP14 terminal. For example, shorting "F1" to "COM" will activate whatever is programmed for code #1, and shorting "F2" to "COM" will activate whatever is programmed for code #2 and so on.

Provide a momentary contact closure between JP14 "COM" and "F8" (RESET) if desired to terminate an activated signal before it runs for the full duration.

Remote Activation Connections

JP14 Terminal	Function
1	"Common"
2	"F1"
3	"F2"
4	"F3"
5	"F4"
6	"F5"
7	"F6"
8	"F7"
9	"F8"
10	"Common"

3.7 Sensor Inputs and Isolated

Terminal block JP15 at the bottom of the system motherboard is the Sensor Inputs. These are activated by a short to "Common".

Sensor Connections:

JP15 Terminal	Function
1	"Common"
2	"Spare #1"
3	"Common"
4	"Intrusion"
5	"Common"
6	"Solar"
7	"Common"
8	"AC Power"
9	"Common"
10	"600 PTT"
11	"Common"
12	"Spare #2"

Isolated Supply used to power External Sensors

JP16 Terminal	Function
1	"Isolated Supply (Ground)"
2	"Isolated Supply (+5V)"

Sensor Power

Intrusion: Alerts the controller when one of the unit's doors has been opened. Low is intrusion pass

Solar: Used to sense operation of solar power system.

Jumper JP15: pins 5 to 6 and to enable solar sensing. Solar mode latches power sense to prevent low light conditions from causing failures. For solar panel test, initiate a reset, and then a poll. Immediate good power input required after a reset to pass. Jumper JP15 pins 7 to 8 AC sense is required if solar only unit.

Spare 1 & 2: Unused inputs for special functions.

AC Power: Alerts the controller when the AC Power has failed. Open is fail. Closed is pass.

600 Ohm PTT: Puts the unit in Local PA mode for input of external audio. Closed is active.

3.8 Spare Sensor Inputs

The inputs at JP17 are not used in typical applications with the UVIC controller.

3.9 Two-Way Status Monitoring

The UVIC uses a variety of sensors in the UVIC Series Controller, which when equipped with a two-way radio, allows the remote unit to communicate its status back to the base station. This reduces station downtime by quickly alerting operating personnel to potential problems at remote units.

The package itself consist of sensors to provide information on the following conditions:

1. AC Power
2. Battery Voltage (built in)
3. Charger Operation (built in)
4. Activation Current (built in)
5. Signal A (built in)
6. Signal B (built in)
7. Quiet Test (amplifiers and drivers built in)
8. Intrusion

All sensors are optically coupled to provide protection in electrical interface conditions. Consult the Two-Way System supplement or Federal Warning Systems Engineering for further information.

3.10 Quiet Test

This option enables acoustically quiet tests to be performed on the siren control and siren speaker array. Quiet Test uses a 20 kHz tone to quietly test the tone generators, amplifiers, and speaker drivers. To perform this test the Quiet Test must be programmed under one of the activation codes. If it is one of the first 7 codes then it can be activated manually through the switches on the front panel or with the remote activation inputs. Normally once the Quiet Test is programmed under one of the activation codes, the code is activated over the radio channel, the panel switches, or with a local laptop computer running SFCDWARE.

A. Operation

The results of a Quiet Test can be obtained remotely using the SS2000 printout or the SFCDWARE control and status monitoring software. The status can also be obtained locally at the siren site with a portable computer running SFCDWARE. The actual amplifier voltage and current are monitored with Quiet Test providing a true indication of each amplifier and load performance.

B. Finding Faults

When using SFCDWARE, the controller will automatically update the Quiet Test status each time a new Quiet Test is run. The status can be obtained from the status detail screen and from the Reports menu.

3.11 Battery Charger

The battery charger is a smart charger that monitors battery conditions, temperature, and varies charge rate. It is a two-stage charger, charging each

12VDC stage separately. Each stage can consist of more than one battery in parallel. See “Specifications Section,” “Battery,” for required quantity of batteries. The two stages of batteries add up in series to give the 24VDC required for controller operation.

Charger	Description	Connection
Black wire	Ground	To 1 st battery (-)
Red wire 12VDC	12VDC charge 1 st battery	To 1 st battery (+)
Red wire 24VDC	24VDC charge 2nd battery	To 2nd battery (+)
Side terminal back- white wire	Charger sense output- switched voltage driven from charger voltage input	To JP20-2
Side terminal front- red wire	Charger voltage input-voltage to drive Charger sense output	To JP13, 24VDC

Battery Charger Status – Charger Status is indicated by the LED's on the front of the chargers. The left, 1st pair of LED's are for battery 1 and the 2nd pair of LEDs are for battery 2.

Battery Status is as follows:

- Red OFF, Green OFF = Charger OFF
- Red ON, Green OFF = Charging, below 13VDC
- Red ON, Green ON = Charging, above 13VDC
- Red OFF, Green ON = Float charging, battery >90% charged or battery is disconnected from charger.

Note: Battery voltage will be slightly higher when the temperature is below 72°F and voltage will be slightly lower when the temperature is above 72°F.

3.12 UVLOC

All potential users should be properly trained on the use of the control panel.

When the UVLOC is properly connected to the UVIC, the green power LED will be lit. To use the panel, the UVLOC must first be "ARMED" by pressing the ARM button for 1 second. When the UVIC detects that the ARM button has been pressed, the red ARM LED on the panel will light indicating the panel is ready to be operated. When the UVLOC Arm button is pressed, an alarm will be automatically sent to the control system indicating use of the control panel. If no function is activated, the panel will be automatically Disarmed after 30 seconds. If a function is activated, the panel will remain Armed for the duration of the function or until Disarmed. The panel will also be Armed when any other control point Arms the UVIC.

Once Armed, the user must then select the desired function to operate by turning the rotary function selection switch to the desired position. The user must then press the ACTIVATE button for 1 second to operate the function selected.

If LIVE P.A. or RECORD is selected, the user must hold down the ACTIVATE button for the duration of the live message or for the duration of the recording while speaking in a clear voice and talking slowly within 12" of the microphone on the control panel. When the ACTIVATE button is released, the microphone will be disconnected and the function will stop until the ACTIVATE button is pressed again. RECORD will

re-record the previous message each time the ACTIVATE button is pressed. Up to 2 minutes of recording time is available for the record function. The PLAYREC function will play-back the digitally recorded message.

The CANCEL/DISARM button will stop any function in progress and disarm the control panel(s) which will also turn off the Arm LED on the control panel(s).

A function description area is reserved on the bottom of the UVLOC panel to place a label describing each of the functions available with a meaningful description.

SECTION IV

4. SYSTEM PLANNING

4.1 Control Unit

The information in this section provides the user with guidelines necessary for installation.

Control Unit mounting location must first be considered. The Control Unit NEMA Type 1 cabinet must be mounted indoors away from moisture and heavy dust or contaminants. The controller contains batteries, therefore the selected area must have adequate ventilation to prevent accumulation of explosive gas from the batteries.

A light duty lockable hasp secures entry to the cabinet. If additional security is desired, the cabinet should be placed behind a locked door.

The cabinet is suitable for wall mounting with mounting slots on 12" to 16" centers. The total weights of the Control assembly, including user provided batteries, are listed in the specification section. Insure that the mounting surface and fasteners can safely sustain the weight of the assembly.

The Control system requires a 120VAC or 240VAC 50-60 Hz power source (model dependent).

Several methods can be used to activate the Control Unit. The Manual activation switches and a handheld microphone can be used to activate the Control Unit

locally. Landline control can be used through normally open contact switches. Connections should be made directly to the motherboard terminal blocks. The control can also be remotely activated via the optional radio receiver or an external 600 ohm audio source.

If radio control is going to be used, consider RF coverage and antenna placement when selecting a suitable location.

4.2 Speaker Placement

WARNING

The sound output of speakers is capable of causing permanent hearing damage.

Ensure people are not exposed to sounds exceeding 120 dB. Post warnings where applicable.

As a general rule, the warning signal SPL should be at least 10dB above the ambient sound level to ensure it will be heard. Speaker fidelity and placement will also affect voice intelligibility.

Many factors affect the propagation of sound through barriers, over various types of materials, terrain, and changing weather conditions. Consult FEMA CPG1-17, CPG1-14 and your local Federal Signal representative for

assistance to properly place your warning equipment.

The speakers connected to the UVIC may be selectively turned on using amplifier zones. Up to two zones may be programmed into the UVIC to allow Zone 1, Zone 2 or all amp zones to be activated. Amp Zones are programmed using the AZ commands in SFCDWARE.

4.3 UVLOC Placement

The UVLOC should be mounted in an area that is readily accessible by all potential operators. The console should be clearly marked to identify its location.

Up to 10 Local Operation Consoles may connect to each UVIC. The consoles may be placed up to ½ mile away from the UVIC. The console should be wall mounted approximately 5' above the ground. The UVLOC should also be mounted as far as possible from the speaker locations to reduce the potential for audio feedback during a live P.A. announcement.

The UVLOC requires a CAT5 cable run between the UVIC and the UVLOC. An electrical back box is provided for mounting the UVLOC either on or recessed within a wall. Six RJ45 connectors are provided on the UVLOC interface board for making connections. A terminal strip is also provided that accepts bare wire.

SECTION V

5. INSTALLATION

WARNING
Read all Safety Notices at the beginning of this manual before installation.

This section contains reference drawings to assist with installation. A list of typical installation materials required may be obtained by reviewing the

cabinet mounting details in section 5.3 and the electrical installation material list in section 5.4.

5.1 UVIC Siren Controller Installation Reference Drawings

Refer to Figures 5.1, 5.2, 5.3, 5.4 and 5.5 below for reference.

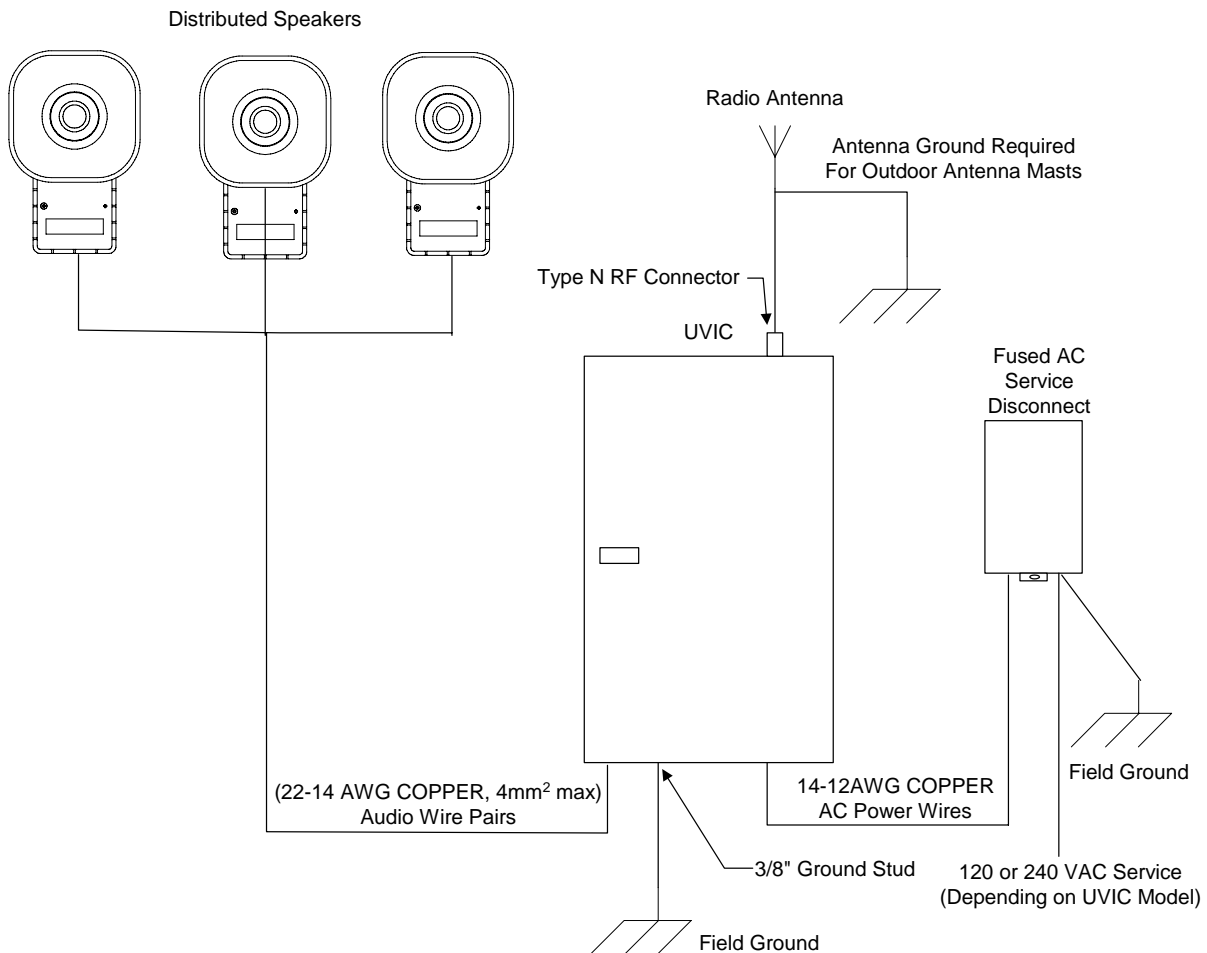

Figure 5.1 - Typical UVIC Installation Drawing

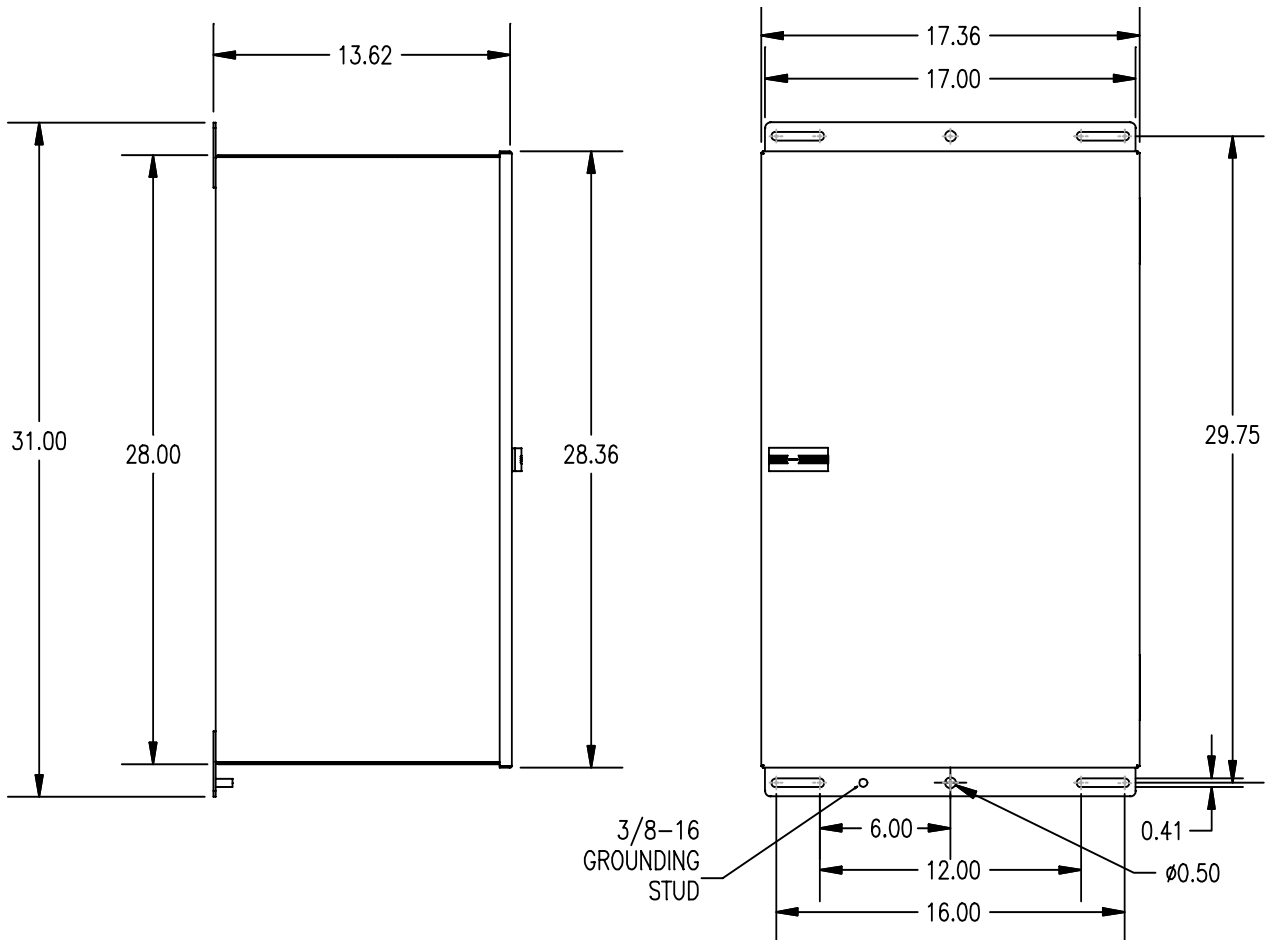
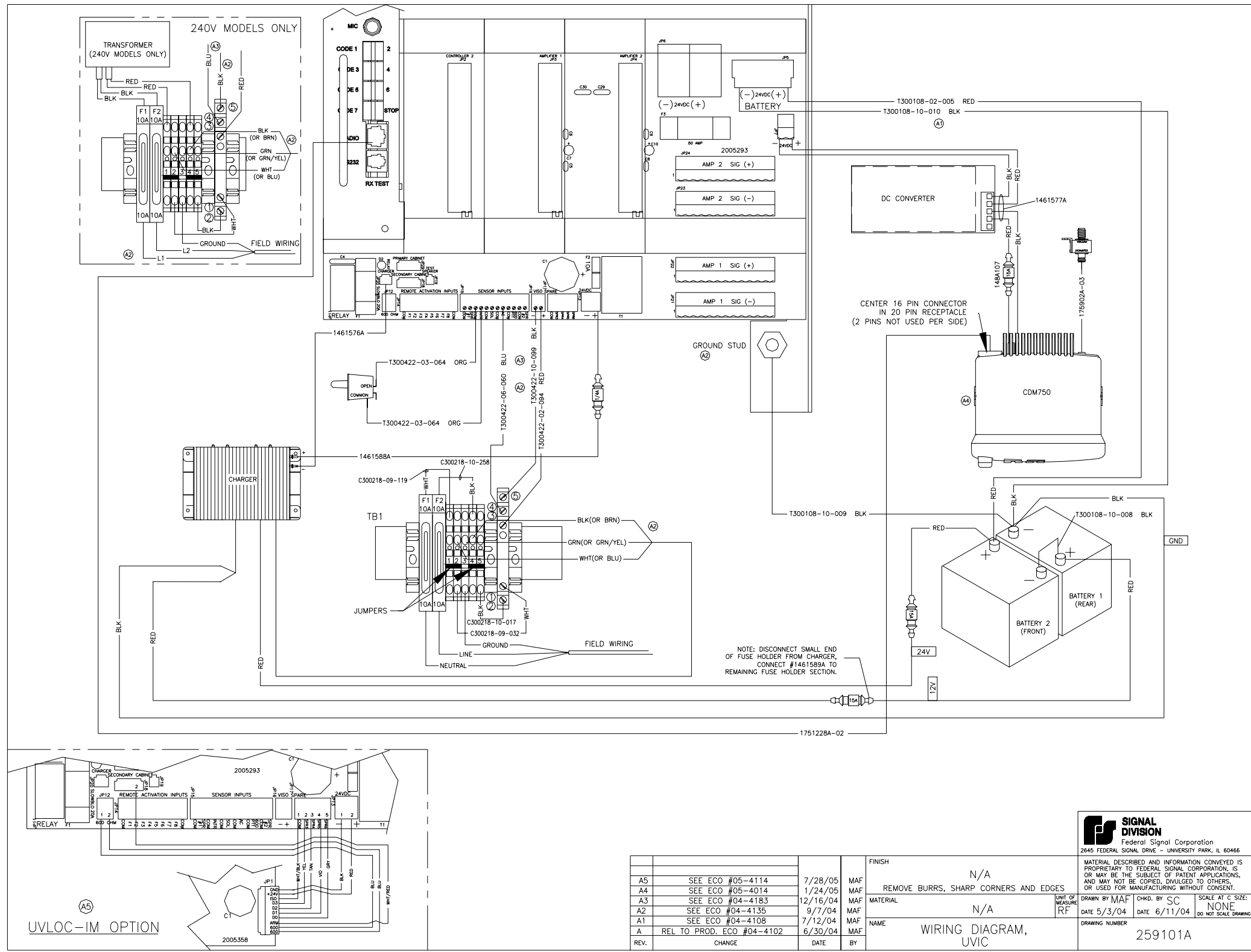

Figure 5.2 - UVIC Cabinet Dimensional Outline Drawing



REV.	CHANGE	DATE	BY	FINISH	MATERIAL	UNIT OF MEASURE	DRAWN BY	CHKD. BY	DATE	SCALE	AT C SIZE	
A5	SEE ECO #05-4114	7/28/05	MAF	N/A								
A4	SEE ECO #05-4014	1/24/05	MAF	REMOVE BURRS, SHARP CORNERS AND EDGES								
A3	SEE ECO #04-4183	12/16/04	MAF									
A2	SEE ECO #04-4135	9/7/04	MAF									
A1	SEE ECO #04-4108	7/12/04	MAF									
A	REL TO PROD. ECO #04-4102	6/30/04	MAF									
				WIRING DIAGRAM, UVIC			DRAWN BY MAF		CHKD. BY SC	DATE 5/3/04	DATE 6/11/04	SCALE AT C SIZE: NONE
							DRAWING NUMBER		259101A			

SIGNAL DIVISION
Federal Signal Corporation
2645 FEDERAL SIGNAL DRIVE - UNIVERSITY PARK, IL 60466

Figure 5.3 – UVIC Wiring Diagram
INSTALLATION
50

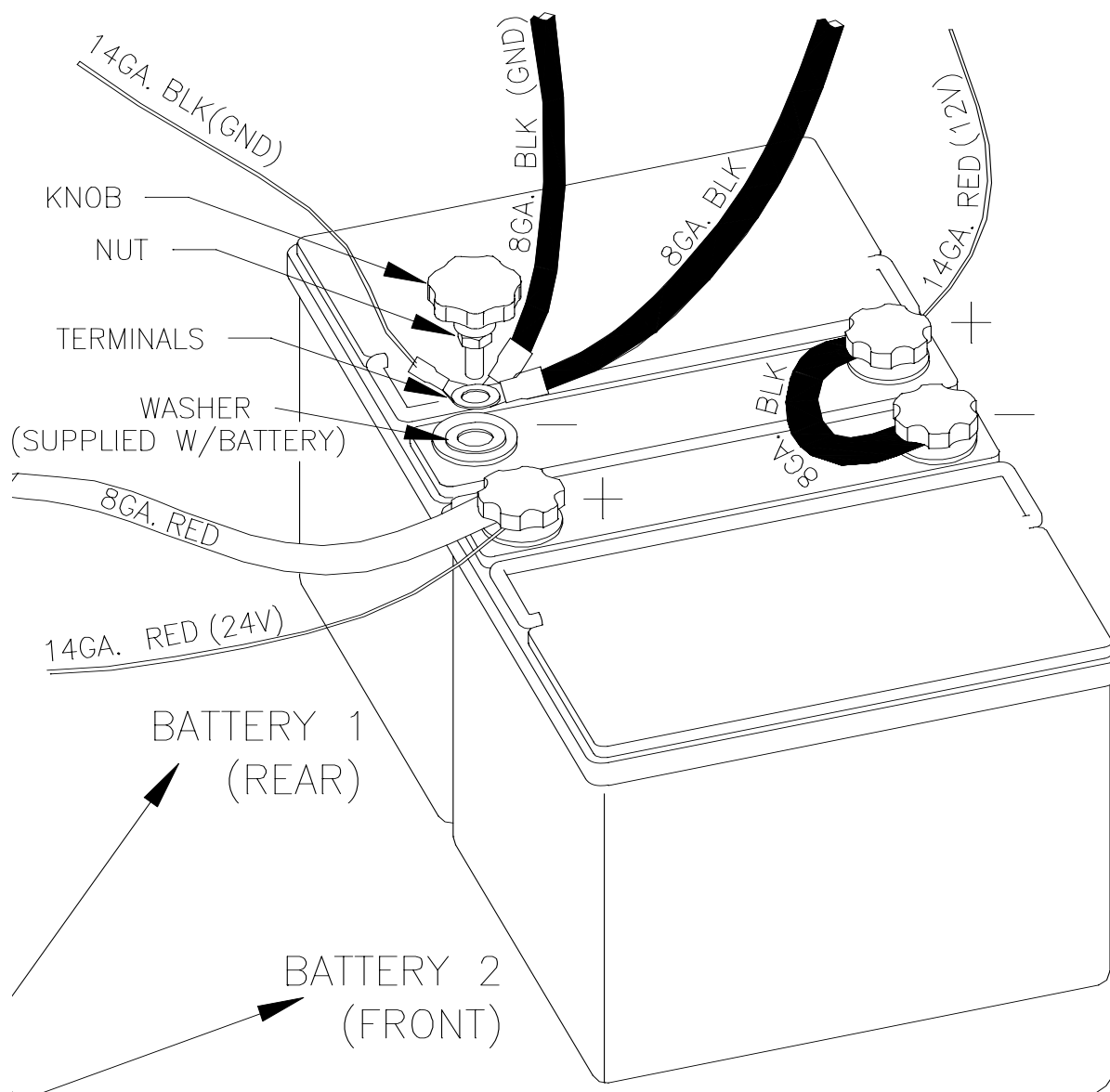

Figure 5.4 – UVIC Battery Connections

5.2 General Mounting Guidelines For All Applications

These general installation instructions are pertinent to all installations. Specific mounting methods and required installation materials are described in the next section.

1. There are three pre-drilled holes in each of the cabinet mounting flanges, (see [Figure 5.2](#)). Depending on the mounting surface, the cabinet may be mounted using either of the following sets of holes:
 - (2) Centered 0.41" mounting holes
 - (4) Mounting slots 0.41" x 2" with 12" to 16" centers.
2. The total weight of the UVIC Cabinet with batteries is listed in the specifications section. It is imperative that the mounting surface and mounting method selected can safely sustain the weight of the assembly. To reduce the weight of the cabinet during installation, do not install the batteries before mounting the cabinet.
3. Prepare the mounting surface for hanging the cabinet by predetermining the location of the mounting holes. The cabinet should be attached to a wall or other substantial vertical surface using the four 0.41" mounting slots. Alternatively, the two-center mounting holes may be utilized alone, if securely lagging directly into a wood stud or other vertical surface capable of handling the weight load.

If the mounting surface is not flat, the cabinet may require shimming to keep the cabinet square.
4. Guidelines for various attachment methods to accommodate different wall types are described in the following section. Provisions should be made for spacing behind the cabinet when mounting to an exterior wall that is susceptible to condensation or other surface moisture.
5. With the two batteries removed, use two people to lift the cabinet to the desired mounting height and lag to the wall using the prepared holes and anchors.
6. After the cabinet is securely mounted, remove any debris that may have entered the cabinet. Remove the two battery hold-down brackets on the bottom right side of the enclosure. Install the batteries oriented as shown in [Figure 5.4](#) but do not connect any wires to the batteries. Re-install the battery hold-down brackets over the batteries.
7. If the UVIC model being installed has a 2-way radio, ensure the radio power switch is turned off until all wiring is completed to avoid damaging the radio.

5.3 UVIC Installation Material List and Installation Guidelines

The following material lists and guidelines describe basic installation details required to install the UVIC cabinet. This list will vary depending on

mounting methods, other options, local and national electrical codes, etc. Therefore, this list should be used as a reference guideline only.

Concrete or Filled Cement Block Wall Mounting Materials		
Material Description	Purpose	Qty
3/8" x 3" Pin/Sleeve/ Lock Washer/ Nut Style Anchors	Anchor Bolts	4

Concrete or Filled Cement Block Wall Mounting Guidelines:

1. Mark the mounting hole locations on the wall for the cabinet.
2. Install the anchor bolts for the four cabinet corners according to the manufacturer's instructions.
3. Mount the cabinet to the wall.
4. Proceed to following section.
Note: If wall is not straight, use shims to insure enclosure maintains square and structural integrity.

Hollow Block Wall Mounting Materials		
Material Description	Purpose	Qty
3/8" x 4" Heavy Duty Toggle Bolts	Anchor Bolts	4

Hollow Block Wall Mounting Guidelines:

1. Mark the mounting hole locations on the wall for the cabinet.
2. Install the anchor bolts for the four cabinet corners according to the manufacturer's instructions.
3. Mount the cabinet to the wall.
4. Proceed to following section.

Wood Stud Wall Mounting Materials		
Material Description	Purpose	Qty
3/8" x 3" Lag bolts	Backboard & cabinet mounting bolts	8
24" x 36" x 3/4" B/C or better plywood	Mounting backboard	1
Construction adhesive	Mounting backboard attachment	1

Wood Stud Wall Mounting Guidelines:

1. Locate the wall studs for attaching the mounting backboard to the wall. The backboard should attach to at least two studs.
2. Mark the wall stud location on the mounting backboard and drill four pilot holes for the 3/8" lag bolts.
3. Apply construction adhesive to the back of the mounting backboard.
4. Attach the mounting backboard to the wall with four 3/8" x 3" lag bolts.
5. Locate the mounting position of the cabinet on the mounting backboard.
6. Drill pilot holes for the 3/8" x 3" lag bolts.
7. Mount the cabinet to the mounting backboard.
8. Proceed to the following section.

Metal Stud Wall Mounting Materials		
Material Description	Purpose	Qty
3/8" x 3" lag bolts	Cabinet mounting bolts	4
24" x 32" x 3/4" B/C or better plywood	Mounting backboard	1
#10 x 3" metal stud screws	Backboard mounting	12
Construction adhesive	Backboard mounting	1

Metal Stud Wall Mounting Guidelines:

1. Locate the wall studs for attaching the Mounting Backboard to the wall.
2. Mark the wall stud location on the mounting backboard and drill pilot holes for the #10 x 3" metal stud screws. Six screws should be placed in each stud evenly spaced apart.
3. Apply construction adhesive to the back of the mounting backboard.
4. Attach the mounting backboard to the wall with #10 x 3" metal stud screws.
5. Locate the mounting position of the cabinet on the mounting backboard.
6. Drill pilot holes for the 3/8" x 3" lag bolts.
7. Mount the cabinet to the mounting backboard.
8. Proceed to the following section.

5.4 Installer Supplied UVIC Electrical Installation Material List

Material Description	Purpose	Qty
30 amp/250V/ 2 Pole Solid Neutral/Fused Disconnect w/ Ground Kit/ NEMA 1 Rating/ Lockable Cover Tang/ Lockable Operator	Optional Electrical Disconnect	1
15A FRNR Fuse	Fuses For 120V Service	1
10A FRNR Fuse	Fuses For 240V Service	2
12-14 AWG White Wire	AC Neutral from disconnect	8'
12 –14 AWG Black Wire	AC Load from disconnect	8'
12 –14 AWG Green Wire	Equipment ground from disconnect	8'
½” Seal Tight Conduit & Fittings	Electrical conduit from disconnect	5”
Metal Ground Bushings	Equipment ground connections	2
Screws, appropriate to mounting surface	Disconnect mounting	4
15A Breaker	Service panel breaker serving unit	1
White Wire appropriately sized	AC neutral from breaker panel to disconnect	Varies
Black Wire appropriately sized	AC load from breaker panel to disconnect	Varies
Green Wire appropriately sized	Equipment ground from breaker panel to disconnect	Varies
Conduit & fittings, appropriately type and size for particular installation requirements	Electrical conduit from breaker panel to disconnect	Varies
#6 Stranded	Cabinet ground to earth ground for external antenna applications	Varies

5.5 Electrical Connections

Install the siren electrical system in compliance with local electrical codes and NEC recommendations. Federal Signal recommends that all user-installed conduit connections enter from the bottom of the UVIC cabinet using the supplied conduit knockouts. Disconnect all power and read all warnings at the beginning of this manual and on the batteries before making connections.

Grounding Requirements

1. The UVIC cabinet must be properly connected to an earth ground. The cabinet contains an external 3/8" ground stud for making this connection. Alternatively, a DIN mounted grounding block is provided inside the UVIC enclosure.
2. If an outdoor antenna is used, a separate antenna ground must be installed.

Externally installed antennas require a dedicated ground to either a ground rod or building steel *below* grade in addition to the UVIC cabinet ground.

AC Power Connections

Caution

Verify the AC voltage requirement for the UVIC model being installed. 240VAC versions of the UVIC controllers have a "240" suffix in the model number shown on the label located on the cabinet door. All other UVIC models are to be wired to 120VAC.

DIN Rail Terminal Blocks

These points provide a convenient location for making electrical connections. A small screwdriver must be pushed into the square opening in the terminal block to open the contact of the block. With the wire inserted, the block will clamp the wire with a spring-loaded connection when the screwdriver is removed from the terminal block.

Each terminal block accepts bare 12-14 AWG wire. The two fused terminal blocks labeled F1 and F2 have a built-in disconnect that flips open, disconnects the circuit, and provides access to the fuse located inside the terminal block.

Wiring Guidelines for 120VAC Electrical Service

1. Install a dedicated 15A breaker in an existing breaker panel or install a new breaker panel if necessary for the UVIC.
2. Install conduit from the breaker panel to a conduit entrance in the bottom of the UVIC.
3. Route user-supplied 12-14 AWG wires (1 black, 1 white, 1 green - optional) through the conduit from the UVIC Cabinet and the fused breaker panel.
4. Connect the white neutral wire from the breaker panel neutral to the fused DIN rail mounted terminal block labeled F1-NEUTRAL in the UVIC control cabinet.
5. Connect the black line wire from the 15A breaker to the DIN rail mounted terminal block labeled F2-Line in the UVIC control cabinet.

6. Optionally, connect a green ground wire from the breaker panel earth ground to the green ground block in the UVIC cabinet or run a ground lead from the external 3/8" ground stud on the UVIC cabinet to earth ground.
7. To avoid shorting the output of the charger, do not apply AC power to the UVIC controller before making the battery connections described later in this section.

Wiring Guidelines for 240VAC Electrical Service

1. Install a dedicated 2-pole 15A breaker in an existing breaker panel or install a new breaker panel if necessary for the UVIC.
2. Install conduit from the breaker panel to a conduit entrance in the bottom of the UVIC. Ensure the conduit is adequately grounded.
3. Route user-supplied 12-14 AWG wires (2 black, 1 green - optional) through the conduit from the UVIC Cabinet and the fused breaker panel (or as otherwise specified by code).
4. Connect one line wire from the 15A breaker panel to the fused DIN rail mounted terminal block labeled F1--L1 in the UVIC control cabinet.
5. Connect the other line wire from the 15A breaker to the DIN rail mounted terminal block labeled F2—L2 in the UVIC control cabinet.
6. Optionally, connect a green ground wire from the breaker panel earth ground to the green ground block in the UVIC

cabinet or run a ground lead from the external 3/8" ground stud on the UVIC cabinet to earth ground.

7. To avoid shorting the output of the charger, do not apply AC power to the UVIC controller before making the battery connections described later in this section.

Battery Connections

DANGER

When installing or removing batteries, take care to avoid shorting battery terminals to metal surfaces. Failure to do so could result in serious personal injury or death. Batteries miss-wired can cause serious personal injury or death. Read and understand the following information before making actual connections.

1. The battery disconnect plug is located behind the cover plate on the right side of the amplifiers. The battery cable is disconnected from the motherboard by grasping the black connector with the large 8 AWG red and black wires and unplugging it from the motherboard.
2. Open the fastener kit provided in the UVIC cabinet containing the plastic battery terminal knobs and spacer nuts. Replace the battery terminal bolts provided with the battery with the terminal knobs and nuts provided in the fastener kit. The kit also contains rubber bumpers that are placed under the battery holding brackets to better secure shorter batteries.
3. Connect the wires to the batteries as shown in [Figure 5.4](#) connecting the short black 8 AWG wire between

batteries 1 & 2 last. Use an anti-oxidant to protect the terminals.

4. Verify the battery connections are tightened securely to make proper electrical connections.

5.6 Antenna Types

Determine type of antenna to be installed:

1. Cabinet Mounted Magnetic Base
2. Remote Mounted Magnetic Base
3. Yagi External Antenna Type
4. Omni external antenna Type

5.7 Cabinet Mounted Magnetic Base Antenna Installation

If the UVIC is being installed in a very good RF coverage area, a cabinet mounted magnetic base antenna may be used.

1. Connect the antenna cable to the antenna connector on the top of the UVIC cabinet.
2. Mount the magnetic antenna base on the top of the UVIC cabinet.

5.8 Remote Mounted Magnetic Base Antenna Installation

The remote magnetic base antenna allows for additional antenna height to improve reception.

1. Locate a suitable location for the antenna that is away from any electrical devices, high voltage and computer wiring. The location should be as high as possible and should enable the

antenna mast to be at least 2' away from any grounded metal objects.

2. Mount the antenna to a flat, secure metal structure with at least 225" square area that the magnetic mount will securely stick to.

5.9 Yagi Antenna Installation

Yagi Antenna Pre-Assembly

1. Unpack the antenna and locate the following parts:
 - Boom (1-14" for 5 element model, 7/8" diameter for 3 element model)
 - 3/8 diameter elements
 - (y---3 = 3 elements, y----5 = 5 elements)
 - Gamma match parts bag
 - Mounting bracket parts bag
2. Find the proper element dimension chart for your antenna, within the antenna instructions, and trim each element according to your operating frequency. Use care to trim equal lengths from each end of each element ensuring that the mounting hole is at the center.

Note A: Proper trimming and adjustment is critical to the Voltage standing wave ratio, known as VSWR. (Basic understanding, in laymen's terms, for VSWR- reflected power is bad and decreases forward power). (The life of the radio and transmit capabilities is dependent upon the VSWR being low as possible).

Note B: If two frequencies are being used, then trim the antenna to the transmit frequency of the unit where the antenna will be mounted.

3. Insert the elements into their respective locations through the boom, starting with R1 (the reflective element) in the hole closest to the mounting holes. Then insert Dr, D1 etc., in that order.

Note A: Shortest element is furthest away from the mount and increases in size as it gets closer to the mount.

Note B: Be very careful to line up the holes and not cross thread when securing the elements in the next step. The bolts must tighten all the way down upon the lock washers.

4. Secure the elements with the stainless steel 10-32 hex bolts and #10 lock-washers provided.
5. Locate the connector/brass tube assembly in the gamma match parts bag and insert the assembly first through the connector bracket, then thread the connector into the bracket. Be sure to tighten the connector fully. A drop of Loctite or other threadlock may be used in the threads to eliminate the possibility of the connector loosening.
6. Slide the gamma link onto the driven element and assemble the gamma match as shown in figure 1 or 2. Set dimensions "A" and "B" to those shown in table 1. Setting the match to the dimensions shown for your antenna is a good starting point, which will allow you to quickly line tune later. Complete the assembly by attaching the end cap onto the end of the gamma tube. The antenna is now ready for final tuning.

Final VSWR Tuning

1. Before final installation of the antenna, temporarily set it up in a clear area at least six feet above the ground.

Caution

Antennas may cause severe burns. Do not touch the antenna while the radio is transmitting.

Note: Ensure antenna is not touching any conductive material and is pointed away from all objects and people. Pointing antenna at objects in close proximity may act as a reflector and create inaccurate readings.

2. Apply RF power to the antenna at the transmit frequency to be used at that antenna, and check for the low VSWR while performing each of the following steps.
 - A. First, loosen the setscrew with the allen key provided and make a slight adjustment to the aluminum gamma tube for the lowest VSWR (Reflected power).
 - B. Next adjust the gamma link along the driven element for the lowest VSWR.
 - C. Repeat the above steps until the lowest VSWR is achieved. Reflected power must be less than 10% of the forward power.
 - D. Return to the dimensions shown in table 1 if there is any trouble achieving a good match. If the element dimensions are incorrect for the frequency being used, low VSWR may be unattainable. If the VSWR specification is still unattainable, replace the cable (a simple ohm meter check of the cable does not guarantee that the antenna cable is

good, due to the DMM not having the ability to check the cable at high frequencies. If that does not take care of the problem, replace the antenna.

Yagi Antenna Mounting

1. See Figure 5.5 for reference. Install antenna, (using installation bracket or equivalent) as high as possible, that the antenna cable and obstacles will allow, and install on side of mounting structure closest to the receiving station. Aim the antenna directly at the receiving station antenna.

Note A: Objects around the antenna will affect antenna performance. Keep the antenna pointed away from obstructions.

2. Ensure antenna cable connections are tight. Seal all connection points with heat shrink or tape and seal with Scotch Coat or equivalent.
3. Apply RF power to the antenna at the transmit frequency to be used at that antenna, and check the VSWR (reflected power). Reflected power must be less than 10% of the forward power.
4. If the VSWR specification is unattainable, replace the cable (a simple ohm meter check of the cable does not guarantee that the antenna cable is good, due to the DMM not having the ability to check the cable at high

frequencies). If that does not take care of the problem, replace the antenna.

5.10 Omni Antenna Installation

Fiberglass, no tune models

1. See Figure 5.6 for reference. Install antenna (using installation bracket or equivalent) as high as possible, that the antenna cable and obstacles will allow, and install on side of pole closest to the receiving station.

Note A: Objects around the antenna will affect the antenna, keep antenna away from objects.

2. Ensure antenna cable connections are tight. Seal all connection points with heat shrink or tape and seal with Scotch Coat, or equivalent.
3. Apply RF power to the antenna at the transmit frequency to be used at that antenna, and check the VSWR (reflected power). Reflected power must be less than 10% of the forward power.
4. If the VSWR specification is unattainable, replace the cable (a simple ohm meter check of the cable does not guarantee that the antenna cable is good, due to the DMM not having the ability to check the cable at high frequencies). If that does not take care of the problem, replace the antenna.

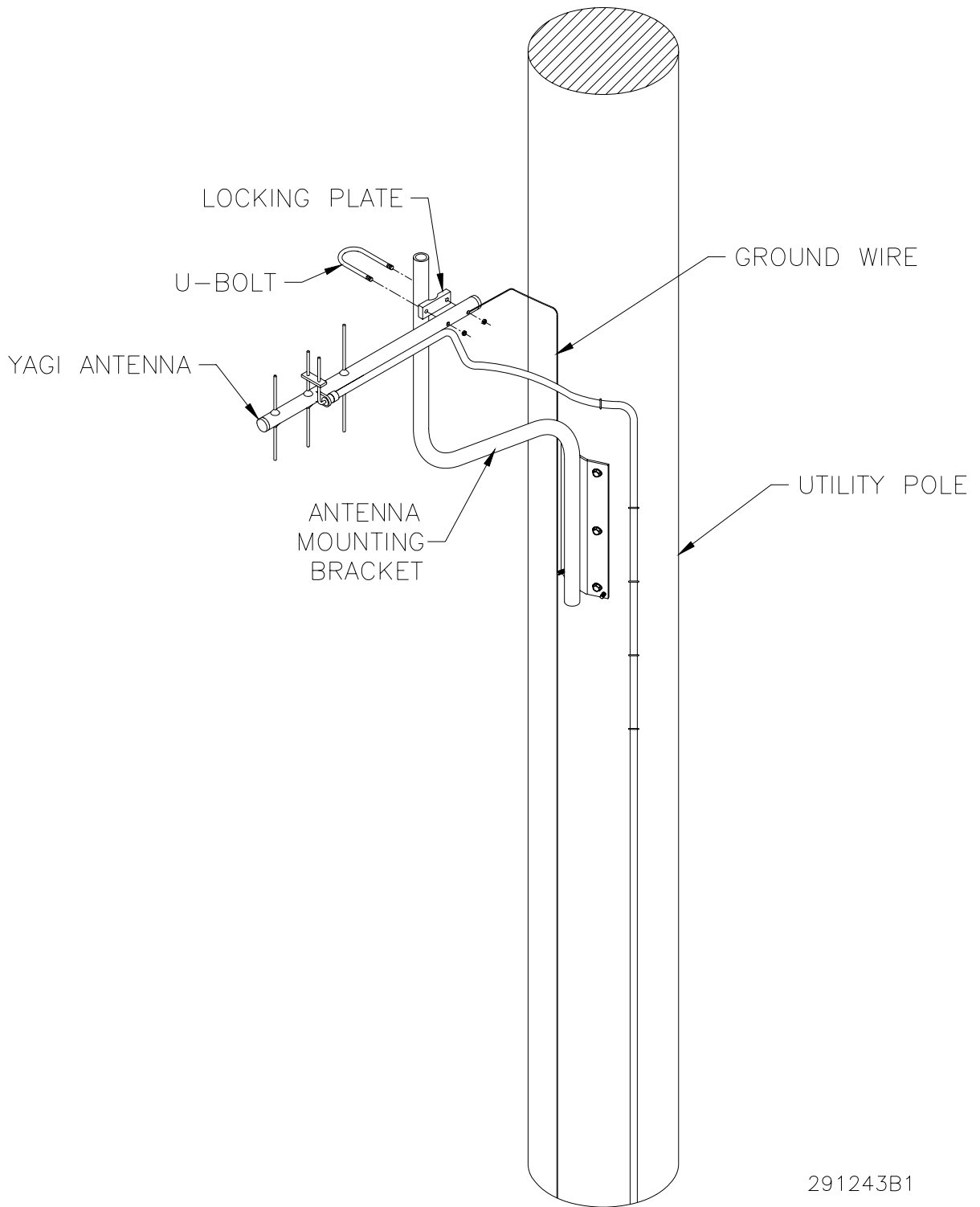

291243B1

Figure 5.5 - Yagi Antenna Installation Example

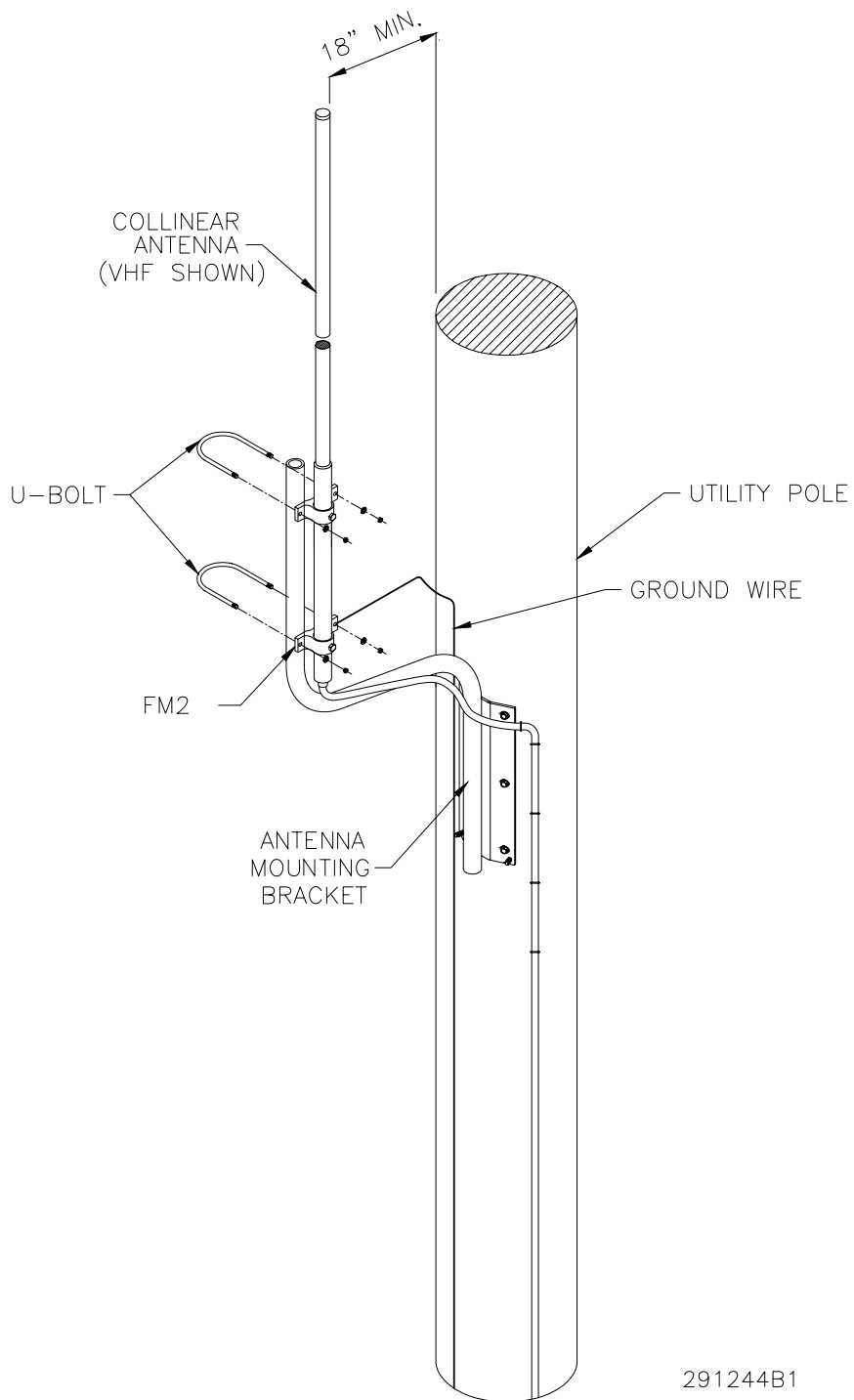
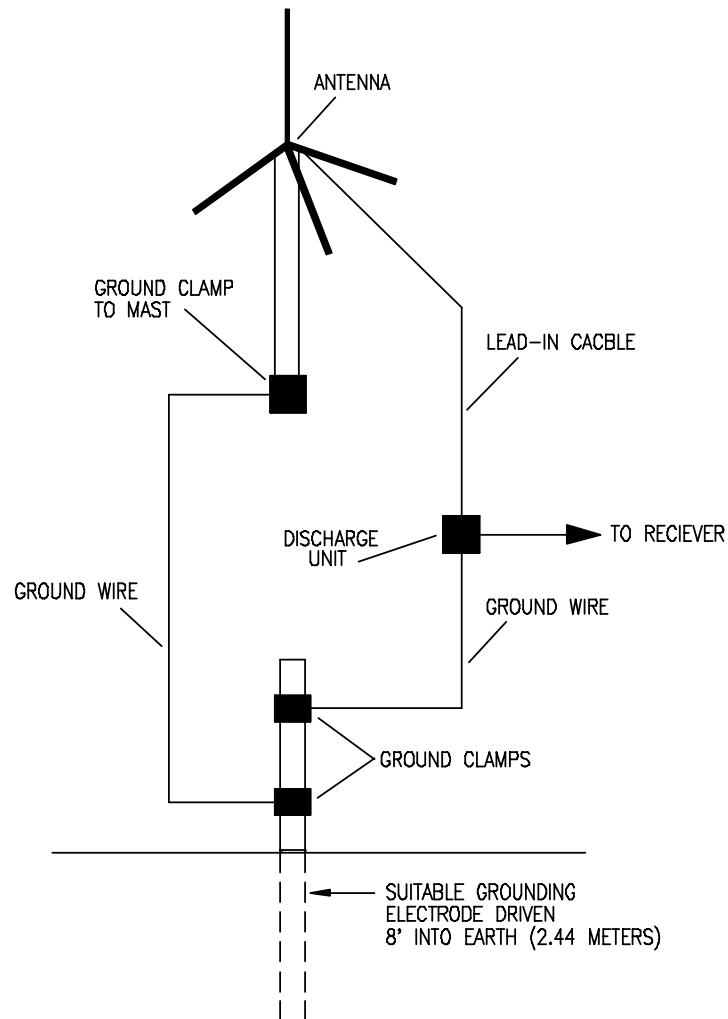

Figure 5.6 - Omni Antenna Installation Example

EXAMPLE OF ANTENNA GROUNDING AS PER
 NATIONAL ELECTRICAL CODE INSTRUCTIONS
 (REFER TO N.E.C. FOR COMPLETE INSTRUCTIONS.)



- A. USE NO. 10 AWG COPPER, NO. 8 AWG ALUMINUM, NO. 17 AWG COPPER CLAD STEEL OR BRONZE WIRE, OR LARGER AS GROUND WIRE FOR BOTH MAST AND LEAD-IN.
- B. SECURE LEAD-IN CABLE FROM ANTENNA TO ANTENNA DISCHARGE UNIT AND MAST GROUND WIRES TO HOUSE WITH STAND-OFF INSULATORS, SPACED FROM 4 FEET (1.22 METERS) TO 6 FEET (1.83 METERS) APART.
- C. MOUNT ANTENNA DISCHARGE UNITS AS CLOSE TO WHERE LEAD-IN CABLE ENTERS HOUSE AS POSSIBLE.

291160

Figure 5.7 – Antenna Grounding Example

5.11 Speaker Connections

The speaker connections are located on the bottom right hand side of the motherboard. There are two 12 position removable connectors for each of the amplifiers enabling up to 12 pairs of wires to be connected to each amp.

The connectors for Amp 1 are located under the card cage. The connectors for Amp 2 are located under the cover plate immediately to the right of the amplifiers.

The output voltage for each of the amps is 70VRMS. Up to 400 Watts of speaker loads may be connected across the 70V line for each amplifier.

If multiple separate speaker wire runs must be used for the installation, an external speaker wire junction box is recommended to be used to simplify field wiring and limit the number of wires in the UVIC cabinet (refer to Figure 5-8).

Consult Federal Signal Customer Support with speaker wiring questions at: 1-800-524-3021.

5.12 PA Audio Connections

The optional remote audio input for Public Address should be connected to the 600 ohm port on the motherboard JP12. For best results, a well-filtered audio source should be used. A contact closure for remote PTT is required at JP15 to enable the 600 ohm input unless a tone encoder is used. The audio cable used should be shielded audio grade cable. The cable length should be kept as short as possible and run away from sources of electrical noise. See the level adjustment procedures in section 6 for this I/O port.

For local PA, plug the provided microphone into the 1/4" jack on the control module. Mount the mic on the mic clip located on the access panel (see Figure 1.1).

5.13 Contact Closure Inputs

Connect any desired remote contact closure inputs to the remote control inputs at JP14 on the Motherboard. Refer to sections 2 & 3 for further information on JP14.

5.14 Optional UVARM Connections

Connections to the UVARM are made on the front of the UVARM card located between the Control module and the Amplifiers. All connections for the UVARM are labeled on the front the card. UVARM wiring should be tie wrapped to the bottom of the card cage assembly and routed through the plastic wiring raceway. Refer to Section 2 for a description of the UVARM connection points and Figure 5-8 for connection details.

5.15 Optional UVLOC Connections and Wall Mounting

Refer to figure 5-9 for the UVLOC mounting hole locations. The UVLOC is typically mounted on a wall approximately 5' above the ground.

The UVLOC requires a CAT5 cable between the UVLOC and the interface board (UVLOC-IM) in the UVIC. One to one connections are made with either the RJ45 terminations or a bare wire terminal block at each end. The interface board connects to the UVIC motherboard using interface cable part number 1461655 as shown in Figure 5-9.

The UVLOC-IM mounting bracket attaches to the left side of the control cabinet using two of the charger mounting studs and the intrusion switch mounting studs. Refer to Figure 9.1 to view the UVLOC-IM bracket and PCB mounting detail.

The UVLOC should be labeled to ensure the operators will know what messages and functions are available. Verify the UVLOC is labeled properly for the application.

5.16 External 24VDC Power Connections

If 24VDC battery power is required to run external devices, the UVIC has a large connector available labeled JP6 (-) 24VDC (+) located behind the cover plate on the right side of the amplifiers. This connector accepts bare stripped wire between 18-6 AWG. A straight blade screwdriver with a 3/32"-1/4" wide tip and a 4.5" max length must be inserted in the connector's square opening to open the round spring loaded wire entry point.

The connector is rated for 50A. The combined load of the UVIC and the external 24VDC load must not exceed 50A. Wire gauge and fusing must be selected appropriately for the load.

5.17 600 Ohm I/O Connections

Control Connections

Terminal block JP12 at the bottom of the system motherboard is used for making connections to 600 ohm balanced audio equipment such as a direct connection to an SS2000D or other type of control and status monitoring equipment. To use the 600 ohm input for control signal audio, a jumper must be placed across pins 2-3 of JP8. JP8 is located on the main controller card. The 600 ohm input can receive audio for control and audio amplification as well as transmit reports to an external unit.

Audio Connections

To use the 600 ohm input for audio from an external audio source, place a jumper across pins 1-2 of JP8. R111 can be used to control the volume level when used in this mode. A contact closure must be provided at JP15 pins 10 and 11 (PTT: Push To Talk)

to turn on the amplifiers and route the 600 ohm audio to the amplifiers. For best results, a well-filtered audio source should be used. The audio cable used should be shielded audio grade cable and the length should be kept as short as possible. Keep away from sources of electrical noise.

5.18 Turning Power On

1. Verify all wiring has been completed in the previous sections and that the connections are tight and secure. After the battery connections and antenna connections have been made and the battery disconnect connector has been plugged in, the UVIC will be running on battery power.
2. The UVIC control board clock LED will begin to blink approximately 30-sec. after power has been applied.
3. Connect AC power and verify that the battery charger LEDs turn on indicating the charger is charging the batteries.
4. Turn on the radio transceiver power (if applicable) and verify the radio power LED turns on.

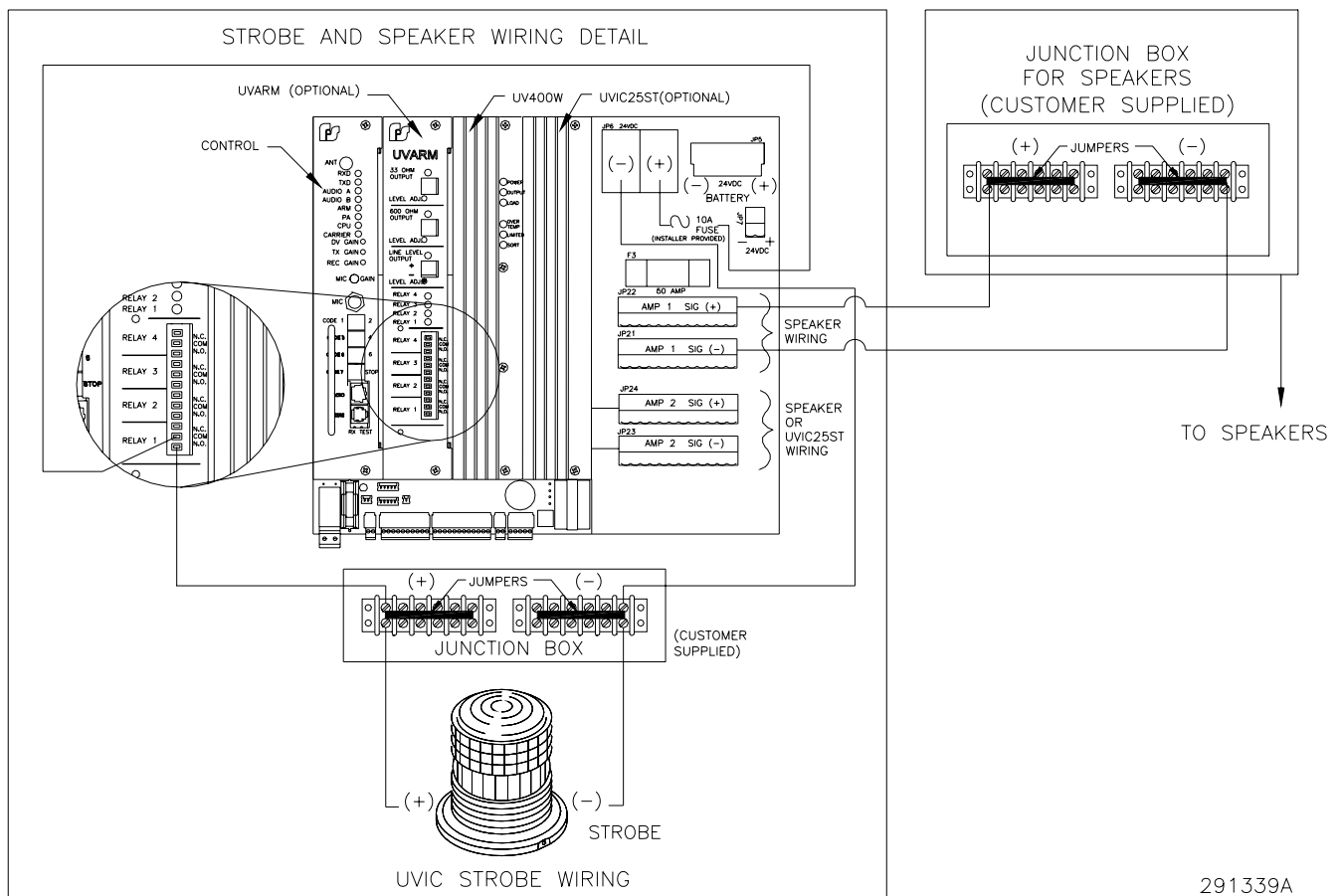

291339A

Figure 5.8 – UVIC Strobe and Speaker Wiring

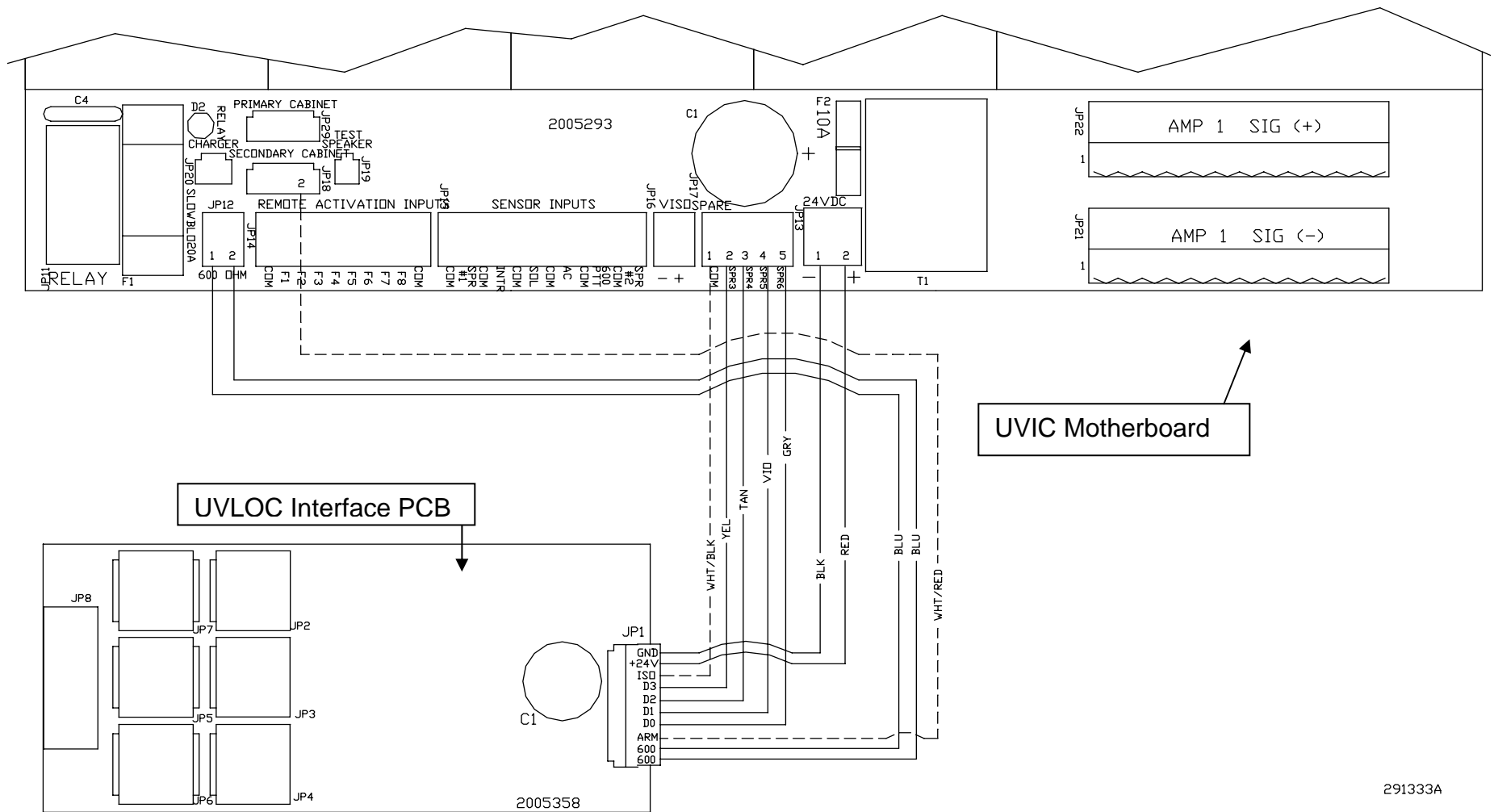

291333A

Figure 5.9 - UVLOC Interface Wiring Diagram

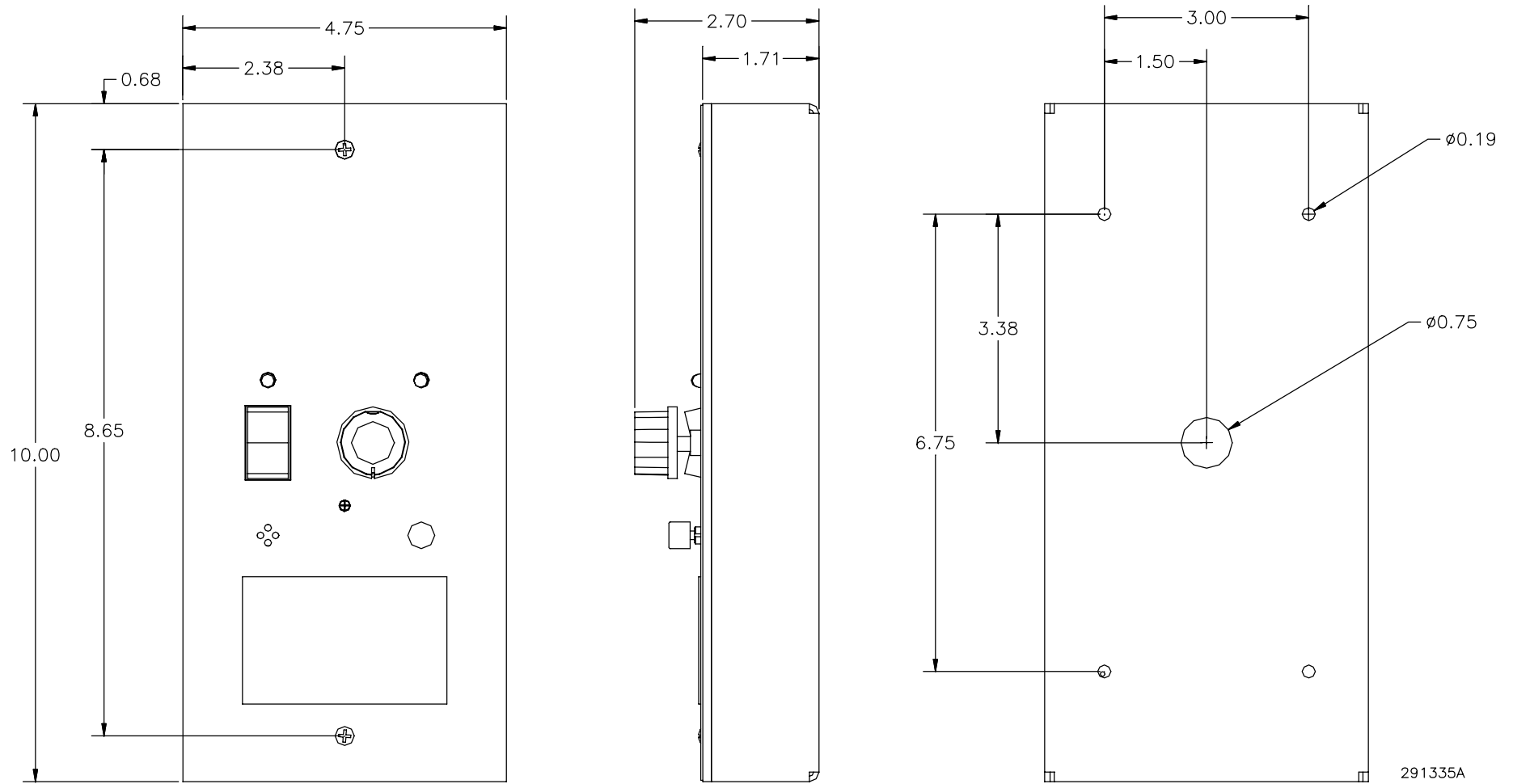
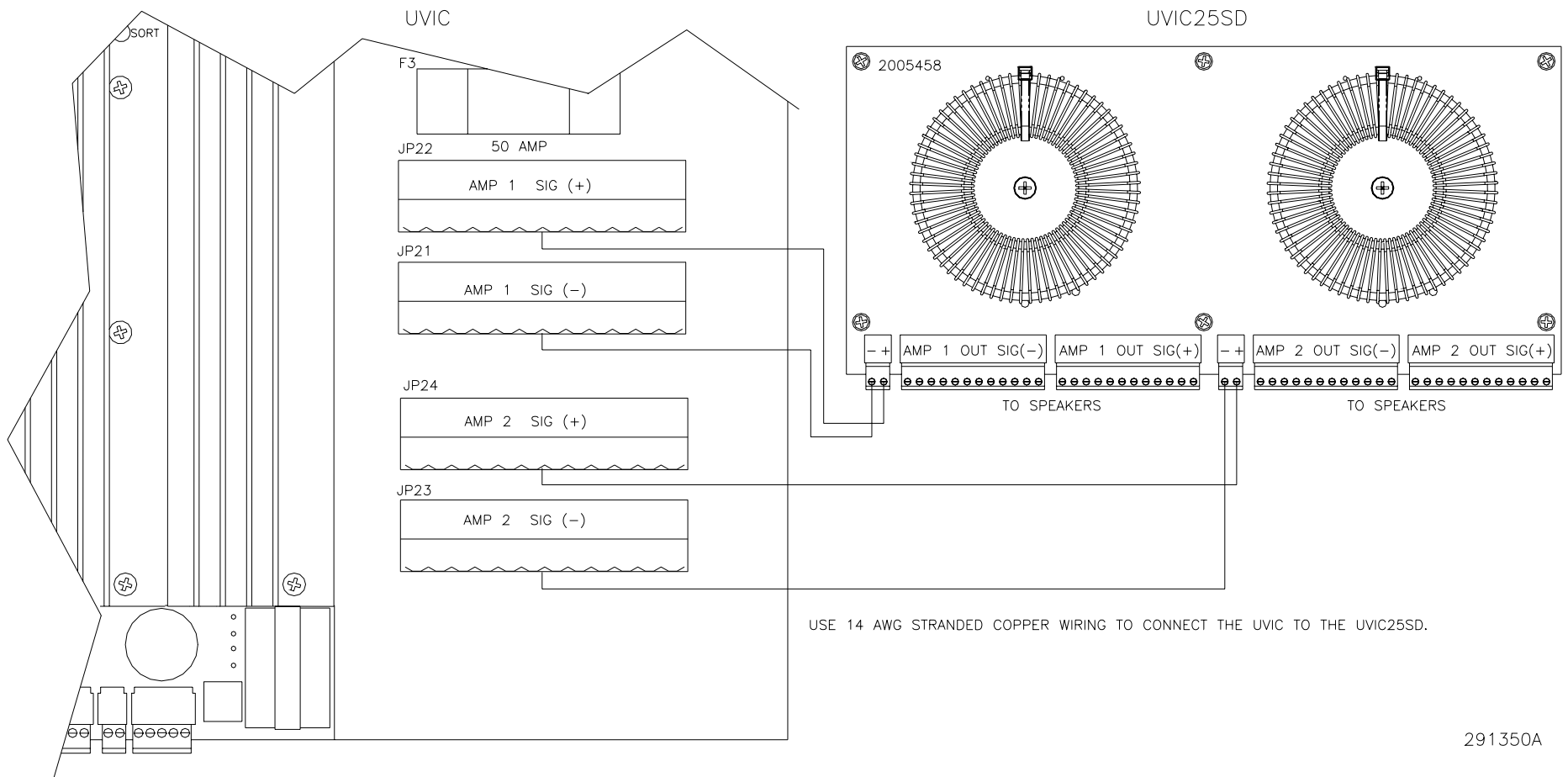

Figure 5.10 - UVLOC Dimensional Outline



291350A

Figure 5.11 – UVIC25SD Field Wiring Diagram

SECTION VI

6. PRE-OPERATION CHECKOUT AND TEST

Warning

The following procedures should be performed by a properly trained technician to ensure the equipment is operating properly.

6.1 Visual Inspection

1. Fill out the Field Test Data Sheet at the end of this section to document the following inspections and tests. The completed document should be kept on file for future reference.
2. Verify all connections and fasteners are tight.
3. Ensure that all installation debris is removed from the cabinet.
4. Secure all wiring with wire-ties to provide strain relief and to neatly manage the wiring.
5. Verify the control board clock LED is blinking.
6. Verify the charger LED(s) are on for the appropriate charging state.

6.2 Amplifier and Speaker Pre-Operation Checkout

1. Refer to Figure 5.4. Measure the DC voltage between battery 1 (-) and battery 2 (+). The voltage should be at least 25VDC. If the voltage is below 25VDC, verify the red "charging" LEDs are on lit on the charger. Allow the batteries time to charge before continuing with the tests.
2. Refer to Figure 6.1. Verify the microphone is plugged into the ¼" jack in the control module. Turn the mic volume potentiometer fully counter clockwise. Press the PTT button on the mic and announce a test message i.e.: ("Testing 1,2,3,4, Testing"). Turn the mic volume knob clockwise until the desired level is obtained during the test count.
3. Verify the Audio A, Audio B, ARM, and PA LEDs on the control and the green LEDs on each amp light when the test message is broadcast.
4. Calibrate the Quiet Test function by pressing switches 2 & 3 on the controller's front panel at the same time.
5. All siren signals should be tested at this time by momentarily depressing the appropriate switch on the control module front panel.

6.3 Radio Transceiver Adjustment Procedure

Note: This procedure previously completed at factory. Only readjust if radio re-alignment is required or if the radio is being installed in the field.

A. Qualifications:

Requires a properly trained Radio Technician.

B. Equipment Required:

1. Service Monitor
2. Oscilloscope

C. Setup:

Connect the radio to the service monitor.

D. Receive Audio Adjustment

1. Using service monitor, modulate the correct RF signal into the receiver with a 1kHz tone at 3kHz deviation. If bandwidth is 12.5, then modulate at 1.5kHz deviation. (If using private line, add 0.75kHz private line deviation to the signal.)

2. Adjust the level at TP10 (2005141 controller card) for $1V_{p-p}$ using the REC gain adjustment R59 (2005141 controller card front panel).

E. Transmit Deviation Adjustment

1. Simultaneously press buttons 5 & 7 on the 2005141 controller card. This will cause the controller to transmit for approximately 8 seconds.

2. Measure the deviation level using service monitor.

3. Adjust the TX level (2005141 controller card front panel) for 3kHz deviation. If the bandwidth is 12.5kHz, then adjust for 1.5kHz deviation (If using private line, add 0.75kHz private line deviation to the signal.)

Note, slightly higher S/N levels can be obtained by increasing the RF modulation levels to 4 and 2kHz depending on the channel spacing. Do not exceed these deviation levels. All sites in the system should be set to the same modulation level.

6.4 600 Ohm Level Adjustment Procedure for Communications

Note: To use the 600 ohm input for receive audio, a jumper must be across pins 2-3 of JP8. JP8 is located internally on the main controller card.

1. RX Adjustment
 - a. Ensure Base Station TX level is adjusted properly. Nominal base station TX level would be $1V_{p-p}$ or approximately 0dB.
 - b. Transmit a tone from the Base Station.
 - c. Ensure tone is not clipped by viewing waveform with an oscilloscope.
 - d. Adjust the level at TP10 (2005141 controller card) for $1V_{p-p}$ using the REC gain adjustment R59 (2005141 controller card front panel).

- e. Ensure tone is not clipped by viewing waveform with an oscilloscope.
2. TX adjustment
 - a. Simultaneously press buttons 5 & 7 on the 2005141 controller card. This will cause the controller to transmit for approximately 8 seconds.
 - b. Determine proper siren TX level required (typically $1V_{p-p}$ or approximately 0dB.)
 - c. The TX levels for all of the siren controllers must be the same.
 - d. Verify the RX audio received at the Base Station is not clipped or distorted by viewing waveform with an oscilloscope.

6.5 600 Ohm Adjustment Procedure for External Audio Source

Note: To use the 600 ohm input for external audio, at JP8 a jumper must be across pins 1-2. JP8 is located internally on the main controller card.

1. Audio source adjustment for external audio source.
 - a. Transmit a tone from the external audio source.
 - b. Ensure tone is not clipped or distorted by viewing waveform with an oscilloscope.
 - c. The nominal external audio source level is $1V_{p-p}$.
 - d. Adjust the external audio source to the appropriate level.
2. Audio source adjustment for UVIC controller.
 - a. Transmit a tone from the external audio source. Note that a contact

closure at JP15 pins 10 and 11 (PTT: Push To Talk) is required to activate audio mode.

- b. Adjust the level using the external audio gain adjustment R111 (R111 located internally on the 2005141 controller card circuit card).
- c. Set for same level as the standard siren sounds.
- d. Ensure that the sound is not distorted.

6.6 Control and Status Monitoring

1. Use The Commander Digital System (SFCDWARE) to verify the UVIC has been properly configured for the application. Make any required changes.
2. The control and status monitoring features should be tested from each control point. Test each control function and all status indications using SFCDWARE. Verify each status point provides the proper indication of both pass and fail conditions.

6.7 Optional UVLOC

After all connections have been made and power is applied to the UVIC, verify the green power LED on the control panel is on. Turn the rotary selection switch fully counter clockwise to the LIVE P.A. position. Press the ARM button for 1 second and verify the red ARM LED turns on. Press and hold the ACTIVATE button while speaking into within 12" of the microphone. Verify the P.A. audio is clear and at the desired

output level. A small straight blade screwdriver can be used to adjust the microphone sensitivity. The nominal level should be set to approximately zero dBm out of the control panel. The speaker level may also be adjusted at the UVIC control board by adjusting R111. R111 should be set to provide 10Vp-p at TP1 on the control board when the UVLOC is putting out 0dBm.

After the levels have been properly adjusted, verify all other functions operate properly from the UVLOC control panel.

The UVLOC should be labeled to ensure the operators will know what messages and functions are available. Verify the UVLOC is labeled properly for the application.

UVIC Field Test Data		
Customer:	Project Number:	Date:
Contact Person:	Phone:	Second Phone:
Radio Shop:	Contact:	Phone:

Siren Type:	S/N:	Voltage:
Controller Type:	Antenna: Omni <input type="checkbox"/> Yagi <input type="checkbox"/> Cabinet Mounted <input type="checkbox"/> External Mounted <input type="checkbox"/>	A/C Service: O.H. <input type="checkbox"/> U.G. <input type="checkbox"/>
CPU Software:	Program file:	SMV:

Radio Information: Low Band <input type="checkbox"/> VHF <input type="checkbox"/> UHF <input type="checkbox"/> 800 <input type="checkbox"/> Trunk <input type="checkbox"/> 12.5 KHz <input type="checkbox"/> 25 KHz <input type="checkbox"/>
Radio Frequency: TX RX PL

Site:	S/N:	Address:	Zone:
A/C voltage: Vac	Battery voltage:	Charger voltage:	

Battery Type:	Model:	Manufacturer:
---------------	--------	---------------

1. Press buttons "2" & "3" on the CPU control board simultaneously. This will calibrate the speakers and amplifiers.
2. Remove audio output lines from Amps 1-2 on the motherboard by pulling the connector out. This will remove the speakers from the circuit.
3. Select and execute the "STEADY" signal. Take RMS readings while unit is performing this function. When done recording readings, cancel the "STEADY" signal.
4. Replace the audio output connections to re-connect the speakers.

RMS VAC	Impedance Ω	Sensor	State
Amp 1 VAC	Amp 1 Ω	Intrusion Sensor	Pass <input type="checkbox"/> Fail <input type="checkbox"/>
Amp 2 VAC	Amp 2 Ω	Low Battery	Pass <input type="checkbox"/> Fail <input type="checkbox"/>
		AC Power On	Pass <input type="checkbox"/> Fail <input type="checkbox"/>
		AC Power Off	Pass <input type="checkbox"/> Fail <input type="checkbox"/>

Mic mounted in Control Cabinet: Yes <input type="checkbox"/> No <input type="checkbox"/>	Debris removed from Control Cabinet: Yes <input type="checkbox"/> No <input type="checkbox"/>
Antenna connectors sealed: Yes <input type="checkbox"/> No <input type="checkbox"/> (Required for outdoor antenna installations)	
Tested by:	Date:

Notes:

Field Test Data Sheet

PRE-OPERATION CHECK-OUT AND TEST

SECTION VII

7. MAINTENANCE

WARNING

Service and maintenance should be performed by qualified personnel familiar with the UVIC, associated controls, and power sources being used and in conjunction with the authorities having jurisdiction.

The sound output of speakers is capable of causing permanent hearing damage. Use adequate hearing protection and avoid excessive exposure.

Before servicing or maintaining, ensure that remote activation cannot occur and disconnect power to the UVIC.

The UVIC series speaker controller is designed to require a minimum amount of maintenance. In addition, experience has shown that all Federal Signal products are highly reliable devices. However, if a failure does occur, Federal will provide technical assistance with problems that cannot be handled satisfactorily and promptly locally. If assistance is desired, contact:

FWS Service Department
Signal Division
Federal Signal Corporation
2645 Federal Signal Drive
University Park, Illinois 60466
(800) 524-3021

WARNING

The sound output of speakers is capable of causing permanent hearing damage at short distances. Therefore, ALWAYS wear hearing protection when performing tests or maintenance on the speakers.

To prevent the speakers from sounding, always turn off the power to the UVIC at the AC disconnect and remove any DC power being supplied before inspecting or maintaining the speakers.

7.1 Control Unit Preventive Maintenance

Test the UVIC for proper operation at least once a month. A daily test at noon, curfew, or other selected time is preferred. This not only enhances the usefulness of the UVIC and verifies that it remains ready for use when needed; it also instills confidence in the reliability of the system.

In order to minimize the potential for a failure, annual inspection and maintenance is recommended.

7.2 General Maintenance

Signal Operational Check

1. When checking for proper control module output, unplug the terminal strip connectors to the speakers (at the bottom of the system

motherboard) to eliminate output from the speaker array.

2. Activate each of the signals and observe the signal indicators on the control module and the amplifiers.
3. If desired, an oscilloscope or digital multi-meter (DMM) can be connected to the amplifier module output terminal strip to observe the amplifier output. This output should be at least 67 Vrms during a signal if the amp is programmed to run at full power. To limit sound output, plug in one amplifier at a time during this test.
4. Plug all of the amplifier terminal strip connectors to enable amplifier outputs.

Battery Check

1. The voltage of a fully charged set of batteries should be approximately 27.2 VDC, and charger current should be less than 2 Amperes. The charger is set for 27.2 +/-0.1 VDC at room temperature.
2. Load test the batteries per the manufacturer's specifications.
3. Maintain or replace the battery as recommended by its manufacturer; obey local or state laws governing the disposal of lead-acid batteries.
4. Check the battery terminals for corrosion. Clean and grease connectors and terminals, if necessary.

7.3 Troubleshooting

	PROBLEM	ACTION
1.	NO RADIO DECODE	A. Unit is not programmed to recognize that particular code sequence (or) Signal is not being received properly. B. Verify programming is correct. Check the received audio signal quality at the RX test pin on the front of the control board.
2.	LOW OUTPUT FROM SPEAKERS	Check battery voltage. Also, check signal indicators on amplifiers during a function. If indicators are off, remove amplifier for service.
3.	FUNCTION STOPS BEFORE NORMAL TIME-OUT	Batteries may require further charging. Check battery voltage under load. Check charger output.
4.	LOCAL PA FEEDS BACK	Lower PA volume using knob above MIC connector.
5.	LOCAL PA HAS LITTLE OR NO OUTPUT	Hold MIC close to mouth. Increase PA volume using knob above MIC connector.
6.	BATTERIES NOT HOLDING CHARGE	Check that charger fuses are intact and check charger output. Test batteries.
7.	RELAY OUTPUT ON MOTHERBOARD DOESN'T OPERATE	Check that the relay on the system motherboard is operating (indicated by LED D2). Also check fuse F1 on motherboard (20 amp slo-blow)
8.	RADIO PA TAKES TOO LONG TO TIME OUT	Check radio for proper operation of squelch. CD LED should light while carrier is present.
9.	LANDLINE ACTIVATION INPUTS DO NOT FUNCTION	Verify minimum 1- second contact closure is applied to JP14 on the motherboard.

NOTE: For additional help contact the FWS Service Dept. at (800) 524-3021.

SECTION VIII

8. OPTIONS

8.1 Radio Control

The UVIC can be activated by a radio signal when the optional radio transceiver is incorporated into the Control Unit. Activation by radio control has the advantage that control lines are not required between the control site and the UVIC. Federal Signal offers the controller with a full line of transceivers built in which cover the VHF and UHF bands.

8.2 Digital Voice Recording

Four minutes of digital voice storage is provided as a standard feature with the UVIC. When the Digital Voice Recording option (model DVR) is purchased, the UVIC will be factory programmed with high quality voice or music recordings as specified by the customer.

Up to 16 individual messages may be programmed into the UVIC. Digital Voice Messages may be activated remotely or via the control panel switches. To program activation codes with Digital Voice Messages under them, follow the instructions in the Commander Digital System manual. It is possible to assign codes to the functions DIG VOICE 1 through DIG VOICE 16. As in all sounding functions, the unit must first be sent the ARM command followed by one of the six DIG VOICE

commands to activate the stored message. The only adjustment available on the Digital Voice PCB is a potentiometer, which adjusts the audio output level.

8.3 UVIC25ST Option

When purchased, the UVIC25ST allows the end-user the capability to reduce audio output from the 70VRMS standard to the 25VRMS standard. This option is beneficial when deploying the UltraVoice electronic controller in an indoor warning application. See Section 9 for wiring details.

8.4 UVIC25SD Option

As with the UVIC25ST, the UVIC25SD allows the end-user the capability to reduce audio output from the 70VRMS standard to the 25VRMS standard. The UVIC25SD consists of a PC board with two 400W step-down transformers housed inside a fiberglass enclosure. This option is needed instead of the UVIC25ST when purchasing two UV400 amplifiers.

8.5 UVARM Option

The Audio and Relay Output module provides three separate audio outputs for the UltraVoice controller to interface with other devices and systems. The outputs consist of a balanced 33 ohm, a balanced 600 ohm, a selectable 600

ohm balanced or single-ended line level output and four SPDT relay outputs. The level of each audio output is independently adjustable. Each audio and relay output is individually addressable allowing each output to be activated at different times.

The UVARM connects to one of the two control card connectors on the UVIC motherboard and is mounted on an aluminum faceplate with mounting holes for attaching to the UVIC card cage. The connectors for the ARO are located on the front of the card and extend through openings in the faceplate. SFCDWARE is used to assign Audio and Relay outputs to functions. Audio and Relay outputs may be selectively programmed to be active together or individually with any control function. The outputs may be programmed to stay on for the duration of the function, or latch on until turned off.

8.6 UVLOC Option

An optional Local Operation Console (model UVLOC) enables users to control the UVIC from an easy to use pushbutton control panel. The panel is connected to the UVIC with a standard CAT5 network cable and may be located up to ½ mile away from the UVIC controller. The UVLOC is remotely powered from the UVIC and requires no local power source of it's own. The panel measures only 10" x 4.75" x 3" (L x W x D) and is easily wall mounted. The UVLOC provides control for 7 digital recordings: Live P.A., P.A. Recording from an integrated microphone, Recorded P.A. Playback, and two Auxiliary user programmable functions.

8.7 Installation of User Supplied Radio Receivers

CAUTION

Improper installation of radio control equipment may cause the speakers to malfunction or operate intermittently. Installation must only be performed by experienced radio technicians who have thoroughly read this manual.

1. TUNING - Tune the radio receiver to the manufacturer's specifications.
2. POWER - Determine the radio power requirements. The ULTRAVOICE control panel provides +12VDC on the RADIO connector on the front panel, as shown below;

- RADIO Connector, 8 pin MOD jack;
1. Receive Audio, 150mV – 10V_{p-p}
 2. Transmit Audio, 50mV - 3V_{p-p}
 3. Carrier Detect - active low
 4. PTT
 5. +12VDC
 6. GND
 7. +12VDC
 8. GND

This voltage source must not be used for radios, which draw more than 1.5 Amps of current in transmit. Use both grounds and both +12VDC connections for current handling. If a higher current output is required, a 24VDC - 12VDC voltage converter must be purchased. This converter is provided with the UVIC series models. Do not use one of the 12VDC batteries to run the radio equipment.

1. AUDIO – The ULTRAVOICE controller Receive Audio Input should be connected to the de-emphasized Audio Output of the radio. Use shielded audio grade cable and keep wire runs as short as possible. The Receive Audio level can vary from 150mV – 3V_{p-p} unclipped.
2. The Transmit Audio Output is adjustable from 50mV - 3V_{p-p}.
3. C.D. - The carrier detect signal from the radio must pull to ground when active. The radio carrier detect signal is useful for controlling live PA. When the C.D. signal is removed from the controller for over 5 seconds, the controller will automatically cancel the PA function eliminating the need to broadcast the cancel tones over the speakers.
4. PTT – The PTT output pulls to ground when active to key the radio.
5. RX and TX Audio – Adjust the RX and TX Audio levels as described in section 6.

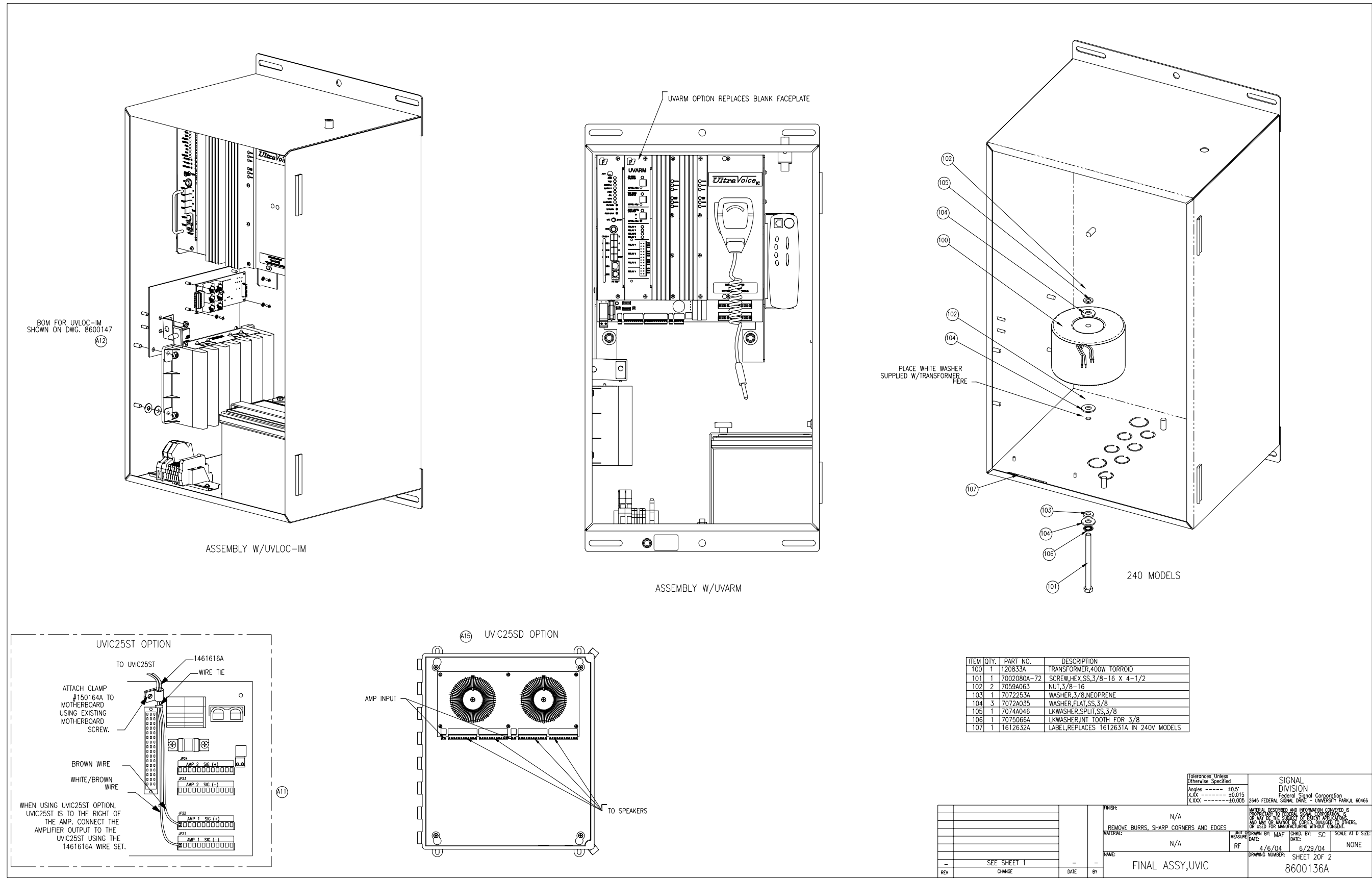

BOM FOR UVLOC-IM
SHOWN ON DWG. 8600147
A12

ASSEMBLY W/UVLOC-IM

UVARM OPTION REPLACES BLANK FACEPLATE

ASSEMBLY W/UVARM

PLACE WHITE WASHER
SUPPLIED W/TRANSFORMER
HERE

240 MODELS

UVIC25ST OPTION

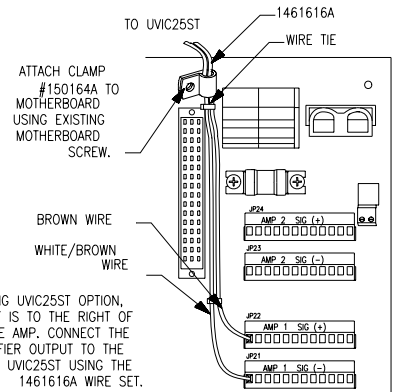

A11

UVIC25SD OPTION

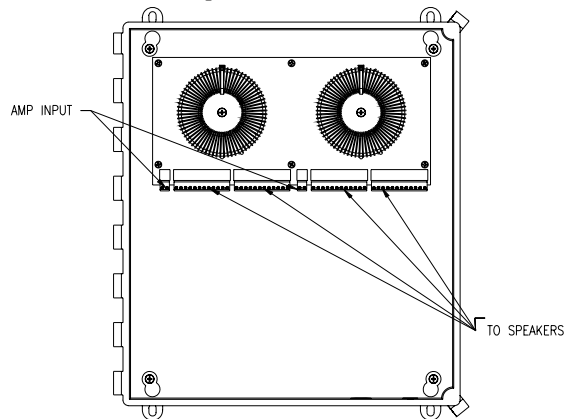

ITEM	QTY.	PART NO.	DESCRIPTION
100	1	120833A	TRANSFORMER,400W TORROID
101	1	7002080A-72	SCREW,HEX,SS,3/8-16 X 4-1/2
102	2	7059A063	NUT,3/8-16
103	1	7072253A	WASHER,3/8,NEOPRENE
104	3	7072A035	WASHER,FLAT,SS,3/8
105	1	7074A046	LKWASHER,SPLIT,SS,3/8
106	1	7075066A	LKWASHER,INT TOOTH FOR 3/8
107	1	1612632A	LABEL,REPLACES 1612631A IN 240V MODELS

Tolerances Unless
Otherwise Specified
Angles ----- ±0.5°
X.XX ----- ±0.015
X.XXX ----- ±0.005
2645 FEDERAL SIGNAL DRIVE - UNIVERSITY PARK,IL 60466
SIGNAL
DIVISION
Federal Signal Corporation

FINISH:	N/A	UNIT MEASURE:	RF	DATE:	4/6/04	SCALE:	AT D SIZE
REMOVE BURRS, SHARP CORNERS AND EDGES		DATE:	6/29/04	SCALE:	NONE		
NAME:	FINAL ASSY,UVIC	DRAWING NUMBER:	8600136A				
REV	CHANGE	DATE	BY				
	SEE SHEET 1						

Figure 9.1 – UVIC Final Assembly and Parts List (Page 2 of 2)

UVIC25ST OPTION

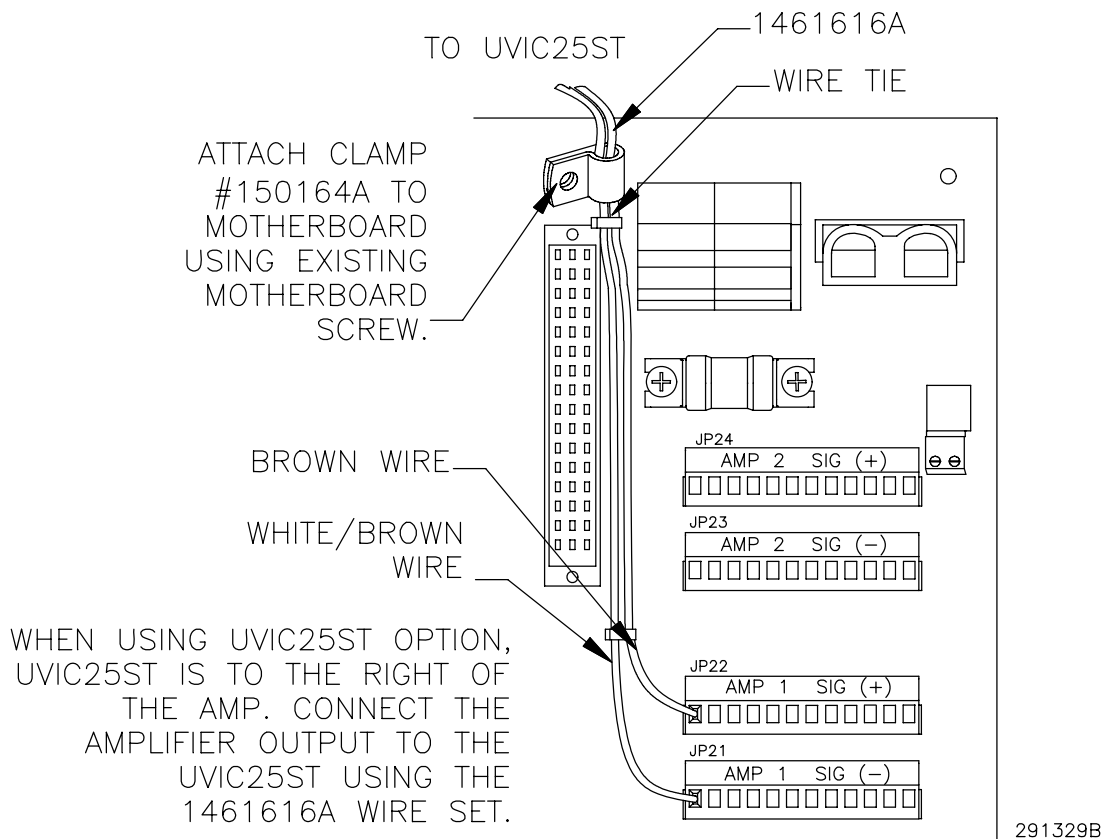

Figure 9.2 – UVIC25ST Wiring Detail