

SS2000 Series

CONTROLLER/ENCODER

SS2000

SS2000R

SS2000T

SS2000TR

INSTALLATION AND OPERATION INSTRUCTIONS



FEDERAL SIGNAL CORPORATION

2645 Federal Signal Drive, University Park, IL 60466

Phone: (708) 534-3400 FAX: (708) 534-4855

SS2000
255286
REV H2 10/07/03

SAFETY NOTICES

People's lives depend on your selection of suitable equipment and installation sites and your safe installation, service, and operation of our products. Federal Signal recommends the following publications from the Federal Emergency Management Agency for assistance with planning an outdoor warning system: 1. The "Outdoor Warning Guide (CPG 1-17), 2. "Civil Preparedness, Principles of Warning" (CPG 1-14), 3. FEMA-REP-1, Appendix 3 (Nuclear Plant Guideline), and 4. FEMA-REP-10 (Nuclear Plant Guideline). Contact Federal Warning System's Customer Care Center at: <http://www.federalwarningsystems.com> or 1-800-524-3021 for further information about these publications.

It is important to read, understand and follow all instructions shipped with this product. In addition, listed below are some other important safety instructions and precautions you should follow.

PLANNING

- If suitable warning equipment is not selected, the installation site for the siren is not selected properly or the siren is not installed properly, it may not produce the intended optimum audible warning. Follow Federal Emergency Management Agency (FEMA) recommendations.
- If sirens are not activated in a timely manner when an emergency condition exists, they cannot provide the intended audible warning. It is imperative that knowledgeable people, who are provided with the necessary information, are available at all times to authorize the activation of the sirens.
- When sirens are used out of doors, people indoors may not be able to hear the warning signals. Separate warning devices or procedures may be needed to effectively warn people indoors.
- The sound output of sirens is capable of causing permanent hearing damage. To prevent excessive exposure, carefully plan siren placement, post warnings, and restrict access to areas near sirens.
- Activating the sirens may not result in people taking the desired actions if those to be warned are not properly trained about the meaning of siren sounds. Siren users should follow FEMA recommendations and instruct those to be warned of correct actions to be taken.
- A siren that doesn't work won't provide any warning. After installation, service, or maintenance, test the siren system to confirm that it is operating properly. Test the system regularly to confirm that it will be operational in an emergency.
- If future service and operating personnel do not have these instructions to refer to, the siren system may not provide the intended audible warning and service personnel may be exposed to death, permanent hearing loss, or other bodily injury. File these instructions in a safe place and refer to them periodically. Give a copy of these instructions to new recruits and trainees. Also give a copy to anyone who is going to service or repair the siren.

SAFETY NOTICES

People's lives depend on your safe installation, service and operation of our products. It is important to read, understand and follow all instructions shipped with this product. In addition, listed below are some other important safety instructions and precautions you should follow:

INSTALLATION & SERVICE

- Electrocution or severe personal injury can occur when performing various installation and service functions such as making electrical connections, drilling holes, or lifting equipment. Therefore experienced electricians in accordance with national, state and any other electrical codes having jurisdiction should perform installation. All work should be performed under the direction of the installation or service crew safety foreman.
- The sound output of sirens is capable of causing permanent hearing damage. To prevent excessive exposure, carefully plan siren placement, post warnings and restrict access to areas near the sirens. Sirens may be operated from remote control points. Whenever possible, disconnect all siren power including batteries before working near the siren.
- After installation or service, test the siren system to confirm that it is operating properly. Test the system regularly to confirm that it will be operational in an emergency.
- If future service personnel do not have these warnings and all other instructions shipped with the equipment to refer to, the siren system may not provide the intended audible warning and service personnel may be exposed to death, permanent hearing loss, or other bodily injury. File these instructions in a safe place and refer to them periodically. Give a copy of these instructions to new recruits and trainees. Also, give a copy to anyone who is going to service or repair the sirens. For additional copies, call the Federal Warning Systems Customer Care Center at 800-524-3021 or write to them at 2645 Federal Signal Drive, University Park, IL 60466.

OPERATION

- Failure to understand the capabilities and limitations of your siren system could result in permanent hearing loss, other serious injuries or death to persons too close to the sirens when you activate them or to those you need to warn. Carefully read and thoroughly understand all safety notices in this manual and all operations-related-items in all instruction manuals shipped with equipment. Thoroughly discuss all contingency plans with those responsible for warning people in your community, company, or jurisdiction.

Limited Warranty

*The Signal Division, **Federal Signal Corporation**, warrants each new product to be free from defects in material and workmanship, under normal use and service, for a period of two years (one year for Informer, EAS, and Federal software products) on parts replacement and one year on labor from the date of delivery to the first user-purchaser. Federal Warning Systems warrants every 2001 Siren (Top of pole only) to be free from defects in material, per our standard warranty, under normal use and service for a period of Five years on parts replacement.*

During this warranty period, the obligation of Federal is limited to repairing or replacing, as Federal may elect, any part or parts of such product which after examination by Federal discloses to be defective in material and/or workmanship.

Federal will provide warranty for any unit which is delivered, transported prepaid, to the Federal factory or designated authorized warranty service center for examination and such examination reveals a defect in material and/or workmanship.

This warranty does not cover travel expenses, the cost of specialized equipment for gaining access to the product, or labor changes for removal and re-installation of the product. The Federal Signal Corporation warranty shall not apply to components or accessories that have a separate warranty by the original manufacturer, such as, but not limited to, batteries.

This warranty does not extend to any unit which has been subjected to abuse, misuse, improper installation or which has been inadequately maintained, nor to units which have problems related to service or modification at any facility other than Federal factory or authorized warranty service centers.

THERE ARE NO OTHER WARRANTIES, EXPRESSED OR IMPLIED, INCLUDING BUT NOT LIMITED TO, ANY IMPLIED WARRANTIES OF MERCHANTABILITY OR FITNESS FOR A PARTICULAR PURPOSE. IN NO EVENT SHALL FEDERAL BE LIABLE FOR ANY LOSS OF PROFITS OR ANY INDIRECT OR CONSEQUENTIAL DAMAGES ARISING OUT OF ANY SUCH DEFECT IN MATERIAL WORKMANSHIP.



FEDERAL SIGNAL
Federal Warning Systems

2645 Federal Signal Drive, University Park, IL 60466
Phone: (800) 524-3021 Fax: (708) 534-4865
Website: <http://www.federalwarningsystems.com>

TABLE OF CONTENTS

<u>SECTION</u>	<u>TITLE</u>	<u>PAGE NO.</u>
Section I	CHARACTERISTICS	1
1.1	General	1
1.2	SpecificationsSS2000	2
SS-REMOTE	3
1.3	SS2000 Operation	4
Section II	INSTANT MODES	6
2.1	Automatic Mode	6
2.2	Manual Mode	7
2.3	Report Mode	9
2.4	Printer Mode	10
Section III	EXTENDED MODES	11
3.1	Program Mode	11
3.2	Config Mode	12
3.3	Calibration Mode	15
3.4	Monitor Mode	16
3.5	Download Mode	17
3.6	Upload Mode	18
3.7	Configuration Parameters File (DAT file)	20
Section IV	INSTALLATION	23
4.1	General	23
4.2	Connections and adjustments	23
4.3	SS-REMOTE Installation	25
Section V	TESTING	27
5.1	Self Test Feature	27
5.2	Test 1 - LCD	28
5.3	Test 2 - LED	28
5.4	Test 3 - KEYS	28
5.5	Test 4 - RELAY	29
5.6	Test 5 - DTMF	30
5.7	Test 6 - FSK	31
Section VI	PERIPHERALS	32
6.1	SS-REMOTE	32
Section VII	WIRING DIAGRAM	34
Section VIII	ADDENDUMS	35

SECTION I CHARACTERISTICS

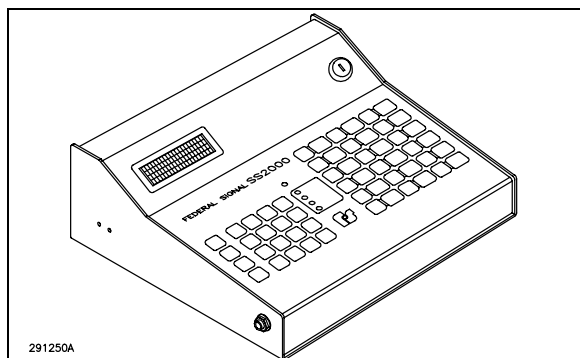

Fig. 1.1: SS2000 Desk Model

1-1. GENERAL

The SS2000 is a versatile, low cost siren controller. The controller is available with one-way control and two-way status monitoring options. The DTMF encoded command sequences are programmable and stored in non-volatile memory for retention even when electrical power is removed. Command sequences and operating parameters may be up or downloaded to the user's host computer. Power for the unit is supplied by a standard AC wall outlet and backed-up with an optional battery.

The SS2000 functions as a stand-alone DTMF encoder for one-way siren control. With an optional printer, reports can be generated for each activation showing the function activated and the time and date of activation.

When the two-way controller option is purchased, reports are also generated for all two-way controlled remote siren sites. Reports indicate siren site number, type of siren, detailed status of siren, and time and date of the report.

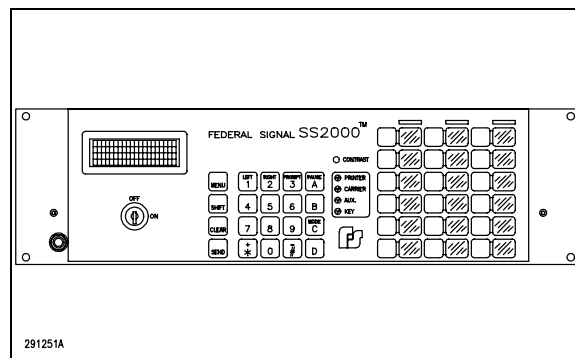

Fig. 1.2: SS2000 19" Rack Mount

Special two-way control features are indicated by an asterisk () next to the feature, through out the manual. Some two-way features may not be accessible on one-way units.*

All SS2000 controllers feature a four line backlit wide angle LCD display, a full DTMF keypad, and 18 user programmable function keys. Four LEDs are used to indicate printer, RF carrier detect, key press and computer communication status. A key lock is provided to secure the controller's keypad. There is also an adjustable 600 ohm input and output to enable easy connection to standard radio and land line mediums.

A speaker is built in for monitoring incoming system traffic and outgoing transmissions.

A microphone input is provided to connect live voice to the communication system.

Advanced features:

- Multiple SS2000s can be setup to form a control network of base stations. Each SS2000 in this configuration will keep all peer base stations acknowledged of the activations at its site by transmitting an update string following each

activation. All receiving base stations in the network will print a hard copy report indicating the active base station number and the function activated by it along with the time and date of activation.

*STATUS MAP:

The SS2000 is capable of communicating to a status map through its serial port, turning ON multicolor LEDs on the status map representing conditions at the remote siren sites.

Options:

SS-REMOTE:

The SS-REMOTE is an interface unit to the SS2000 which enables activation from remote contact closures. Up to 20 functions may be activated from distances exceeding 1 mile.

1-2. SPECIFICATIONS

THE SS2000:

Electrical

Power Supply Input.....	11.5 - 20 VDC
Battery Input.....	11.5 - 20 VDC
Input Current	400 mADC (MAX)
Audio Output.....	Balanced 600 ohm, -55dbm to 0dbm
*Audio Input.....	Balanced 600 ohm, -35dbm to 0dbm
Distortion	< 3.0%
Encode / Decode Format	
DTMF.....	35/5 to 1000/1000 in milli-seconds (digit duration/inter digit silence)
*Decode Sensitivity.....	20db S/N
Relay Outputs.....	3 DPDT 1.25A at 24 VDC 0.4A at 120 VAC
Carrier Detect.....	Active High 4.5 - 14 VDC Active Low 0 - 3.0 VDC

VOX..... -35dbm to 0dbm

SPEAKER: Power Handling..... 1 watt
Impedance..... 8 ohms

MICROPHONE: Input Level..... 10mV - 100mV p-p
Input Impedance..... 12K ohms
Input Jack..... 1/4" phone
Pinouts: Tip.....Audio
Ring.....PTT
Shield....Gnd

Communication Ports

Parallel Port..... IBM Compatible Printer Port
Serial Port Protocol..... RS232 9600 BAUD, N, 8, 1, Xmodem Standard

Environmental

Operating Temperature..... 0° to 50°C

Physical

Size..... Desk model, 11.57 x 10.25 x 4.20 L x W x H inches
Rack model, 19.0 x 10.09 x 5.24 L x W x H inches

THE SS-REMOTE:

Electrical:

Input Voltage 14.5 Volts
Input Current 15 mAmps (Typical)
Maximum Input Contact Resistance 500 ohms
Max. tolerable induced voltage 500 Volts
Input/Output Isolation (opto coupler) 5000 Vac

Maximum length of Remote
Connector Cable (10 ohm/ 1000 ft) 30,000 ft.
Maximum wire gauge 12 AWG
Maximum length of I²C connector 3 ft.

Maximum number of remote contacts 20
Remote input debounce 1/4 sec

Physical:

Size	11.4 x 4.0 x 2.08 inches
Weight	1.0 lb.
Color	Black
Operating Temperature	0° to 50°C

Communication Modes:

1-3. SS2000 OPERATION

The SS2000 keypad is secured with a key lock switch. When the key is in the OFF position, the LCD displays the "*** Keypad Locked ***" message along with the following information: (See figure 1.1)

- The type of the controller: Either SS2000 or SS2000T depending on whether the controller has one-way or two-way control options respectively.
- Current software revision.
- Current operating mode. (in the lower right corner of the LCD).



Fig. 1.1: Keypad Locked

When the key is turned to ON position, the keypad becomes enabled and MAIN MENU displays on the LCD. The unit is now ready to accept the commands. (See figure 1.2)

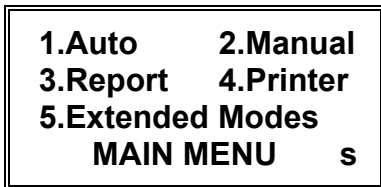

Fig. 1.2: Main Menu

The SS2000 has an extensive yet simple to operate command structure. There are three communication modes for the SS2000. These modes are depicted in the lower right corner of the SS2000 LCD by a single character. (On the MAIN MENU, EXTENDED MENU and 'Keypad Locked' displays). The User should select these modes carefully as they affect the way the SS2000 will operate. Selecting the wrong communication mode may cause undesirable operation of the unit. The mode's setting is stored in FLASH memory. Powering down the unit does not alter the user selected settings. These modes are defined as follows:

STANDARD MODE (s):

This is the basic operating mode and is represented by 's' in the lower right corner of the LCD. **Configuration values (DAT file) can be downloaded or uploaded in this mode ONLY.** (See section 3.5 and 3.6 for downloading and uploading of DAT file). The SS2000 can not communicate with either the map or the MMI-1000 computer in this mode.

*MAP MODE (m):

This mode is represented by 'm' in the lower right corner of the LCD. In this mode the SS2000 can communicate with the map hooked up to its serial port but can not communicate with the MMI-1000 computer.

*COMPUTER MODE (c):

This mode is represented by 'c' in the lower

right corner of the LCD. In this mode the SS2000 can communicate with the MMI-000 computer. **All of the SS2000 activities can be accessed and controlled by the MMI-1000 computer** (with the exception of UPLOAD and DOWNLOAD modes). This mode is not recommended for direct map interface to the SS2000. In case of a communication problem with the computer the SS2000 turns on the AUX LED.

To switch between modes press ‘SHIFT’ and then press ‘c’ from the MAIN MENU.

Note: In this manual the SS2000 is shown to be in the Standard (s) mode. The map(m) mode and the computer(c) mode are not different from the users point of view, except for UPLOAD, DOWNLOAD modes and the differences discussed above. Hence, this manual also applies to map(m) and computer(c) modes of operation.

Commands or functions are divided into two broad categories:

- Instant Mode functions (MAIN MENU): These include the commands which are commonly executed on a frequent basis like activation, remote site monitoring and printer status checking. There are four instant mode functions in the MAIN MENU. (See figure 1.2)
- Extended Mode functions (EXTENDED MENU): These functions deals with programming, configuring, calibrating, monitoring, downloading, uploading and setting up the SS2000 unit. These are as shown in fig. 1.3.

EXTENDED MENU s

Fig. 1.3: Extended Menu

To choose a function from the MAIN MENU or the EXTENDED MENU, press the number corresponding to the function.

Press MENU key to switch to MAIN MENU or SHIFT+MENU key to switch to EXTENDED MENU from anywhere in the system.

Beside selecting the Instant Mode functions following operations are directly possible from the MAIN MENU:

SHIFT+C: Changes the communication mode. (Available in all modes.)

*SHIFT+CLEAR: Clears the map LEDs. (Available in computer(c) and map(m) modes)

CLEAR: Clears the AUX LED. (Available in computer(c) mode.)

1.Program	2.Config
3.Calib	4.Monitor
5.Download	6.Upload

SECTION II INSTANT MODES

2-1. AUTOMATIC MODE

Automatic mode provides the user a quick and easy method of sending activation commands. Only two key presses are required to activate a single function. (In some special cases only one key press could cause the activation. See SS-REMOTE).

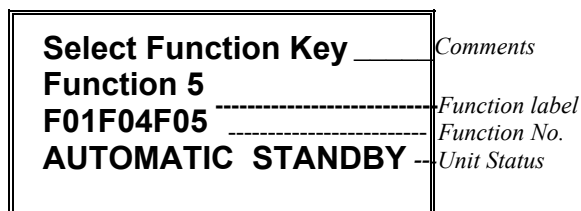

Fig. 2.1: Automatic Mode

To access AUTOMATIC MODE:

There are three ways to access Auto Mode:

1. Press number 1 from the MAIN MENU.
2. Press one of the eighteen preprogrammed function keys from anywhere in the system. This will cause the SS2000 to enter the AUTOMATIC mode and show the selected function on the LCD. (Automatic mode cannot be accessed directly from CONFIG, PROGRAM or DOWNLOAD modes.)
3. Activate an input on the SS-REMOTE.

Automatic mode is indicated by the word AUTOMATIC in the lower left corner of the LCD. The current status is displayed in the lower right corner. (Refer to fig. 2.1).

To add function(s):

- While in the AUTOMATIC mode pressing any of the eighteen function keys adds that function key to the list of the functions to be transmitted. A

maximum of sixteen functions can be stacked at a time.

- As each function key is pressed, the key label is displayed for that key and the function key number is added to the list of functions to be transmitted.
- Pressing CLEAR erases the entire function list.

To transmit function(s):

- Press SEND when done stacking up the functions.
- The unit status changes to TRANSMIT as the SS2000 starts transmitting each function in the list.
- The function label displays as each function is transmitted.
- A transmission report is sent to the printer for each function transmitted. An activation log is also sent to the MMI-1000 if the SS2000 is in the computer(c) mode. (In the network environment, function activation information is also transmitted to the peer base stations.)

NOTE: Any function key press following the SEND (after the transmission is completed or aborted) erases the transmitted / aborted function list and starts a new function list.

To abort transmission:

- Press CLEAR key to abort transmission (if it is ever needed) while in TRANSMIT state. The unit status returns to STANDBY without clearing the function list.

To exit AUTOMATIC mode:

The AUTOMATIC mode can be exited while the unit status is in STANDBY.

- Press the MENU key to exit to MAIN MENU.
- Press SHIFT+MENU keys to exit to EXTENDED MENU.

KEYs and their related functions specific to Automatic Mode are as follows:

MENU

Exits to Main Menu

SHIFT+MENU

Exits to Extended Menu

CLEAR

Clears the function key list if in STANDBY. Aborts the transmission if in TRANSMIT.

SEND

Transmits the DTMF strings associated with each function key in the list.

2-2. MANUAL MODE

Manual mode is used when the user wishes to transmit specific DTMF codes. The user must have a detailed understanding of the format and effect of transmitted DTMF codes before using MANUAL MODE.

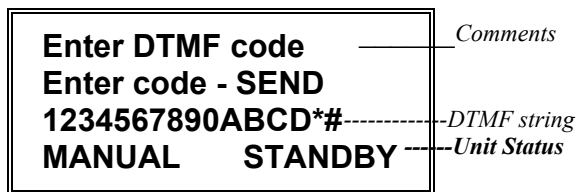

Fig. 2.2: Manual Mode

To access MANUAL MODE:

- Press '2' from MAIN MENU.

Manual Mode display appears with unit status as STANDBY as shown in fig. 2.2.

To enter DTMF string:

- Key in the required DTMF string using **DTMF keys** (1234567890ABCD*#), pauses, prompt and auto reports. Each key press will be reflected in line 3 of the LCD.
- Up to 64 DTMF digits may be entered.
- Use CLEAR key to erase the entire string and start over.

To transmit the DTMF string:

- Press SEND key to transmit the entered DTMF string.
- Unit status changes to TRANSMIT and the DTMF string gets transmitted.
- Upon completion of transmission the unit status returns to STANDBY and a transmission message is sent to the printer. An activation log is also sent to the MMI-1000 if the SS2000 is in the computer mode. (In the network environment, manual activation information is also transmitted to the peer SS2000s.)

To abort the transmission:

- Press CLEAR key to abort the transmission, if it becomes necessary, while in the TRANSMIT state. The unit status changes to STANDBY.

To exit MANUAL MODE:

- Press MENU to exit to MAIN MENU.
- Press SHIFT+MENU to exit to EXTENDED MENU.

Special entries:

- **Pauses** can be inserted within the DTMF string by pressing the SHIFT+PAUSE keys.
 - When a Pause is entered, it will be displayed on the LCD screen as an "=" .
 - During transmission, the controller will wait one Pause time (as defined in

CONFIG mode) for each Pause (=) entered.

- This feature is useful for sending two separate commands spaced in time with only one keypad entry.
- The SS2000 normally keeps the PTT high for the duration of pause time. It will, however, drop the PTT if the total pause time, at a given instance, is more than 10 seconds.
- **Prompts** (SHIFT+PROMPT) can be inserted to transmit repetitive strings.
 - By inserting a prompt within the DTMF string the user can change a section of the code without retyping the entire code.
 - There are three types of prompts represented by numbers: 1= Site, 2 = Zone, 3 = Function.
 - When a prompt is entered it will be displayed on the LCD screen as a "?". The user will then be prompted "Enter prompt type". Either 1, 2, or 3 (Site, Zone, Function) must then be entered. This entry will be displayed but will not be transmitted as a digit. When SEND key is pressed, the user will be prompted to enter the Site, Zone, or Function digits (1 to 3 digits).
 - These digits will replace the "?" and will be transmitted as part of the DTMF string.
 - Each time SEND key is pressed, new digits can be added at the prompt.
 - However, it is more convenient to program such features under function keys, so that they can be accessed by just one key press in Automatic Mode. (Refer to PROGRAM mode section 3-2 for programming function keys).
- ***Auto Report'+'** (SHIFT + plus key) can be added to the end of the DTMF string to poll the sirens automatically to check their status.
 - Auto Report feature is useful to verify

the remote siren status after an activation or a quiet test.

- Auto Report has a built in delay of 20 seconds before it starts polling the sirens.

KEYs and their related functions specific to MANUAL mode are as follows:

DTMF digit

Adds DTMF digit to the temporary buffer.

MENU

Exits to Main Menu.

SHIFT+MENU

Exits to Extended Menu.

CLEAR

In STANDBY clears the contents of the temporary buffer. In TRANSMIT aborts the transmission.

SHIFT+PAUSE

Adds a pause character to the temporary buffer.

SHIFT+PROMPT

Adds a prompt character to the temporary buffer. The user will be asked for the prompt type (1, 2, or 3).

***PLUS character (SHIFT+*)**

Adds a call to Auto Report function.

If added, this must be last character in the string to be transmitted.

SEND

Transmits the currently displayed DTMF string. (contents of the temporary buffer.)

2-3. *REPORT MODE

Report mode (used in two-way systems only) is used to poll sites and obtain their current status. The list of sites to be polled is defined in the configuration parameters (see CONFIG mode). A report request message (also defined in CONFIG mode) is sent to each site in the site list. If a response is not received within the specified report time-out period (also defined in CONFIG mode), the request is re-transmitted. This process is repeated for the number of report retries (specified in the CONFIG mode). If a site's response is received, it is formatted and sent to the printer.

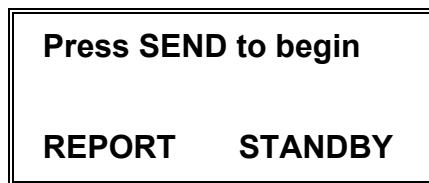

Fig. 2.3: Report Mode

To access Report Mode:

- Press '3' from the MAIN MENU.
Report Mode display appears on the LCD with STANDBY as unit status, as shown in fig 2.3.

To request reports:

- Press SEND key to start polling the remote siren sites.
- Unit status changes to TRANSMIT and the SS2000 starts transmitting the report requests to the sites defined in the CONFIG mode one at a time.
- The polled site number displays in the second line on the LCD.
- Polling can be aborted by pressing CLEAR key.
- If the polled site responds with a valid status information message, it is formatted

and printed on the attached printer.

- The received report information is also sent to the status map attached if the SS2000 is in map (m) mode, or to the MMI-1000 if the SS2000 is in the computer(c) mode.
- If a report is not received from the polled site during the report timeout period (defined in CONFIG mode) the request is repeated for the number of times as specified by the Report Retries (defined in CONFIG mode.) A 'Site did not respond' message is then sent to the printer and/or to the MMI-1000 depending on the SS2000 operating mode.

To exit REPORT MODE:

- Press MENU to exit to MAIN MENU.
- Press SHIFT+MENU to exit to EXTENDED MENU.

KEYS and their related functions specific to Report Mode are as follows:

MENU

Exits to Main Menu.

SHIFT+MENU

Exits to Extended Menu.

SEND

Begins report polling sequence.

CLEAR

Aborts report polling sequence.

AUTO REPORT: ('+' character)

- A plus (+ is SHIFT+*) can be added:
 - to the end of a manual DTMF string.
 - to the end of an Alarm string.
 - to the end of the function string.
- System translates '+' sign as if SEND key is pressed in the REPORT mode and starts polling all predefined sites. This feature is

useful to:

- check the remote site status on regular intervals (Alarm mode)
- verify the remote site status after manual or automatic activation.
- When triggered Auto Report waits for 20 seconds before it starts polling the sites.
- In Wait state Auto Report does not accept any key presses except CLEAR. Pressing CLEAR aborts the Auto Report.
- Auto Report display looks like this:



Fig. 2.3.b: Auto Report

2-4. PRINTER MODE

The purpose of the PRINTER mode is to monitor the printer status. In this mode one of the LCD displays messages regarding printer's status. The Printer LED, goes on every time the SS2000 sends something to the printer. The LED can also be turned off in this mode by pressing CLEAR key.

To access PRINTER mode:

- Press number '4' from the MAIN MENU.
- PRINTER MODE messages with the unit status STANDBY appears on the LCD.
- First line of the LCD displays the Printer Status Messages, which are as follows:

NO Paper

Printer is out of paper or the paper is jammed.

Printer Off-line

Printer's Select or On-line switch is toggled off.

Printer Error

Printer malfunction.

Printer OK

Printer is ready.

LED ON - Press CLEAR

This message is displayed on the second line of the LCD. The SS2000 turns the printer LED on whenever it sends data to the printer. The printer LED can be turned off here by pressing CLEAR key.

To exit the PRINTER MODE:

- Press MENU to exit to MAIN MENU.
- Press SHIFT+MENU to exit to EXTENDED MENU.

KEYs and their related functions specific to Printer Mode are as follows:

MENU

Exits to Main Menu.

SHIFT+MENU

Exits to Extended Menu.

CLEAR

Clears the printer alert LED.



Fig. 2.4: Printer Mode

SECTION III EXTENDED MODES

The following extended functions can be accessed by selecting (5) Extended Modes from the MAIN MENU.

3-1. PROGRAM MODE

The Program mode allows for unique and custom programming of the function keys to meet the specific needs of the user. The 18 Function keys are completely versatile giving the user the power to create a variety of convenient execution parameters.

The Program mode is used to store DTMF sequences in a given Function key. These 18 function keys are later used in AUTOMATIC mode.

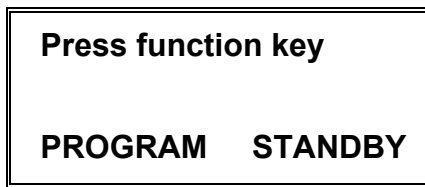

Fig. 3.1a: Program Mode

To access PROGRAM MODE:

- Press '1' from the EXTENDED MENU. PROGRAM mode appears on the LCD with unit status as STANDBY as shown in fig. 3.1a.

To program a function key:

- Press desired function key button to enter into the edit session. LCD changes as shown in fig. 3.1b.

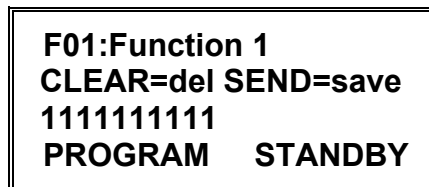

Fig. 3.1.b: Program Mode

- Line 1 displays function number and function label.

Note: Function labels can only be changed in the DAT file. Refer to section 3.5 for downloading of DAT file information.

- Line 3 displays the present contents of the selected function key.
- Line 2 provides user with two options:
 - Erase the present contents to enter a new DTMF string by pressing CLEAR key.
 - Secure the present contents as they are and quit the edit session by pressing SEND key.
- If the user presses CLEAR key then line 3 goes blank allowing the user to enter new DTMF string.
- The user may key in up to 64 DTMF digits including pauses, prompts, auto report, auto SEND and auto CLEAR key. (Use of prompt, pause and auto report function is explained in section 2.2 and 2.3.)
- If a mistake is made press CLEAR to erase the entire string and re-enter.
- When done with entering the DTMF string press SEND to save the entry and to quit edit session.
- Display goes back to Fig. 3.1a. To program another function press the desired function key.

To exit PROGRAM MODE:

- Press MENU to exit to MAIN MENU.
- Press SHIFT+MENU to exit to EXTENDED MENU.

KEYs and their related functions specific to Program Mode are as follows:

MENU

Exits to Main Menu.

SHIFT+MENU

Exits to Extended Menu.

FUNCTION KEY(F01...F18)

Display the contents of the function key.

SHIFT, LEFT ARROW

Scrolls the DTMF string to the left if the string does not fit on the display line.

SHIFT, RIGHT ARROW

Scrolls the DTMF string to the right if the string does not fit on the display line.

CLEAR

Clears the contents of the currently displayed Function key and enters edit session. In edit session erases the entire string entered for re-entry.

DTMF digit

Displays the entered digit and adds it to the buffer in edit session.

SHIFT+PAUSE

Adds a pause character to the temporary buffer.

SHIFT+PROMPT

In edit session , adds a prompt character to the current DTMF string. The user will be asked for the prompt type (1, 2, or 3).

***PLUS character (SHIFT+*)**

Adds an auto report request to the function. This must be either the only or the last in the function string. (Auto SEND can supersede Auto Report).

Auto CLEAR (SHIFT+CLEAR)

- A CLEAR key can be programmed within a function by pressing SHIFT+CLEAR in the Program Mode.
- Auto CLEAR appears as 'k' on the LCD.
- If programmed, it should be the first character in the string.
- In Automatic Mode, upon encountering an Auto CLEAR embedded in a function the SS2000 does the following:
 - Erases the entire function list prior to the said function.
 - Starts a new function list with the said function as the first member.

Auto SEND (SHIFT+SEND)

- A SEND key can be programmed within a function by pressing SHIFT+SEND in the Program Mode.
- Auto SEND appears as 'S' on the LCD.
- If programmed, it should be the last character in the string.
- In Automatic Mode, upon encountering an Auto SEND embedded in a function the SS2000 automatically starts transmitting the function list without waiting for the send key to be pressed.

SEND

Accepts the currently displayed DTMF string and stores it in the target function key.

3-2. CONFIG MODE

The SS2000 contains a data file which configures the SS2000 for proper operation. The Config Mode is used to view and edit the data in this file. *The entries in this mode are extremely critical for the total system operation. Therefore, the user accessing this mode must be very familiar with the overall system requirements and configurations.*

When CONFIG mode is accessed, the user is prompted to enter a password. The password should be keyed in followed by

the SEND key. Once a valid password is entered, the user may review or modify the parameters.

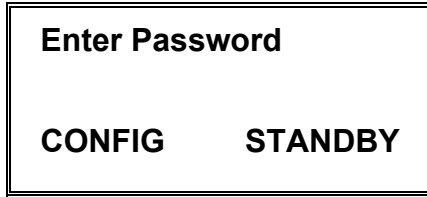

Fig. 3.2a: Config Mode-password

To access CONFIG MODE:

- Press '2' from the EXTENDED MENU. CONFIG mode appears on the LCD with unit status as STANDBY as shown in fig. 3.2a.
- Enter password followed by the SEND key to review or modify the configuration parameters. Upon entering the valid password, the first configuration parameter is displayed on the LCD, as shown in fig. 3.2b.

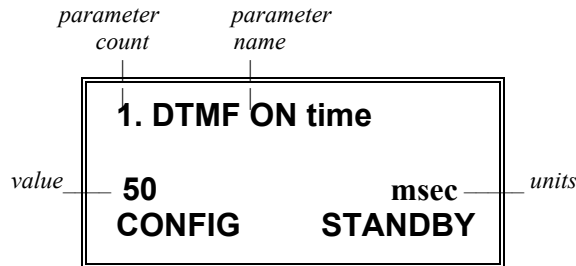

Fig. 3.2.b: Config Mode-review

To review configuration parameters:

- Each SEND key press brings up the next configuration parameter for review.

To modify configuration parameters:

- With the required parameter on the display press CLEAR key to enter 'modify' session. The LCD changes as shown in fig. 3.2c.

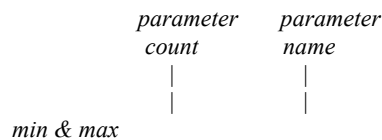

values-----
new entry-----

Fig. 3.2c: Config Mode-modify

- Line 1 displays parameter count # and parameter name.
- Line 2 displays minimum and maximum acceptable values for that particular parameter. (or it will be 0...1 for yes/no type of replies.)
- The third line is for user to enter a new value.
- If a mistake is made, press CLEAR to erase the entry and re-enter.
- When done with entering the new value, press SEND **twice** to secure and confirm the new entry. This terminates the 'modify' session and puts the user back into 'review' session.

To exit CONFIG MODE:

- Press MENU to exit to the MAIN MENU.
- Press SHIFT+MENU to exit to the EXTENDED MENU.

KEYs and their related actions are as follows:

MENU

Exits to the Main Menu.

SHIFT+MENU

Exits to the Extended Menu.

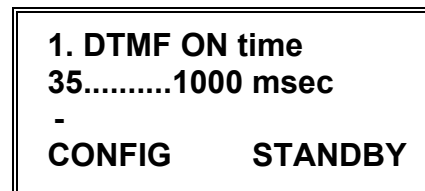

CLEAR

Clears the current parameter and begins modify session.

DIGIT KEYS

Used to enter information.

SEND

During 'review' session, proceeds to the next configuration parameter.

During 'modify' session, validates the newly entered value for the current parameter. If a valid entry has been made, the new value is redisplayed. *To save a valid entry and to move on to the next step, SEND has to be pressed twice.*

CONFIGURATION PARAMETERS

Count, name (label), limits and definitions:

1. DTMF on time: *35 to 1000 msec*

On time for DTMF characters.

2. DTMF off time: *5 to 1000 msec*

Off time for DTMF characters.

3. Front porch time: *5 to 9999 msec*

Front porch time for DTMF message.

4. Back porch time: *5 to 9999 msec*

Back porch time for DTMF message.

5. Pause duration: *5 to 9999 msec*

The amount of time system will pause when it sees a pause (=) character during DTMF transmission. Multiple pauses can be cascaded.

6. *Report timeout: *1 to 9999 sec*

The time that SS2000 will wait for remote siren site to respond to a report request before resending or quitting the report request to that particular remote site.

7. *Report Attempts: *1 to 9*

Number of times the request for report will be sent to a non responding remote site.

8. Carrier Detect active state: *0 or 1*

0 = active low, 1 = active high

9. Use Printer: *0 or 1*

0 = no printer, 1 = printer

10. Encrypt messages: *0 or 1*

0 = no encryption, 1 = encryption

(Consult Federal Signal Applications Engineering before selecting encryption.)

11. Password: *up to 5 DTMF digits*

Password to access CONFIG mode.

12. Date:

Month *1 to 12*

Day *1 to 31*

Year *1993 to 2100*

13. Time:

Hour *1 to 23*

Minutes *1 to 59*

Seconds *1 to 59*

14. Alarm Time:

Hour *1 to 23*

Minutes *1 to 59*

Time to automatically transmit alarm string.

15. Alarm String:

This string will be automatically transmitted at alarm time on daily, weekly or monthly basis depending on Alarm Interval setting (parameter# 18). Up to 64 DTMF characters are possible which could include prompts, pauses and auto report (+) characters. (If auto report (+) is used, it must be last character in the string.)

16. *Report String:

Up to 64 DTMF digits (including a site number prompt) to request report from remote siren sites.

17. *Site Addresses:

Up to 100 remote sites may be programmed (each beginning with '#').

18. Alarm Interval: 0, 1 or 2

Specifies the frequency of alarm activation.

0=Daily alarm activation.

1=Weekly alarm activation.

2=Monthly alarm activation.

19. Alarm Day: 0 to 7

This option will only be displayed if the Alarm Interval is either 1 or 2. This is to specify the day of the week or the day of the month for alarm activation.

1=Sun, 2=Mon, 3=Tue, 4=Wed, 5=Thurs, 6=Fri, 7=Sat.

Examples:

- If Alarm Interval=1 and Alarm Day=3. The Alarm Sequence will be activated every week on Tuesday.
- If Alarm Interval=2 and Alarm Day=3. The Alarm Sequence will be activated on first Tuesday of every month.
- **If Alarm Interval=2 and Alarm Day=0. Alarm will never be activated. Use this setting to disable the alarm feature.**

20. *Unit ID: 0 to 99

This is the SS2000's unit ID. Default for this parameter is 0. If the SS2000 is not used in networking mode then this parameter **must** always remain 0.

21. Operating Mode: 0, 1 or 2

0=Standard mode.

1=Map mode.

2=computer (MMI-1000) mode.

For user's convenience, this setting can also be changed from Main Menu by pressing SHIFT+C.

22. Computer LCD: 0 or 1

This option will only be displayed if Operating Mode (parameter #21) is 2.

0=LCD messages to the MMI-1000 disabled.

1=LCD messages to the MMI-1000 enabled.

3-3. CALIBRATION MODE

The SS2000 typically operates with radios attached. The output level of DTMF strings going into the attached radio is adjusted using Calibration mode. Calibration mode allows the user to transmit a single DTMF digit for 10 uninterrupted seconds. Refer to section 4-2 for adjustment information.

Note: Radios typically transmit different DTMF digits at slightly different levels. Set output for an average of 3 - 3.3KHz deviation.



Fig. 3.3: Calibration Mode

To access CALIBRATION (CAL) MODE:

- Press '3' from the EXTENDED MENU. CAL mode appears on the LCD with unit status as STANDBY as shown in fig. 3.3.

To transmit calibration character:

- Press any DTMF character. The selected character appears in the third line of the LCD.
- Press SEND to begin transmission.
- The SS2000 transmits the character for continuous 10 seconds and then shuts it off.
- To transmit the same character again simply press SEND.

To exit CAL MODE:

- Press MENU to exit to MAIN MENU.
- Press SHIFT+MENU to exit to EXTENDED MENU.

KEYs and their related actions specific to CAL Mode are as follows:

MENU

Exits to Main Menu.

SHIFT+MENU

Exits to Extended Menu.

CLEAR

Clears the currently displayed DTMF character.

DTMF digit

Displays the DTMF digit entered. Only one DTMF digit is allowed. If another digit is pressed, it replaces the previous digit.

SEND

Transmits the DTMF digit (if any) for 10 seconds.

3-4. MONITOR MODE

The SS2000 can be set in Monitor mode in order to display received DTMF digits on the LCD. Received DTMF digits are stored in a buffer. Last 20 of the received DTMF

digits are displayed in third line of the LCD. A new digit received is placed at the end of the buffer and the display is rotated to the left by one. Pressing the CLEAR key erases the entire contents of the buffer. Each message string received is terminated with a "Z" for clarity.

Fig. 3.4: Monitor Mode

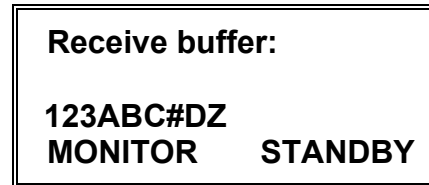

To access MONITOR MODE:

- Press '4' from the EXTENDED MENU. MONITOR mode appears on the LCD with unit status as STANDBY as shown in fig. 3.4.

To clear the receive buffer:

- Press CLEAR key to clear the receive buffer as well as the LCD.

To exit MONITOR MODE:

- Press MENU to exit to MAIN MENU.
- Press SHIFT+MENU to exit to EXTENDED MENU.

KEYs and their related actions specific to Monitor mode are as follows:

MENU

Exits to the Main Menu.

SHIFT+MENU

Exits to the Extended Menu.

CLEAR

Clears the receive buffer.

3-5. DOWNLOAD MODE

The SS2000 configuration parameters may be stored in a remote computer and transferred into the SS2000 as needed. This allows centralized maintenance and storage of parameters with the flexibility to modify and download as needed. Downloading is performed using the XMODEM communications protocol. Configuration parameters are normally stored in a file with DAT extension.

The Download mode is ONLY accessible when the SS2000 is operating in the Standard (s) mode. In other operating modes an attempt to access Download mode displays 'Download Mode Not accessible' message.

-Caution-
Downloading bad or incomplete data will make the SS2000 inoperable. Do not attempt to execute this function until section 3-8 and a serial communication program such as SSWIN© or Microsoft HyperTerminal© is thoroughly understood.

Before accessing Download Mode make sure that the SS2000 is connected to the serial port of an IBM compatible computer through RS232 serial cable, and that a serial communication program such as SSWIN© or Microsoft HyperTerminal© is active on the computer. The proper communication settings are N, 8, 1 at 9600 baud.

At this point a mirror image of the SS2000 LCD must appear in the upper left corner of the computer LCD. If the SS2000 LCD is not reflected on the computer screen then either the physical connection or the COM

port settings are in error.



**Press SHIFT SEND to
DOWNLOAD
or MENU to EXIT
DOWNLOAD STANDBY**

Fig. 3.5a: Download Mode

To access DOWNLOAD mode:

- Press '5' from the EXTENDED MENU. DOWNLOAD mode appears on the LCD with unit status as STANDBY as shown in fig. 3.5a.

To download configuration values (DAT file):

- Upon accessing Download Mode the user is given a choice to either quit Download Mode by pressing MENU key or to continue with downloading by pressing SHIFT+SEND keys.
- If the user chooses to press SHIFT+SEND then following screen pulls up:

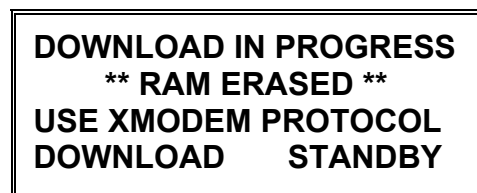

**DOWNLOAD IN PROGRESS
** RAM ERASED **
USE XMODEM PROTOCOL
DOWNLOAD STANDBY**

Fig. 3.5b: Download Mode

- At this time the user must pull up XMODEM protocol on the attached computer and enter the desired file name to start downloading.
- Upon completion of download process the display shows fig. 3.5c. The SS2000 is now fully configured.

**DOWNLOAD COMPLETE
SHIFT+SEND to repeat
MENU to EXIT
DOWNLOAD STANDBY**

Fig. 3.5c: Download Mode

To exit DOWNLOAD Mode:

- Press MENU to exit to MAIN MENU.
- Press SHIFT+MENU to exit to EXTENDED MENU.

Note: User may NOT quit the Download Mode when downloading is in process (i.e., fig. 3.5b is on display).

KEYs and their related actions specific to Download Mode are as follows:

MENU

Exits to Main Menu.

SHIFT+MENU

Exits to Extended Menu.

SHIFT+SEND

Goes to XMODEM receive mode.

3-6. UPLOAD MODE

The SS2000 configuration parameters may be transferred back to a computer attached to the serial port, using UPLOAD mode. Optionally, the configuration parameters may be dumped to a locally attached printer.

The configuration parameters uploads in a standard ASCII format. This may be re-directed to a file with the PC communications package.

The Upload mode is ONLY accessible when the SS2000 is operating in the Standard (s) mode. In other operating modes an attempt to access Upload mode displays ‘Upload Mode Not accessible’ message.

**Press SEND to UPLOAD
Press ‘D’ to DUMP**

UPLOAD STANDBY

Fig. 3.6: Upload Mode

To access UPLOAD mode:

- Press ‘6’ from the EXTENDED MENU. UPLOAD mode appears on the LCD with unit status as STANDBY as shown in fig. 3.6.

To upload the data to the computer screen:

- Pressing SEND while fig. 3.6 is displayed on the LCD uploads the configuration parameters to the computer screen in ASCII format. (Computer screen acts as a DUMB terminal in this case.)

To send the data to the printer:

- Pressing ‘D’ while fig. 3.6 is displayed on the LCD sends the configuration parameters to the locally attached printer.

To exit UPLOAD Mode:

- Press MENU to exit to MAIN MENU.
- Press SHIFT+MENU to exit to EXTENDED MENU.

KEYs and their related actions specific to Upload Mode are as follows:

MENU

Exits to Main Menu.

SHIFT+MENU

Exits to Extended Menu.

SEND

Sends configuration parameters to the serial port in ASCII format.

“D”

Dump configuration parameters to the printer.

3-7. CONFIGURATION PARAMETERS FILE FORMAT:

Configuration Parameter	Optional comment field
12345;.....	password (up to 5 characters)
50; DTMF	on time (35 to 1000msec)
50; DTMF	off time (35 to 1000msec)
100;	front porch time (5 to 9999 msec)
50;	back porch time (5 to 9999 msec)
500;	pause duration (5 to 9999 msec)
* 5;	report time-out (1 to 9999 sec)
* 3;	report attempts (1 to 9)
0;	CD active state(0 or 1)
1;	Use attached printer (0 = no, 1 = yes).
0;	Encrypt outbound DTMF messages.(0=no, 1=yes)
15;	Alarm hour. (0 to 23)
00;	Alarm minute. (0 to 59)
123456;.....	Alarm string. (Up to 64 DTMF digits)
* #001#002#003;	Remote site numbers (for report polling)
* 123?1456;	Report request DTMF string (where “?” will be replaced by the site number).
00;.....	Alarm Interval (0=Daily,1=Weekly,2=Monthly)
00;.....	Alarm Day (1=Sun, 2=Mon, 3=Tue, 4=Wed, 5=Thurs, 6=Fri, 7=Sat)
* 00;.....	Unit ID (01 to 99, for networking only)
* 00;.....	Standard, Map or Computer mode (0=S, 1=M, 2=C)
* 00;.....	Computer LCD (0 = no, 1 = yes)

The SS2000 configuration file may be put together on a computer in the form of an ASCII text file and downloaded serially using XMODEM protocol via RS232 serial connection. Normally, such a file has DAT extension. Though, this is not necessary but recommended to match the Federal’s nomenclature.

DAT file has five sections. **The beginning of each section must be marked by a set of braces { }. Any text that appears between the braces is treated as comments.**

Following explains each section.

```
{
Configuration section
}
```

- The configuration parameters must be listed in the order specified below.
- All parameters must be included, whether used or not.
- Each configuration parameter value must be followed by a semicolon.
- Comments may follow semicolon. Each comment must be followed by a new line.

```
{
    Function key section
}
```

Function key #;	Function key label;	DTMF codes;	Optional comments
1;	Tornado;	1234567890;	Tornado warning
2;	Function key 2;	2222222;	codes for F02
3;	Function key 3;	3333333;	codes for F03
4;	Function key 4;	4444444;	codes for F04

- There are four distinct fields.
- Each field is terminated by a semicolon.
- Comment field is followed by a new line character.

Function key # is a decimal number from 1 to 18, indicating the function key on the SS2000 where the associated DTMF code is intended to go. Followed by a semicolon

Function key label could be up to 16 ASCII characters followed by a semicolon.

DTMF Codes up to a 64 character DTMF string followed by a semicolon.

Optional comments optional text followed by a new line.

```
{
*Report Message Section (Used in
two-way systems only)
}
```

There are no user programmable options in this section. This section can only be modified by Federal Signal's Applications Engineers. The User must NOT change this section when creating a custom DAT file.

```
{
  FCT/UCT function report section
}
```

Function number;	Function Description;	Comments
1;	Function 1;	Optional comment field
2;	Function 2;	
3;	Function 3;	
4;	Function 4;	
5;	Function 5;	
6;	Function 6;	

- **Function number** 1-6 represents 6 FC functions. Field terminated by semicolon.
- **Function description** Could be 16 characters long. User can customize the function description. Field terminated by semicolon.
- **Comment field** (Optional) Field terminated by new line.

51;51; 52;52; 53;53; 54;54; 55;55;
 56;56; 57;57; 58;58; 59;59; 60;60;
 61;61; 62;62; 63;63; 64;64; 65;65;
 66;66; 67;67; 68;68; 69;69; 70;70;
 71;71; 72;72; 73;73; 74;74; 75;75;
 76;76; 77;77; 78;78; 79;79; 80;80;
 81;81; 82;82; 83;83; 84;84; 85;85;
 86;86; 87;87; 88;88; 89;89; 90;90;
 91;91; 92;92; 93;93; 94;94; 95;95;
 96;96; 97;97; 98;98; 99;99; 100;100;

```
{
  SirenSite#;MapLed#
  (Used for Map (m) and Computer© modes )
}
```

1;1; 2;2; 3;3; 4;4; 5;5; 6;6; 7;7;
 8;8; 9;9; 10;10;
 11;11; 12;12; 13;13; 14;14; 15;15;
 16;16; 17;17; 18;18; 19;19; 20;20;
 21;21; 22;22; 23;23; 24;24; 25;25;
 26;26; 27;27; 28;28; 29;29; 30;30;
 31;31; 32;32; 33;33; 34;34; 35;35;
 36;36; 37;37; 38;38; 39;39; 40;40;
 41;41; 42;42; 43;43; 44;44; 45;45;
 46;46; 47;47; 48;48; 49;49; 50;50;

Format: Actual siren site number; corresponding map led number; Maximum 100 sites can be programmed.

The configuration file (.DAT file) should have a pair of braces at the end of the file to mark the termination of the file.

```
{
  end of report section
}
```

SECTION IV INSTALLATION

-Caution-

Installation must be performed by an experienced technician in accordance with national, state, and any other electrical codes having jurisdiction.

4.1 General

- The SS2000 features a balanced 600 ohm input and output (optionally set to 10K ohms).
- Relay outputs control Audio output, PTT, MIC disconnect, and a spare contact.
- Both N.O. and N.C. contacts are available.
- Carrier Detect can be active High (4 -14v) or Low (0 - 3.0v). This input is optionally pulled to 10 VDC through a 470k resistor or to ground through a 690k resistance.
- An optional VOX circuit can be used if a C.D. output is not available. The VOX logic is derived from the Audio input line voltage and should only be used when it is not possible to get a true C.D. signal.

4.2 Connections and adjustments

Make electrical connections as shown in the figure below. If the radio does not have balanced inputs and outputs, the AUDIO OUT LO, RX LO and PTT COM can all be connected together at the radio ground.

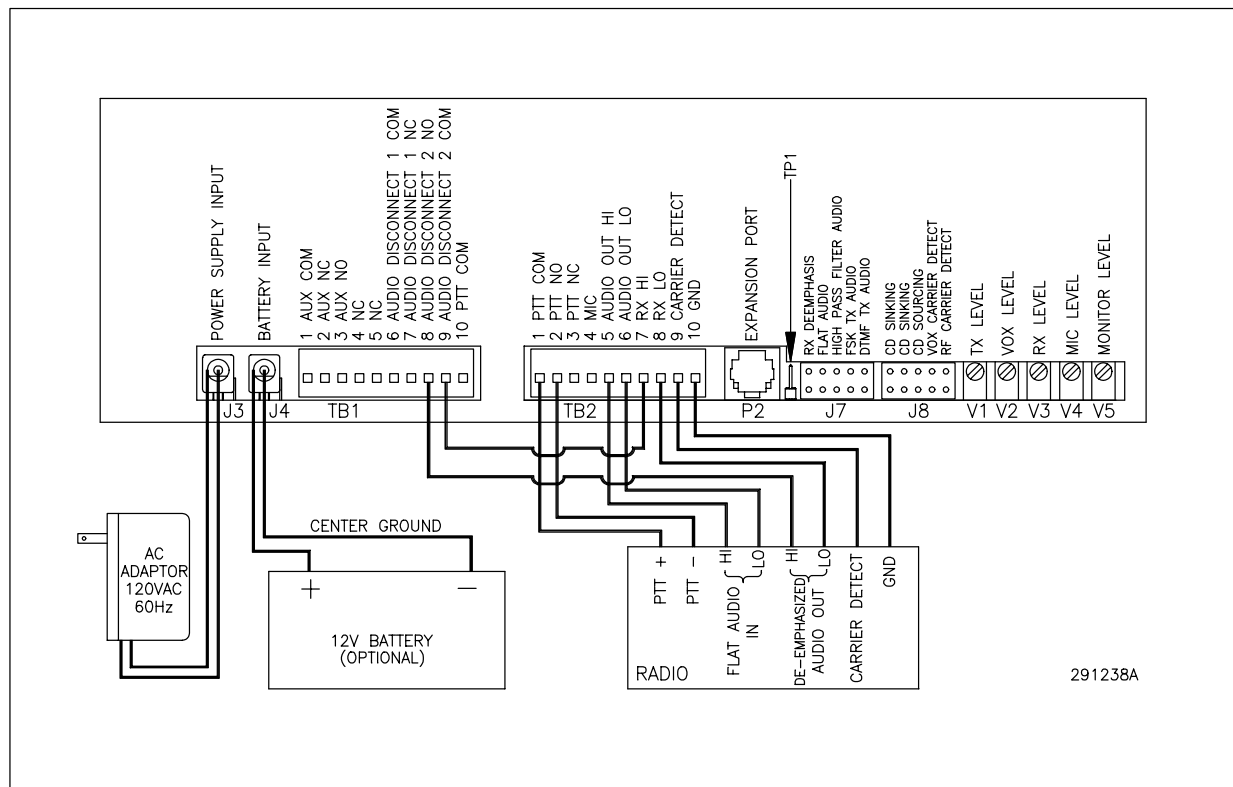

Fig. 4.1: Installation and connection diagram

Input/Output Impedance Selection

If the SS2000 is connected to a high impedance audio system, remove the jumpers at JU1 and JU2 on the 2001176 PC board to select a 10K impedance.

The jumper at JU2 can also be removed to obtain a lower voltage from radios with high audio voltage level output. The cover of the SS2000 must be removed to access JU1 & JU2.

Carrier Detect (C.D.) Setup

C.D. can either be connected directly from a radio transceiver, or it can be derived from the TX audio level. Jumpers at J8 determine how C.D. operates. Refer to section 3-3 if the polarity of the C.D. signal must be changed.

When connecting directly to a radio transceiver, set the jumper on J8 as shown below.

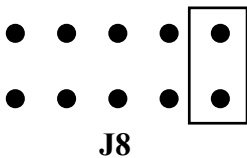

Carrier Detect (Sourcing) Selection

If the carrier detect signal is a high and low going voltage source, apply a jumper as shown below.

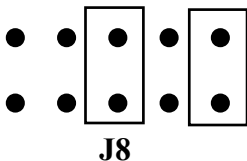

Carrier Detect (Sinking) Selection

If the carrier detect signal is provided by an open collector or relay contact, apply jumpers to J8 as shown below.

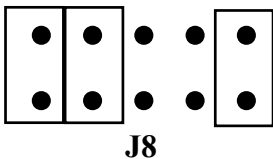

-Caution-

Never place jumpers on J8 as shown below. This will make the SS2000 inoperable.

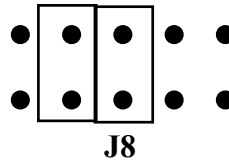

When a Direct Transceiver C.D. connection is not possible, set the jumpers on J8 as shown below to enable the VOX circuit.

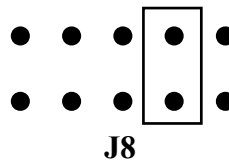

When this setting is used, V2 is used to adjust the audio level required to detect C.D.. NOTE: This level should not be set until the RX audio level is set (2-way systems only).

DTMF Transmit level (TX)

V1 adjusts the DTMF output level. This level should be set for a 3-3.3 KHz deviation output from the transmitter. Refer to section 3-4 for the calibration mode instructions.

DTMF Receive Level (RX)

V3 Adjusts DTMF receive level. Adjust V3 for a 100mv - 1volt peak-peak (or 250mV RMS) level at J7-9 or TP1. Refer to the input/output impedance selection at the beginning of this section if the voltage cannot be adjusted down to the proper level.

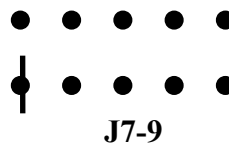

Flat Audio Selection

If private line coding (CTCSS or DPL) is NOT being used, the flat audio path should be selected as shown below.

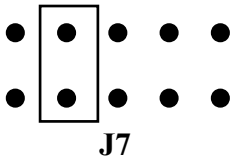

Do not place jumpers to connect the high pass filtered audio and the flat audio at the same time. See the following High Pass Filtered Audio Selection.

High Pass Filtered Audio Selection

If private line coding (CTCSS or DPL) is being used, the high pass filtered audio line should be selected as shown below.

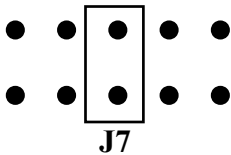

Do not place a jumper in the flat receive audio position when the high pass filtered audio is selected.

RX De-emphasis Selection

If de-emphasis is required on the receive audio signal, select de-emphasis as shown below.

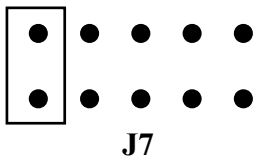

Monitor Speaker Level

Adjust V5 for the desired volume setting.

Use the Calibration Mode to generate audio without activating the system.

MIC Level

Adjust V4 for the desired audio level. If using a radio system, this level is typically set for 4khz of deviation.

4.3 SS-REMOTE Installation:

- Make sure the power is off to the SS2000 and the SS-REMOTE units.
- Connect the SS-REMOTE unit to the SS2000 via six line I²C cable. (i.e., connect one end of the I²C cable to the phone jack (P2) on the SS2000 and the other end of the I²C cable to the phone jack (P1) on the SS-REMOTE.)
- Connect the needed remote land-line contacts into the jacks (J1-J4) provided at the SS-REMOTE.
- Connect the power to the SS2000. Wait until MAIN MENU becomes visible on the SS2000 LCD before turning power on to the SS-REMOTE.

Closing any of the remote contacts will now trigger the associated function on the SS2000.

Note: The SS-REMOTE will only work with the software revisions 2.0 or above. (Turn the key lock to off position to check the software revision number that is loaded.) If initially the software revision is lower than 2.0 than the user must cut pin 13 of U4 on the power supply board (#2001176).

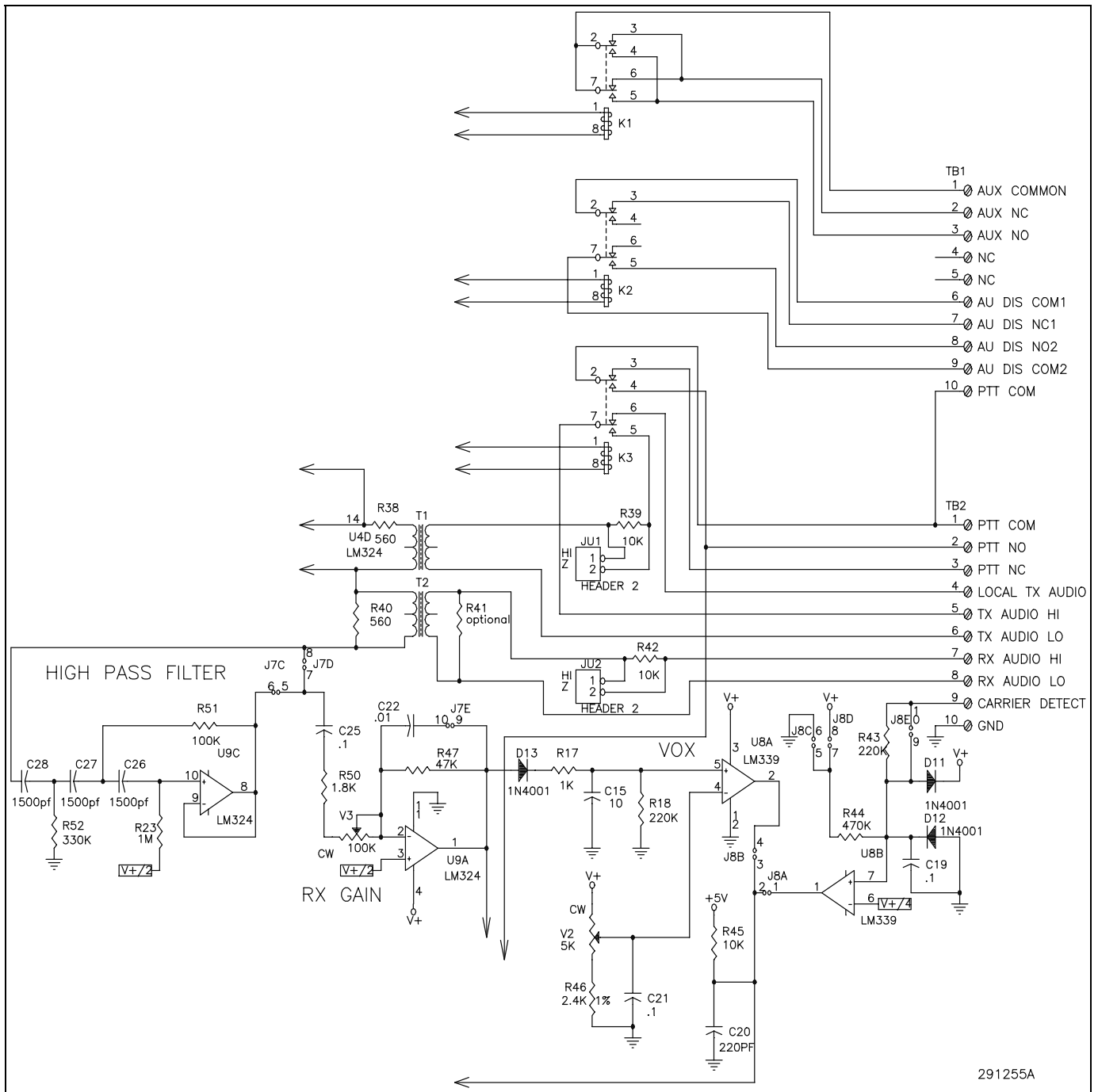

Fig. 4.2: I/O Schematic

SECTION V

TESTING

5.1 SELF TEST FEATURE

The SS2000 SelfTest is a software controlled testing procedure which helps to ensure that the unit is functioning properly and is ready for use. There are 6 functions or parts of the SS2000 that can be tested with the Self Test. They are as follows:

1. LCD display
2. LEDs and Buzzer
3. Keypad and Function keys
4. Relays 1, 2, and 3
5. DTMF Receive and Transmit
6. FSK Receive and Transmit

The SelfTest does not acknowledge a defect. The test works by comparing actual results with expected results to determine if a problem exists. If any of the actual results differ from the expected result then the unit is defective and needs a fix.

Self Test results can be printed on the attached printer, if printer option is enabled in CONFIG mode.

To access SELF TEST:

- Reset the SS2000.
- There are two ways to reset the unit.
 1. Depressing the reset button, which is located on the CPU board.
 2. Turning off the unit and then back on. (This may be

accomplished by removing and inserting the power cord at the back of the unit.)

- As the unit powers up following a reset the LCD back light comes on and the LCD becomes blank with a little click.
- From this moment of time, within 3 seconds press SHIFT+SEND, while the LCD is still blank.
- If correct sequence is followed with proper timings the SS2000 boots up in SelfTest mode with SelfTest menu on display as shown in fig. 5.1.

1. LCD	2. LED
3. KEYS	4. RELAY
5. DTMF	6. LOOP
7. FSK	8. QUIT

Fig. 5.1: Self Test Menu

To run the tests:

- To do a particular test press the number corresponding to it.
- To perform all tests in a sequential manner, press 6 (LOOP option).
- Pressing MENU from any test aborts that test and switches back to SELF TEST menu. In LOOP mode (#6) MENU press switches to the next test.

To exit SELF TEST:

- From the SELF TEST menu press either of the following to quit Self Test and to enter the MAIN MENU:
 - 8 (QUIT option)
 - SHIFT + SEND

Following sections describes each test in detail.

5.2 TEST 1 - LCD

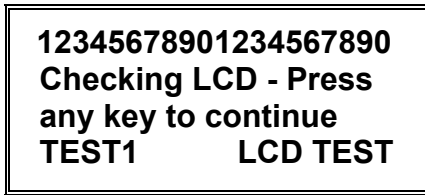

Fig. 5.2: TEST 1 - LCD

Item tested:

Ability of the LCD module to display 4 lines and 20 characters.

Expected results:

The SS2000 LCD should be identical to fig. 5.2.

To exit:

Press any key.

5.3 TEST 2 - LED

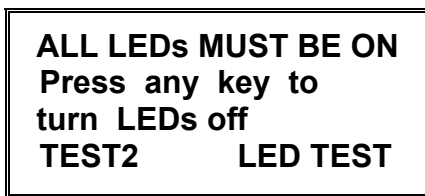

Fig. 5.3: TEST 2 - LED

Item tested:

All four LEDs and piezo buzzer.

Expected results:

All four LEDs must turn on and

piezo buzzer must sound.

To exit:

Press any key.

5.4 TEST 3 - KEYS

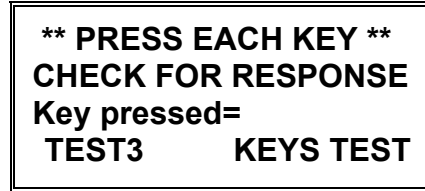

Fig. 5.4: TEST 3 - KEYS

Item tested:

All 30 keys on the SS2000 unit.

Expected results:

Each key press must display associated character on the LCD. Following is a list of keys and associated characters. Verify each key press with the list.

Key press LCD display.

1	1
2	2
3	3
4	4
5	5
6	6
7	7
8	8
9	9
0	0
A	A
B	B
C	C
D	D
*	*
#	#
F1	F01
F2	F02
F3	F03
F4	F04
F5	F05

F6	F06
F7	F07
F8	F08
F6	F06
F7	F07
F8	F08
F9	F09
F10	F10
F11	F11
F12	F12
F13	F13
F14	F14
F15	F15
F16	F16
F17	F17
F18	F18
SHIFT+F17	F19
SHIFT+F18	F20
CLEAR	<--
SHIFT+MENU	M
SHIFT+SEND	S
SHIFT+CLEAR	k
SHIFT+1	,
SHIFT+2	.
SHIFT+3	?
SHIFT+A	=
SHIFT+C	c
SHIFT+*	+
SHIFT+#	-
MENU	MENU key is used to exit the key test.

To exit:
Press any key.

5.5 TEST 4 - RELAY

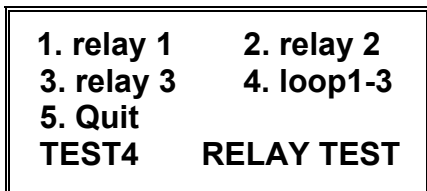

Fig. 5.5a: TEST 4 - RELAY

Item tested:

Relays 1,2 and 3.

NOTE: An OHM meter or a continuity tester is needed for the test.

Procedure:

- Connect the meter or continuity tester leads to the relay contacts (Refer to chart below and to figure 5.5b).

Relay #	Lead connections
1	TB1-1, TB1-3
2	TB1-9, TB1-8
3	TB1-10, TB2-2

The meter reading should be infinite, indicating an open circuit.

Set the meter to a 10 Ohm scale.

- Press '1' to activate relay 1.

The meter reading should be no greater than 0.75 Ohms, indicating a closed circuit.

- Press '1' to deactivate relay 1.

The meter reading should again be infinite. Repeat the same procedure for relays 2 and 3.

- Option 4 is a loop test used to test all the relays in sequentially.

To exit: Press any key.

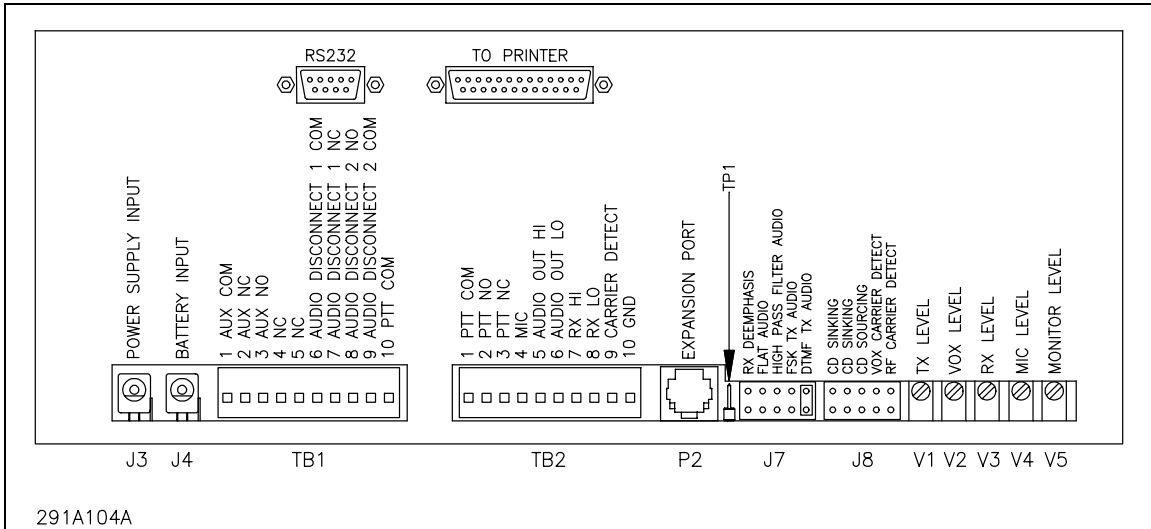

Fig. 5.5b

5.6 TEST 5 - DTMF

Enter DTMF code
Enter Code - SEND
Press SEND to begin

Fig. 5.6a: TEST 5 - DTMF

Item tested:
 DTMF transmit and receive functions.

Procedure:

- Connect TB1 and TB2 as shown in figure 5.6b

***NOTE:** Remove power from the unit before making any connections.*

- Enter a DTMF code and press SEND.

Expected results:

- The transmitted and received code displays on the LCD. They should be identical.
- Press the SEND key twice to re-send the code.
- Press CLEAR twice to clear the code.
- Press MENU twice to exit.

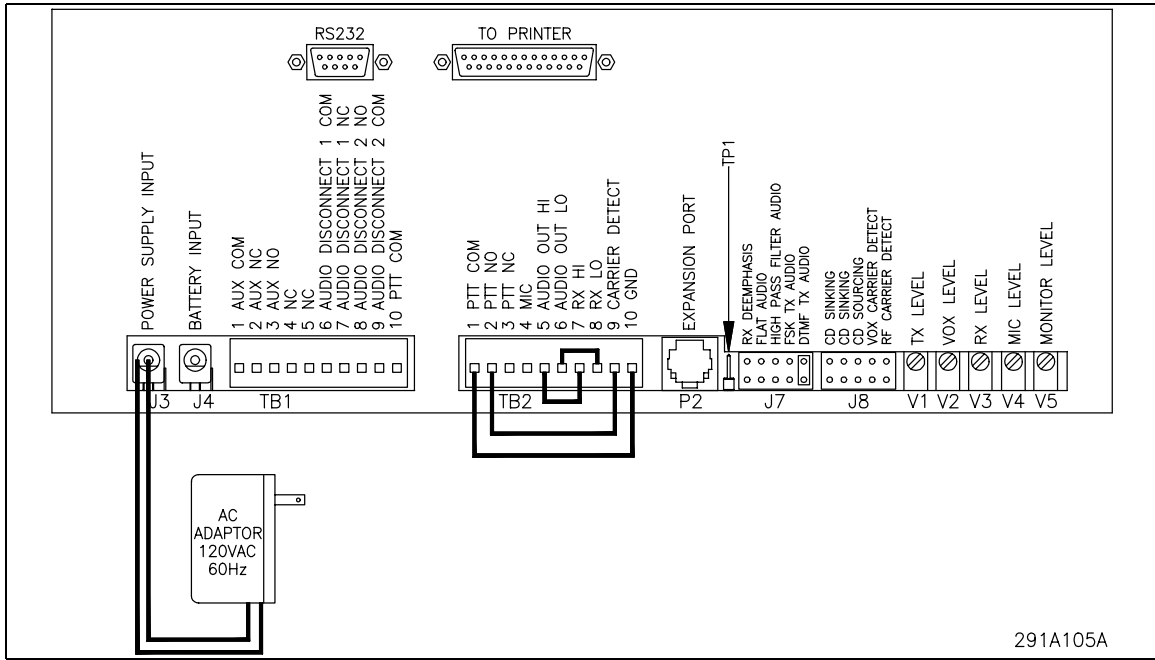

Fig. 5.6b

5.7 TEST 6 - FSK (Not applicable)

FSK MODE TEST
Press any key....
Press MENU to quit

Fig. 5.7: TEST 6 - FSK

Item tested:

FSK transmit and receive function.

Procedure:

- Place a jumper at J3B (J3 pin 3-4)
- Press any digit.

Expected Result:

The digit is transmitted, received and displayed on the LCD.

To exit:

Press MENU key .

SECTION VI

PERIPHERALS

6.1 SS-REMOTE

SS-REMOTE is the peripheral unit that provides a land line interface to the SS2000 using remote contacts. Software revision 1.8 or greater is needed in the SS2000 for this enhanced capability. Key features of the SS-REMOTE are:

- Communicates with the SS2000 over I²C bus.
- Isolated power supply. (12 volts to 22 volts dc.)
- 20 opto isolated inputs for protection against induced voltage spikes and ESD.
- Remote cable length up to 30,000 feet is possible (500 ohms as permissible resistance).
- Maximum remote wire gauge that can be used is 12.
- Additional space of 2.00 inches is needed below the SS2000 (rack mount) for SS-REMOTE unit.
- SS-REMOTE activation **will bypass the key lock** on the SS2000.
- SS-REMOTE activation will abort the report mode on the SS2000 (if the SS2000 is in the report mode).
- The SS2000 will have the DTMF transmit priority over the SS-REMOTE if it is in transmit mode.
- Make sure the power is off to the SS2000 and the SS-REMOTE units.
- Connect the SS-REMOTE unit to the SS2000 via six line I²C cable. (i.e., Connect one end of the I²C cable to the phone jack (P2) on the SS2000 and the other end of the I²C cable to the phone jack (P1) on the SS-REMOTE.)
- Connect all needed remote land line contacts into the connectors (F1-F20) provide at the SS-REMOTE unit.
- Connect the power to the SS2000. Wait until MAIN MENU becomes visible on the SS2000 LCD before turning the power on to the SS-REMOTE.
- Any remote contact closure can now trigger the associated function on the SS2000.
- Debounce time for remote key press is 250 msec.
- A key depressed for extended time will **not** generate multiple key entries.
- A key held depressed will not allow new key presses.

Operating Procedure: (Refer to fig. 6-1 for connections.)

Programming Instructions:
 There are no SEND or CLEAR keys provided at the remote inputs. However, the software allows the user to program SEND and CLEAR keys within the function as a part of the string to be transmitted.

Programming CLEAR key:

Pressing SHIFT + CLEAR, while entering the DTMF string in the PROGRAM MODE, displays a 'k' on the LCD representing a CLEAR key. It is recommended that:

- CLEAR key be programmed only at the beginning of the string.
- All remotely activated functions

begin with the CLEAR (k) key, unless sequential stacked functions are required.

Programming SEND key:

Pressing SHIFT + SEND, while entering the DTMF string in the PROGRAM MODE, displays an 'S' on the LCD representing a SEND key. It is recommended that:

- SEND key be programmed only at the end of the string.
- All remotely activated functions end with the SEND (S) key.

6.2 SSWIN is a Windows^R 95/98 graphical users interface used to configure the SS2000D.

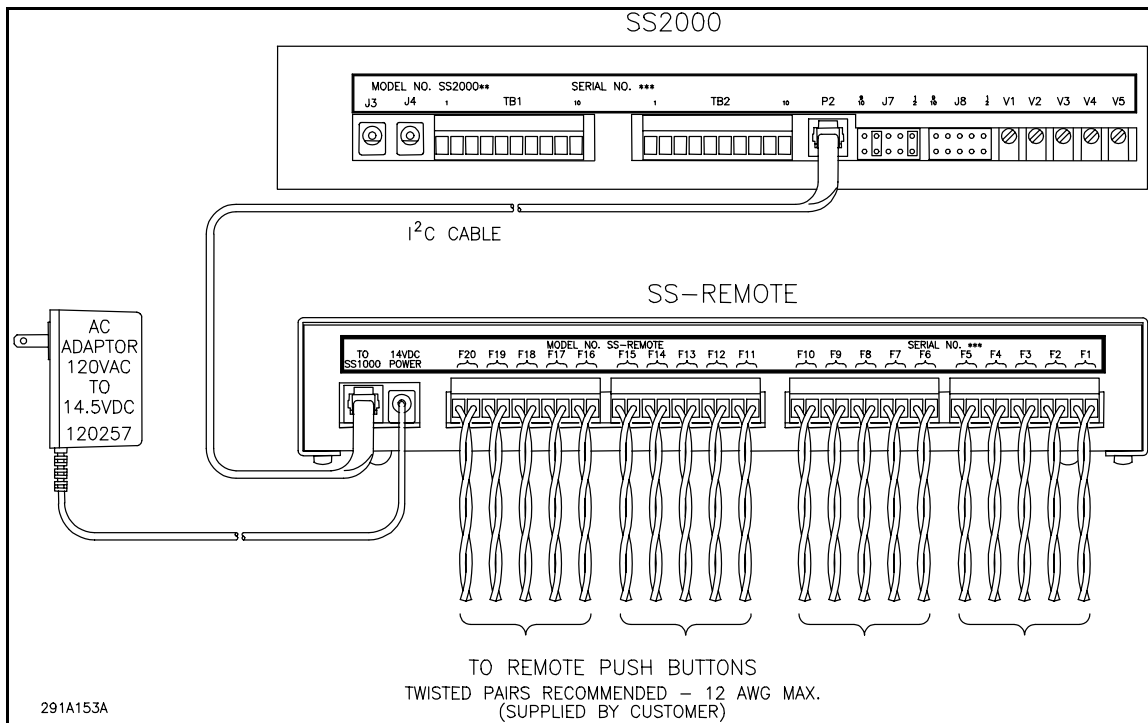
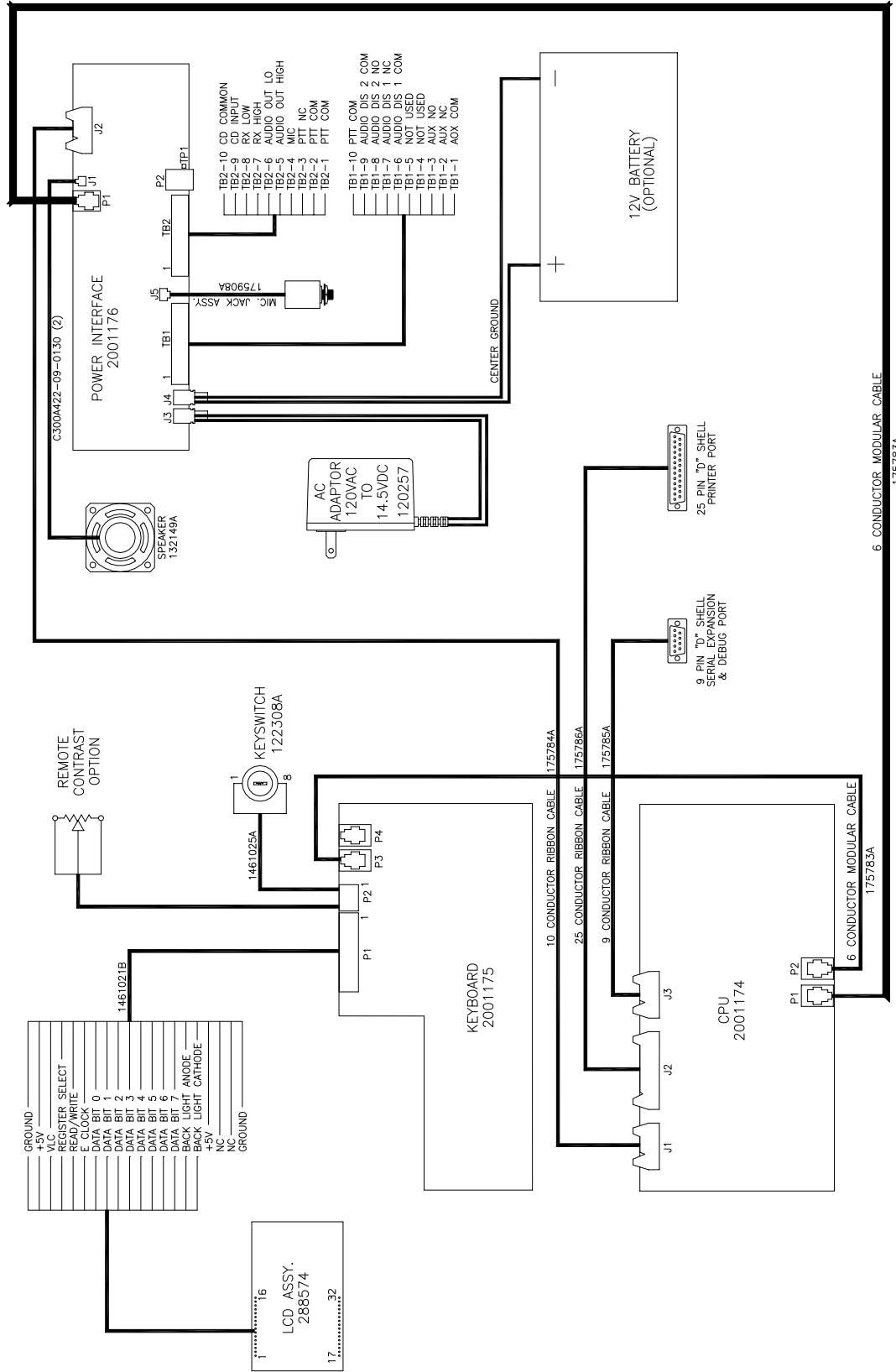

Fig. 6.1



SS2000D Wiring Diagram

291180E

SECTION VII ADDENDUM

There are currently no addendums to this manual.

SS2000 Series
CONTROLLER/ENCODER

SS2000

SS2000R

SS2000T

SS2000TR

INSTALLATION AND OPERATION INSTRUCTIONS



FEDERAL SIGNAL CORPORATION

2645 Federal Signal Drive, University Park, IL 60466

Phone: (708) 534-3400 FAX: (708) 534-4855