



MICROPROCESSOR-BASED CONTROL SYSTEM FOR HIGH-POWER ELECTRONIC SPEAKER ARRAYS

- One- or two-way siren control
- Status monitoring
- Seven warning tones
- Public address
- Digital pre-recorded voice messages
- Landline, Ethernet (IP) or Radio Control
- Pole or wall mount
- Type 4 or optional 4X enclosure
- UL and cUL Listed

UltraVoice™ Electronic Siren Controller

Model UV

The Federal Signal UltraVoice™ is designed to provide one- or two-way control of high-power electronic sirens such as the MOD or DSA, or to control indoor AudioMaster speaker systems. UltraVoice produces amplified audio signals including seven built-in warning tones, high-quality live public address, and pre-recorded voice messages.

The UltraVoice is housed in two cabinets. The control cabinet houses the control module and amplifiers. A separate vented cabinet houses the batteries. The standard cabinet for the UltraVoice is made from 5052-H32 grade aluminum. This control cabinet is also available in 304 or 316 stainless steel. The number of amplifiers and batteries (purchased separately) required by an UltraVoice Controller depends on the power required by the specific siren array or speaker system.

Two-way systems provide siren status to the control station and include a sensor package, radio transceiver and encoder/decoder. Computer controlled status monitoring of the following conditions is provided: AC Power, Battery Voltage, Charger Operation, Activation Current, Signal Line A and B, Mode of Operation, Quiet Test, Intrusion, and Local Activation.

Options

UltraVoice units may be equipped with a programmable RF receiver for remote control using MSK, DTMF or Two-tone Sequential protocols. Pre-recorded digital voice messages can be added by simply plugging in a four- or eight-minute IC chip. Windows®-based software is available that allows users to configure activation sequences.

ULTRAVOICE™ ELECTRONIC SIREN CONTROLLER

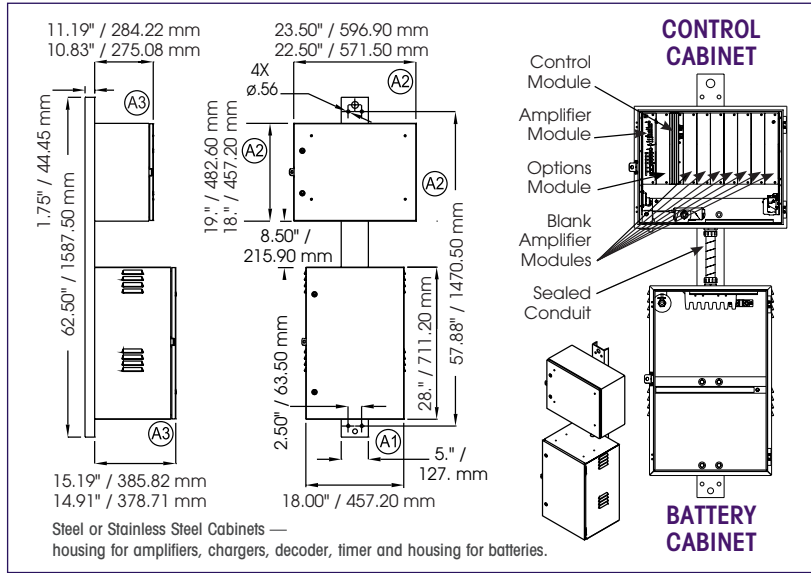

SPECIFICATIONS

Power

| | |
|----------------------------|--|
| Input Voltage: | 120/240±10%, 50/60Hz VAC single-phase |
| Input Current: | 7 A Max. |
| Operating Voltage: | 24VDC |
| Standby Current: | |
| UV | 100mA DC |
| UVT | 600mA DC |
| Standby Time: | > 7 days |
| Continuous Signaling Time: | 30 min. |

Control Module

| | |
|-------------------------------|--------|
| Signal Duration (auto reset): | 3 min. |
|-------------------------------|--------|

Microphone

| | |
|------------------------|--------------------|
| Input Impedance: | 10k ohms |
| Audio Distortion: | 1% THD max. |
| Maximum Load: | 600 ohms |
| Contact Closure: (min) | 500 ms < 1.0k ohms |

Amplifier Module

| | |
|-------------------------------|---------------------------------|
| Frequency Response: | (300 to 3 kHz) ±3dB (ref. 1kHz) |
| Output Voltage (Tone and PA): | (to speaker drivers) 70 Vrms |
| Input Impedance: | (per amplifier) 100k ohms |

General

| | |
|--------------------------|-----------------------------------|
| Operating Temperature**: | -22°F to 149°F -30°C to 65°C |
| Enclosures: | |
| Control Cabinet: | Type 4 or 4X |
| Battery Cabinet: | Type 4 (vented) |

** The siren can operate throughout this temperature range provided the battery temperature is maintained at 0°F/-18°C or higher.

HOW TO ORDER

Contact our Federal Signal Sales Engineers to design a system that meets your specific requirements. Considerations for system configuration:

- Specify Model Number –
 - UV – Controller, One-way
 - UVTD – Controller, Two-way Digital with Radio Control Options
 - UVTD-IP – Controller, IP-Enabled
 - UVTD-LL – Controller, Landline
- Specify Radio Control Requirements –
 - One-way or Two-way; Low Band, High Band, UHF and Private Line
- Specify Protocol – DTMF, MSK, Two-tone
- Specify Radio Frequency
- Specify Number of 400 Watt Amplifiers Required (Model UV400)
- Specify Accessories –
 - Digital Voice Chips, 8 Minutes
 - Customized Tones Available per Quote
 - Solar Charging System
 - FS-MWIN – Windows® Programming Software (Two-tone and DTMF)
 - Antenna – SS2000 Encoder
 - Stainless Steel or Aluminum Cabinets – HTR2 or HTR4 Battery Heaters
 - Commander – Two-way Digital Programming and Control Software
 - MNC-MC – Microphone
 - TB-LL – Telco Base, Landline

STANDARD TONES

| <u>Tone</u> | <u>A/B Tone Frequency Range</u> | <u>Sweep Rate (seconds)</u> |
|------------------|---------------------------------|-----------------------------|
| Wail | 400/480-850/1020 | 13.0 |
| Pulsed Wail | 400/480-850/1020 | 1.5 /13.0 |
| Alternate Wail | 400/480-850/1020 | 1.5/13.0 |
| Steady | 850/1020 | N/A |
| Pulsed Steady | 850/1020 | 1.5 |
| Alternate Steady | 850/1020 | 1.5 |

BATTERY REQUIREMENTS

- Customer must provide necessary batteries. Call for assistance with specific system requirements.