

Advanced security and well-being

**8) Testing unit operation**

The breakglass unit can be tested without the need to break/replace the frangible glass element. A test key (7mm Allen key) is used to mechanically drop the glass down activating the switch.

The test key is inserted in the test cam and rotated clockwise by an angle of 60° the glass element will visibly drop down in the viewable window.

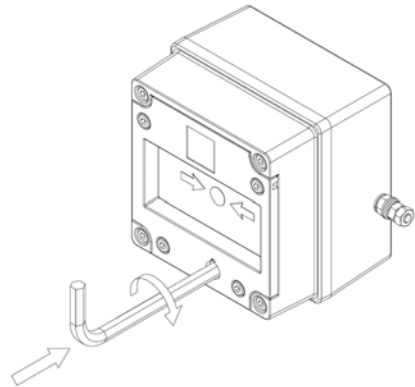

The call point switch will now change over its contacts to operate the alarm.

Once testing is complete the unit needs to be reset, the test key is rotated back anticlockwise by an angle of 60° back to its original position. The glass element should now raise up so it is level again in the viewable window.

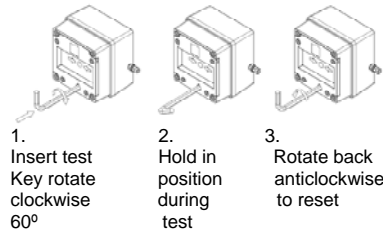

**9) Replacement of glass element**

If the breakglass unit has been operated the broken glass element can be quickly replaced.

The breakglass cover plate is removed by unscrewing the 4 off M4 cap head screws attaching it.

Once cover is removed the broken glass will be free to be removed, clean out any other fragments of glass carefully.

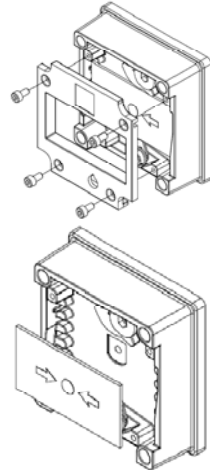

To fit the new glass element rotate the top cam clockwise by an angle of 50° (use a 6mm Allen key) this will then allow the glass to fit back into the pocket it sits in, resting on the pivot point and test cam, release the top cam to rest on the top of the glass element.

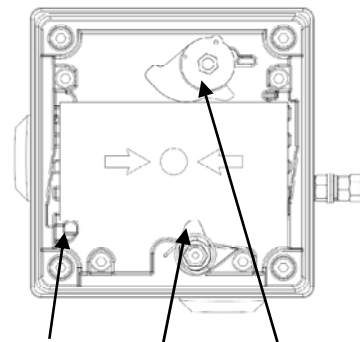

Pivot point Test Cam Top Cam (rotate)

Zones 1 and 2 with flammable gases and vapours with gas groups IIA, IIB & IIC and temperature

**INSTRUCTION MANUAL**  
**WCP-BG-XXX Breakglass Manual Call Point**  
**For use in Flammable Gas and Dust Atmospheres**

II, EPL Db. The T70°C Db' and as 21 and 22 for B & IIC.

the units test operation. See section 8 of this instruction manual.

**WCP-BG-XXX**  
**Manual Call Point – Breakglass**  
**With Resistor Modules**  
**For use in Flammable Gas and Combustible Dust Atmospheres.**

**2) Marking**

All units have a rating label, which carries the following important information:-

Unit Type No.:  
WCP-BG-XXX Manual Call Point

Input Voltages:  
48VDC nominal 56VDC Max 0.75Amax  
24VDC nominal 28VDC Max 1.0A Max  
12VDC nominal 15VDC Max 1.0A Max  
6VDC nominal 9VDC Max 1.0A Max

Code:  
Ex e d mb IIC T4 Gb  
Ex t IIIC T70 °C Db  
IP66  
-40°C <= Ta <= +50°C

Certificate No.:  
SIRA 10ATEX3103X  
IECEX SIR 10.0047X

Epsilon x: II 2GD

CE Marking  
Notified body No. 0539

Year/Serial No. i.e. 10/9CP3BBG000001

**WARNING - DO NOT OPEN WHEN AN EXPLOSIVE ATMOSPHERE MAY BE PRESENT**

**3) Type Approval Standards**

The beacon has an EC Type examination certificate issued by SIRA and have been approved to the following standards:-

IEC 60079-0:2007  
EN 60079-1:2004 / IEC 60079-1:2003  
EN 60079-7:2007 / IEC 60079-7:2006  
IEC 60079-18:2009

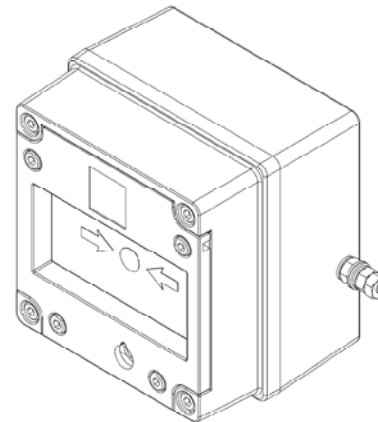

**1) Introduction**

The WCP-BG-XXX is a breakglass manual call point which is certified to the European and International Gas and Dust standards. The unit meets the requirements of the ATEX directive 94/9/EC and IECEx scheme.

The call point can be used in hazardous areas where potentially flammable gas and dust atmospheres may be present.

The WCP-BG-XXX has up to two monitoring resistors. The units are Group II, EPL (equipment protection level) Gb. The equipment is certified 'Ex e d mb IIC T4 Gb' and as such may be used in

EN 61241-1:2004 / IEC 61241-1:2004

The equipment is certified for use in ambient temperatures in the range -40°C to +50°C and shall not be used outside this range.

#### 4) Installation Requirements

Installation of this equipment shall only be carried out by suitably trained personnel in accordance with the applicable code of practice e.g. IEC 60079-14/EN 60079-14 and IEC 61241-14/EN 61241-14.

Repair of this equipment shall only be carried out by the manufacturer or in accordance with the applicable code of practice e.g. IEC 60079-19/EN 60079-19.

The certification of this equipment relies on the following materials used in its construction:

Enclosure: Aluminium Pressure Die Cast Body LM6

Through enclosure mechanism: Plastic Nylon Zytel Injection Moulded

Sealing of enclosure and mechanism: O-ring Acrylonitrile-Butadiene Rubber

Potting Compound of resistors where used: Epoxy Resin

If the equipment is likely to come into contact with aggressive substances, then it is the responsibility of the user to take suitable precautions that prevent it from being adversely affected, thus ensuring that the type of protection is not compromised.

"Aggressive substances" - e.g. acidic liquids or gases that may attack metals, or solvents that may affect polymeric materials.

"Suitable precautions" - e.g. regular checks as part of routine inspections or establishing from the material's data sheet that it is resistant to specific chemicals.

Refer to certificates SIRA 10ATEX3103X and IECEx SIR 10.0047X for special conditions of safe use.

#### 5) Call Point Location and Mounting

The location of the call point should enable ease of access for operation and testing. The unit should be mounted using the 4 off fixing holes which will accept up to M4 sized fixings.

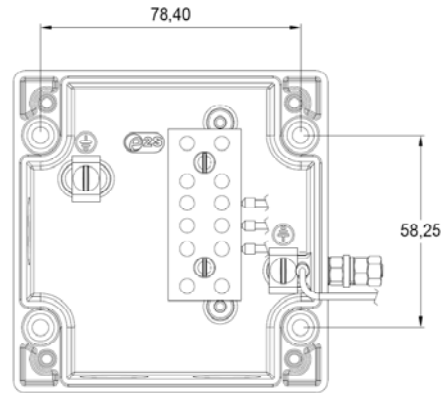

View of base unit showing fixing centres.

To gain access to the mounting holes in the base the front cover must be removed. This is achieved by removing the 4 off M4 cap head bolts holding on the cover.

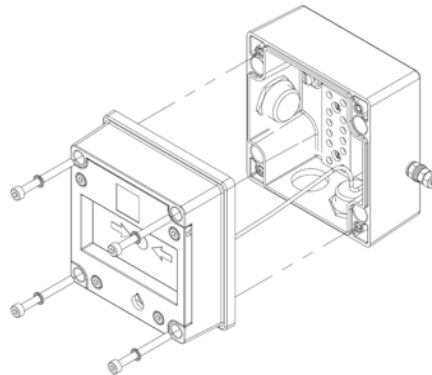

Once the screws are removed the cover will hang down out of the way to gain access to the Ex e

terminal block, the internal earth terminal and mounting hole recesses.

#### 6) Earthing

The unit has both internal and external earth terminals.

It is recommended that a cable crimp lug is used on the earth wires.

The internal earth wire is placed under a earth clamp which will stop the cable twisting. This is secured by an M4 screw and spring washer.

The external earth lug should be located between the two M5 washers provided and securely locked down with the M5 spring washer and two locknuts.

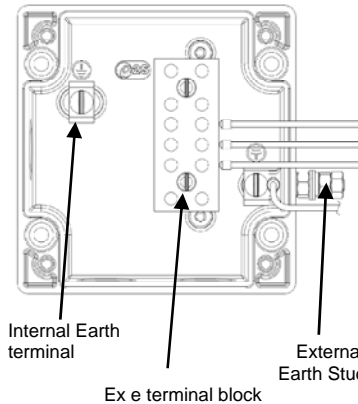

#### 7) Cable connections

There are 3 off cable entries for M20x1.5 Ex e approved cable glands or stopping plugs

The unit can be wired in a number of different ways depending on the resistor combination selected.

Option 1 – In line resistor R1

Option 2 – End of line resistor R2

Option 3 – In line and end of line resistors R1 & R2

Note:- The maximum voltage stated must not be exceeded, as the internal resistor modules are rated as compliant with Ex mb according to the units voltage

When wiring to Increased Safety terminal enclosures, you are only permitted to connect one wire into each way on the terminal block, unless a pair of wires are crimped into a suitable ferrule.

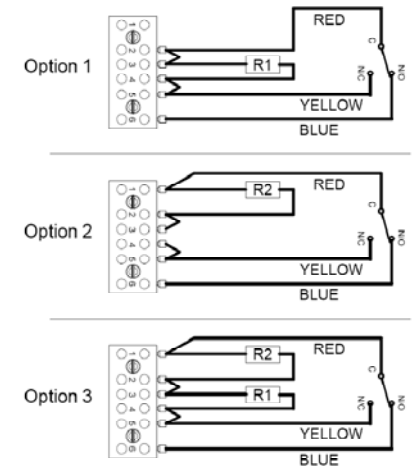

Unit in 'Standby condition' unoperated  
Terminals (2,3) & (6) switch contacts closed  
Terminals (2,3) & (4,5) switch contacts open

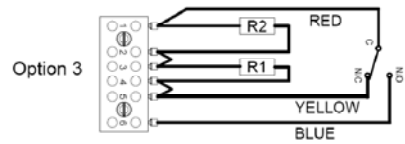
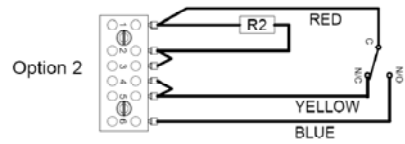
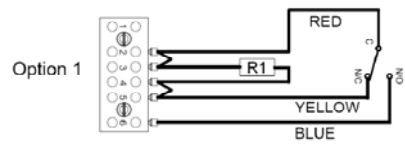

**Unit in 'Operated condition' (broken glass)**  
 microswitch contacts changed over  
 Terminals (2,3) & (6) switch contacts open  
 Terminals (2,3) & (4,5) switch contacts closed