



120 Series
Loudspeaker, ISMT Loudspeaker,
Powered Loudspeaker, and Sounder
25 Watts
(Model Type ES4 and ES5)



***Installation, Operation,
and Maintenance***



Warranty – Seller warrants all goods for five years on parts and 2-1/2 years on labor, under the following conditions and exceptions: Seller warrants that all goods of Seller's manufacture will conform to any descriptions thereof for specifications which are expressly made a part of this sales contract and at the time of sale by Seller such goods shall be commercially free from defects in material or workmanship. Seller reserves the right at the Seller's discretion to "Repair and Return" or "Replace" any item deemed defective during the warranty period. This warranty does not cover travel expenses, the cost of specialized equipment for gaining access to the product, or labor charges for removal and reinstallation of the product. This warranty shall be ineffective and shall not apply to goods that have been subjected to misuse, neglect, accident, damage, improper maintenance, or to goods altered or repaired by anyone other than Seller or its authorized representative, or if five years have elapsed from the date of shipment of the goods by Seller with the following exceptions: lamps and strobe tubes are not covered under this warranty. Outdoor warning sirens and controllers manufactured by Federal Warning Systems are warranted for two years on parts and one year on labor. No agent, employee, representative or distributor of Seller has any authority to bind the Seller to any representation, affirmation, or warranty concerning the goods and any such representation, affirmation or warranty shall not be deemed to have become a part of the basics of the sales contract and shall be unenforceable. THE FOREGOING WARRANTIES ARE EXCLUSIVE AND IN LIEU OF ALL OTHER WARRANTIES OR MERCHANTABILITY, FITNESS FOR PURPOSE AND OF ANY OTHER TYPE, WHETHER EXPRESS OR IMPLIED. These warranties shall not apply unless Seller shall be given reasonable opportunity to investigate all claims for allegedly defective goods. Upon Seller's instruction a sample only of allegedly defective goods shall be returned to Seller for its inspection and approval. The basis of all claims for alleged defects in the goods not discoverable upon reasonable inspection thereof pursuant to paragraph 8 hereof must be fully explained in writing and received by Seller within thirty days after Buyer learns of the defect or such claim shall be deemed waived.



Federal Signal Corporation
Integrated Systems
2645 Federal Signal Drive
University Park, IL 60484-3167, U.S.A.

Contents

Safety Message to Installers, Operators, and Maintenance Personnel	5
An Overview of the 120 Series	6
Product Detail	7
Special Conditions for Safe Use	9
Installing the Product.....	10
Accessing the Terminals and Glands	10
Earthing	11
Greasing Holes for the Mounting Face and Screws	12
Wiring the ES4/MS4 Multi-Tone Sounder	13
For 240 Vac Operation.....	13
For 110 Vac Operation.....	13
For 24 Vdc 2-Wire Operation.....	13
For 24 Vdc 3-to-5-Wire Operation	15
For AC 4-to-6-Wire Operation.....	16
240 Vac Operation:	16
110 Vac Operation:	16
Routine Maintenance	17
Technical Service and Support	17
Ordering Replacement Parts	18

Figures

Figure 1: Loudspeaker dimensions.....	9
Figure 2: Dimensions of mounting bracket	10
Figure 3: Side and rear views	11
Figure 4: Tapping	11
Figure 5: Speaker wiring diagram.....	12
Figure 7: Voltage selector for multi-tone sounder	14

Tables

Table 1: Tone chart for 240 Vac, 110 Vac, and 24 Vdc two-wire operation	15
Table 2: Tone chart for 24 Vdc 3-to-5 wire and AC 4-to-6 wire operation.....	17
Table 3: Replacement parts	18

Safety Message to Installers, Operators, and Maintenance Personnel

It is important to follow all instructions shipped with this product. This device is to be installed by a trained electrician who is thoroughly familiar with local codes.

The selection of the mounting location for the device, its controls and the routing of the wiring is to be accomplished under the direction of the facilities engineer and the safety engineer. In addition, listed below are some other important safety instructions and precautions you should follow:

- Read and understand all instructions before installing or operating this equipment.
- Do not connect this unit to the system while the power is on.
- All effective warning speakers produce loud sounds, which may cause in certain situations, permanent hearing loss. You should take appropriate precautions such as wearing hearing protection.
- All effective warning speakers produce loud sounds, which may cause, in certain situations, permanent hearing loss. The device should be installed far enough away from potential listeners to limit their exposure while still maintaining its effectiveness.
- After installation, test the sound system to ensure that it operates properly.
- After testing is complete, provide a copy of these instructions to all operating personnel.
- Establish a procedure to routinely check the speaker installation for integrity and proper operation. Any maintenance must be performed by a trained electrician in accordance with NEC guidelines and local codes.

Failure to follow all safety precautions and instructions may result in property damage, serious injury, or death.

An Overview of the 120 Series

The Federal Signal 120 Series Loudspeaker complies with the ATEX Directive for operation in gaseous hazardous areas classified as Zone 1 with a temperature classification of $-20\text{ }^{\circ}\text{C}$ to $+70\text{ }^{\circ}\text{C}$ T4, $-20\text{ }^{\circ}\text{C}$ to $+55\text{ }^{\circ}\text{C}$ T5, and $-20\text{ }^{\circ}\text{C}$ to $+40\text{ }^{\circ}\text{C}$ T6.

The loudspeakers are designed for use in industrial public address and general alarm applications where ATEX certification is required. They are available in either an ATEX Zone 1 explosion-proof version or a CE compliant, marine-grade industrial version.

The Model 120 Series Loudspeaker, including the marine versions (loudspeaker and MS1), has a main enclosure with dual gland entries and an FLP end cap. The model is fitted with a nose cone, outer and inner horn, driver, and an adjustable mounting bracket. The components within the main enclosure—transformer, transformer and PCB Assembly, PCB—vary depending on the model.

The 25-watt loudspeakers provide an appropriate amount of sound for the ambient environment. Each speaker is transformer-coupled to fine tune the sound output for each application and balance the audio load. Available audio inputs are 100 Vrms, 70 Vrms, and 8 ohms.

A stainless-steel ratcheted mounting bracket locks the sounder in position at a specific angle without slipping. The bottom surface of the mounting bracket also contains three mounting holes, to adapt to a variety of surfaces.

The loudspeaker is rated for IP66/67 according to EN60529 through the use of a neoprene O-ring seal. All exterior cast aluminum surfaces are finished in powder coat paint and external hardware is manufactured from stainless steel to resist corrosion.

Product Detail

Frequency Range:

Explosion Proof
350–4000 Hz

Marine
300–3700 Hz

Ambient Temperature Range:

**T4 Explosion Proof
and Marine**
–20 °C to +70 °C

**T5 Explosion
Proof**
–20 °C to +55 °C

**T6 Explosion
Proof**
–20 °C to +40 °C

Explosion Proof Rated:

Sound Pressure Level at 1 kHz (full power at 1 meter)

25W-11B:
123 dBa

Sound Pressure Level at 1 kHz (1 watt at 1 meter)

25W-11B:
123 dBa

Marine Rated Power:

Sound Pressure Level at 1 kHz (full power at 1 meter)

125 dBa

Sound Pressure Level at 1 kHz (1 watt at 1 meter)

107 dBa

Certifications and Approvals:

Nemko 05ATEX1036 II 2 G Ex d IIB T4...T6 Gb

IEC IECEx NEM 04.0002

Marine:

Electromagnetic compatibility to EN 61000-6-1, 2, 3, 4: 2001

E_x Standards:

EN 60079-0: 2009

EN 60079-1: 2007

EN 60079-7: 2007

CE:

EMC to EN 61000-6-1,2,3,4:2001

LVD to EN 60065

Ingress Protection:

Explosion Proof IP66 and IP67-EN60529

Marine IP66 and IP67-EN60529

Specifications:

Net Weight	Exd Model: 6.4 kg (14.1 lb) Exde Model: 6.5 kg (14.3 lb)
Shipping Dimensions	32 cm x 30 cm x 38 cm (12.6 in x 11.8 in x 115.0 in)
Dispersion Angle	120 degrees
Type	Dual entry
Gland Entries	2 x M20 x 1.5 mm
Cable Terminations	6A, 1.5 mm conductors
Mounting	Unpainted stainless steel bracket
Body and Horn Material	Marine grade aluminum alloy
Audio Input	100 volt, 70 volt, and 8 ohms
Power Capacity	25 W

⚠ WARNING

FIRE/EXPLOSION HAZARD

Do not use the 120 Series in flammable atmospheres containing carbon disulphide (CS₂). All units are not certified for use in flammable atmospheres containing carbon disulphide.

Failure to observe this warning could result in serious injury or death.

⚠ WARNING

SHOCK HAZARD

Do not connect this unit to the system while the power is on. Failure to heed this warning could cause serious injury or death.

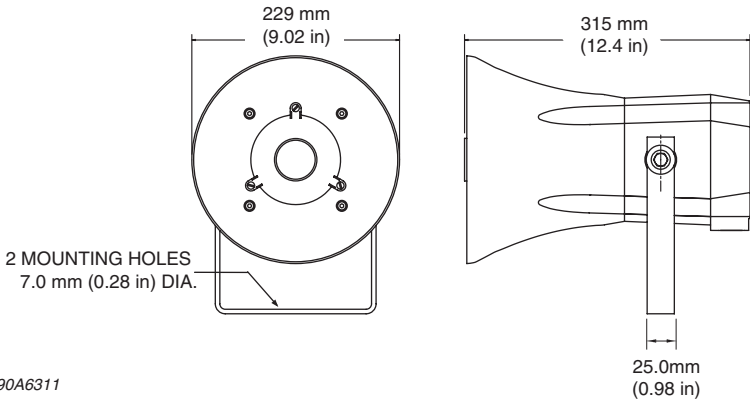
Figure 1 Loudspeaker dimensions

290A6311

Special Conditions for Safe Use

To maintain the loudspeaker certification, do not attempt to repair the flameproof enclosure. Units requiring repair to the flameproof enclosure must be returned to Federal Signal for service.

The maximum flame path gap for the IIB variants is the same as for gas group IIC.

All terminal screws, used or unused, must be tightened 0.5 N • m to 0.7 N • m.

Check label details to ensure the unit is of the correct electrical rating and hazardous area classification.

For permanently connected equipment located in safe areas, the equipment supply should be provided via a disconnect device located in close proximity to the equipment and within easy reach of the operator, which is marked as the disconnecting device for the equipment.

For permanently connected equipment located in a hazardous area, the equipment supply should be provided via a disconnect device located in a safe area or via a suitable ATEX approved disconnect device located in close proximity to the equipment, which is marked as the disconnecting device for the equipment.

Where the disconnect device takes the form of a circuit breaker it must be properly sized for the required current. The wiring feeding the equipment must be properly sized for the required current.

Recommended cable specification: Elastomeric insulated and braided armored for fixed wiring in ships and offshore units to BS6883 or IEC92-3.

Maximum core size: 2.5 mm²

Recommended cable gland: Hawke 501/453/univ or equivalent

Installing the Product

This product must be installed and maintained only by qualified personnel who have received the relevant training. During installation ensure that all external screw threads and flameproof faces are suitably greased. Recommended torque on all external fixings is 5 N • m. Check details on the label to ensure the unit is of the correct electrical rating and hazardous area classification.

Ensure the unit is securely mounted using the supplied bracket. Use M12 for the center hole and/or 2 x M6 in the outer holes (Figure 2 on page 9). You can adjust the angle of the loudspeaker by using the external ratcheted brackets on each side of the body (Figure 3 on page 11).

Figure 2: Dimensions of mounting bracket

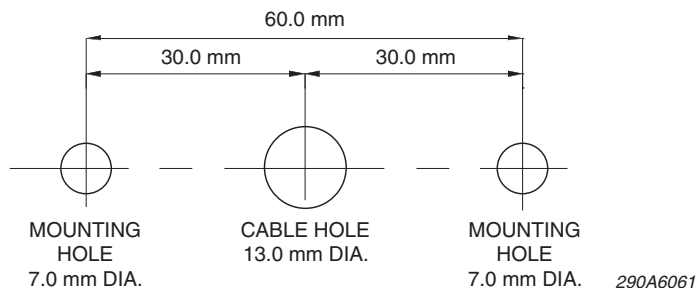

Accessing the Terminals and Glands

To access the cable terminals remove the end cap by first removing the four M5 socket-head cap screws (Figure 3 on page 11).

The M20 gland entry is located in the main enclosure. Ensure the cable is terminated in accordance with the gland manufacturer's instructions using approved cable glands. Any unused entry must be sealed with a suitably certified stopper plug.

NOTE: Loudspeakers in close proximity must be connected in the same phase.

Figure 3 Side and rear views

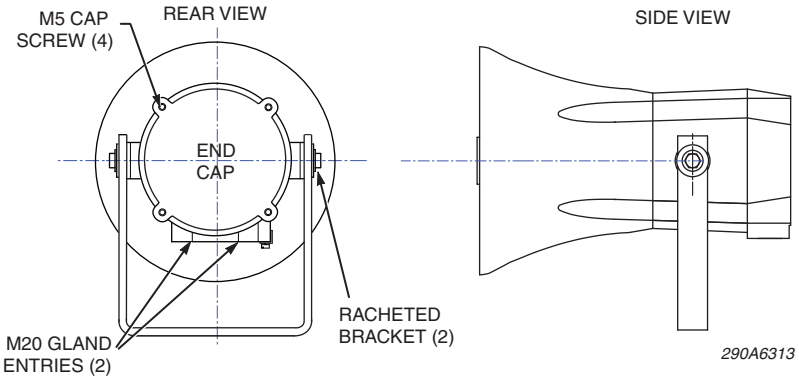
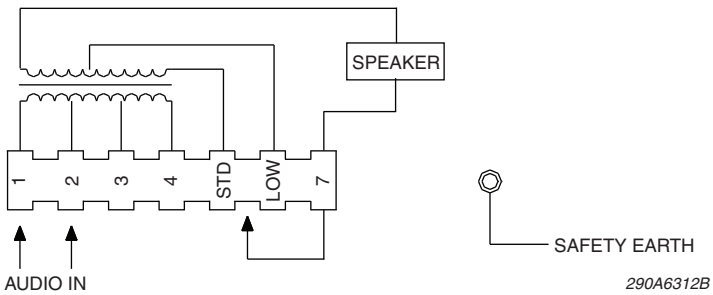

Figure 4 Tapping

TRANSFORMER TAPPINGS		
TERMINALS	STD	LOW
1 AND 2	25 W	2.0 W
1 AND 3	20 W	1.5 W
3 AND 4	15 W	1.0 W
2 AND 4	10 W	0.6 W
1 AND 4	5 W	0.2 W

NOTE: ENSURE THE SOUNDER IS EARTHED USING ONE OF THE REQUIRED EARTHING POINTS



Earthing

The unit must be correctly connected to earth. Both internal and external earth terminals are provided.

Figure 5 Speaker wiring diagram

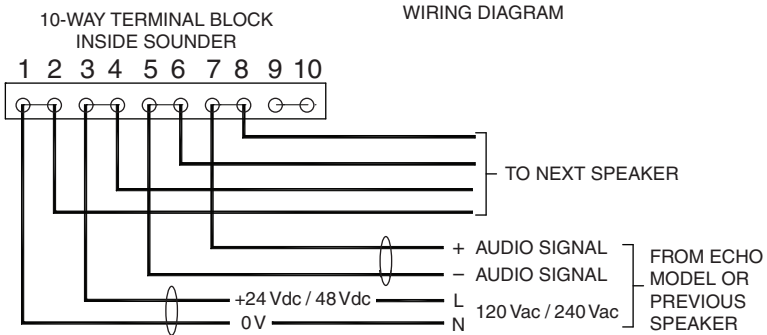
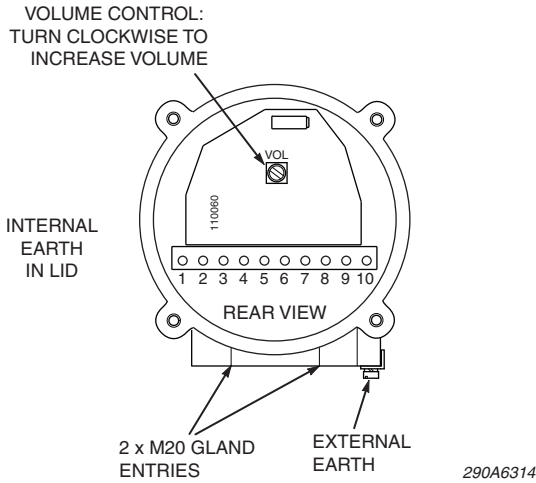

Greasing Holes for the Mounting Face and Screws

Before the installation you must grease all holes for the O-ring mounting face and screws.

When you are finished installing the speaker, install the O-ring and end cap, ensuring that there are no trapped wires. Tighten the end cap using all four stainless-steel screws to 5 to 7 N • m.

Wiring the ES4/MS4 Multi-Tone Sounder

This section provides instructions for operating the Multi-Tone Sounder at 240 Vac, 110 Vac, and 24 Vdc.

Also included are instructions for 24 Vdc 2-wire operation, 24 Vdc 3-to-5-wire operation, and AC 4-to-6-wire operation. See Figures 6 and 7 on page 14 and the Table 1 on page 15.

For 240 Vac Operation

1. Set the Voltage Selector to 230 V.
2. Insert the 500 mA fuse.
3. Turn the tone selector to the position of the tone you want.
4. Connect the Live wire to the LIVE IN terminal.
5. Connect the Neutral wire to the NEUTRAL IN terminal.
6. Connect the Internal Earth wire to the INTERNAL EARTH terminal.

For 110 Vac Operation

1. Set the Voltage Selector to 110 Vac.
2. Insert the 1 A fuse.
3. Turn the tone selector to the position of the tone you want.
4. Connect the Live wire to the LIVE IN terminal.
5. Connect the Neutral wire to the NEUTRAL IN terminal.
6. Connect the Internal Earth wire to the INTERNAL EARTH terminal.

For 24 Vdc 2-Wire Operation

1. Turn the tone selector to the position of the tone you want.
2. Connect to the 0V common terminal.
3. Connect the +24 Vdc wire to the +24V IN terminal.
4. Connect the Internal Earth wire to the INTERNAL EARTH terminal.

Figure 6 Sounder wiring diagram

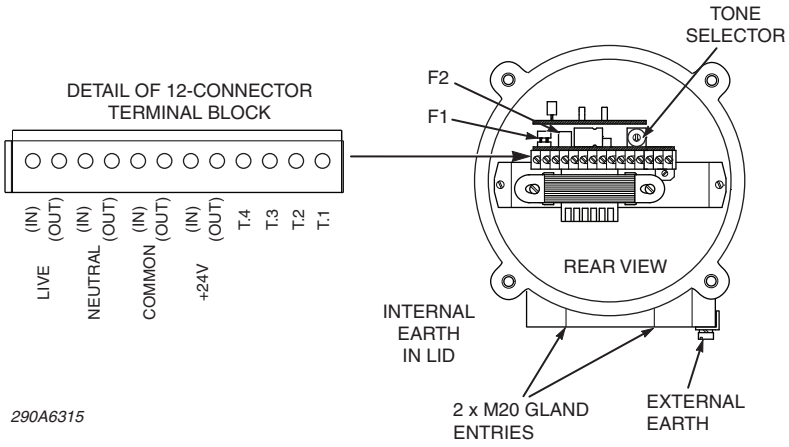

Figure 7 Voltage selector for multi-tone sounder

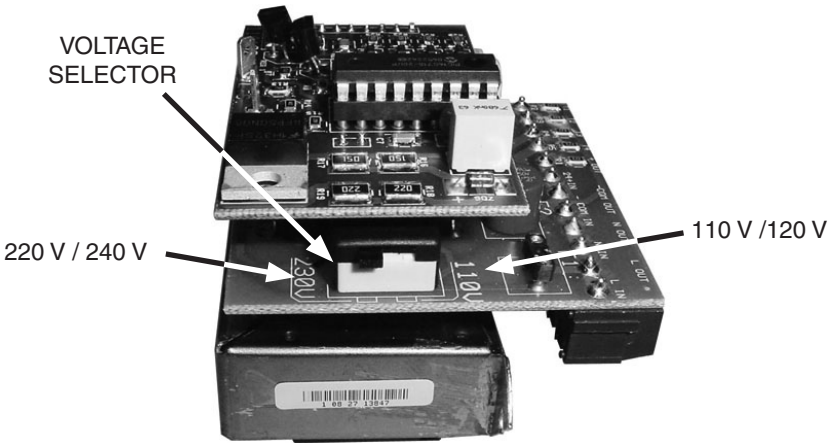

Table 1 Tone chart for 240 Vac, 110 Vac, and 24 Vdc two-wire operation

Position	Tone
0	OFF
1	Two tones: 588 Hz for 0.25 second, 714 Hz for 0.25 second
2	Swept 600 Hz > 700 Hz in 0.5 second
3	Telephone warble
4	Constant 700 Hz
5	Simulated bell, three rings per second
6	Swept 1.2 kHz > 1.6 kHz, swept 1.6 kHz > 1.2 Hz, six cycles per second
7	Two tones: 1 kHz for 0.4 second, 700 Hz for 0.4 sec.
8	700 Hz for 0.25 second, silence for 0.25 second
9	Swept 400 Hz > 1.6 Hz in 1 second, constant 1.2 Hz for 2 second
A (10)	Swept 500 Hz 770 Hz in 0.5 second.
B (11)	1 kHz for 1 second, silence for 1 second
C (12)	Constant 1 kHz
D (13)	Two tones: 700 Hz for 0.5 second, 500 Hz for 0.5 second
E (14)	Warble between 1 kHz and 1.4 kHz approx. 10 cycles per second
F (15)	Swept 1.2 kHz > 400 Hz in 1 second

For 24 Vdc 3-to-5-Wire Operation

See Figure 6 and 7 on page 14 and the Table 2 on page 17.

1. Turn the tone selector to 0.
2. Connect to the 0 V common terminal.
3. Connect the +24 Vdc supply/select wires to the T1, T2, T3, T4 terminals. These connections enable you to select the four basic tones remotely.
4. Connect the Internal Earth wire to the INTERNAL EARTH terminal.

For AC 4-to-6-Wire Operation

See Figure 6 and 7 on page 14 and the tone chart on page 17.

240 Vac Operation:

1. Set the Voltage Selector to 230 V.
2. Insert the 250 mA fuse,
3. Turn the Tone Selector to the 0 position.
4. Connect the Live wire to the LIVE IN terminal.
5. Connect the Neutral wire to the NEUTRAL IN terminal.
6. Connect the Internal Earth wire to the INTERNAL EARTH terminal.
7. Connect a link between the NEUTRAL OUT and +24V OUT terminals.
8. In the control panel connect from Neutral return through SELECT LINES. These connections enable you to remotely select the four basic tones.
9. Connect wires to the T1, T2, T3, and T4 terminals as needed.

110 Vac Operation:

1. Set the Voltage Selector to 110 V.
2. Insert the 500 mA fuse,
3. Turn the Tone Selector to the 0 position.
4. Connect the Live wire to the LIVE IN terminal.
5. Connect the Neutral wire to the NEUTRAL IN terminal.
6. Connect the Internal Earth wire to the INTERNAL EARTH terminal.
7. Connect a link between the NEUTRAL OUT and +24V OUT terminals.
8. In the control panel connect from Neutral return through SELECT LINES. These connections enable you to remotely select the four basic tones.
9. Connect wires to the T1, T2, T3, and T4 terminals as needed.

Table 2

Tone chart for 24 Vdc 3-to-5 wire and AC 4-to-6 wire operation

Terminal	Tone
T1	Two tones: 588 Hz for 0.25 second, 714 Hz for 0.25 second
T2	Swept 600 Hz > 700 Hz in 0.5 second
T3	Constant 700 Hz
T4	700 Hz for 0.25 second, silence for 0.25 second

Routine Maintenance

WARNING

FIRE/EXPLOSION HAZARD

Do not open the loudspeaker and/or sounder, even they are isolated, when a flammable-gas atmosphere is present.

Failure to observe this warning could result in serious injury or death.

Ensure that the unit is maintained in line with the regulations in force and at least once per year.

- ✓ Check for external damage and corrosion and repair and replace as required.
- ✓ Check for water ingress and replace the O-rings if necessary.
- ✓ Check all earth connections.
- ✓ Check flameproof paths and fixing screws for damage and corrosion.
- ✓ Grease all threads, O-rings, and flameproof paths.

Technical Service and Support

For technical service and support, please contact:

Federal Signal Corporation
 Integrated Systems
 Service Department
 2645 Federal Signal Drive
 University Park, IL 60484-3167, U.S.A.
 Phone: +1 877 289 3246
 Fax: +1 708 534 4887
 E-Mail: systems@fedsig.com

Ordering Replacement Parts

To order the replacement parts in *Table 3*, please contact the Service Department. When removing any of the subassemblies ensure that you do not break the two flying leads from the voice coil.

Table 3: Replacement parts

Description	Part Number
Mounting Bracket	K8597108
Ratchet Fixing Kit	K8597225
Cap Screw	K7000496-30
O-Ring Kit	K8597226
PCB, 100 V ISMT Module, 25 W	K2001974
PCB, Sounder Module, 25 W	K2005360
PCB, Powered Speaker, 25 W, 24 Vdc	K2001975
PCB, Powered Speaker, 25 W, 120 Vdc	K2001975-02
PCB, Powered Speaker, 25 W, 240 Vdc	K2001975-03
Transformer, 100 V	K1461683-01
Transformer, 70 V	K1461683
Driver Assembly, 25 W	K8597168



Federal Signal Corporation
Integrated Systems
2645 Federal Signal Drive
University Park, IL 60484-3167, U.S.A.

© 2010 Federal Signal Corporation