



Intrinsically Safe Sounder

Model WAS-IS

Model WAS-IS is a compact, 100dB(A) alarm sounder. Approvals include ATEX and IECEx for Zone 0 applications and FM approval for Class I Division 1 and Class I Zone 0 applications.

The WAS-IS is suitable for all intrinsically safe signalling applications including fire, security and process control.

FEATURES:

- Input overload and reverse current protection
- Auto synchronised sound output
- Available with custom tone configurations and frequencies.

APPROVALS:

- ATEX certificate: Sira10ATEX2102X
EN 60079-0 : 2006 EN 60079-11 : 2007
EN 60079-26 : 2007
- IECEx certificate: IECEx SIR 10.0046X
IEC 60079-0 : 2007 IEC 60079-11 : 2006
IEC 60079-26 : 2006
- FM approved
Class 3600 1998 Class 3610 1999
Class 3810 2005
- VdS approved to EN54-3 (CPD 89/106/EEC).

Model	Voltage	Voltage Range	Operating Current
WAS-IS	24VDC	16-28VDC	25mA

HOW TO ORDER

WAS-IS

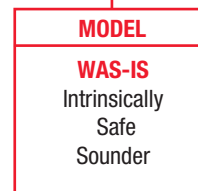

INTRINSICALLY SAFE SOUNDER (WAS-IS)

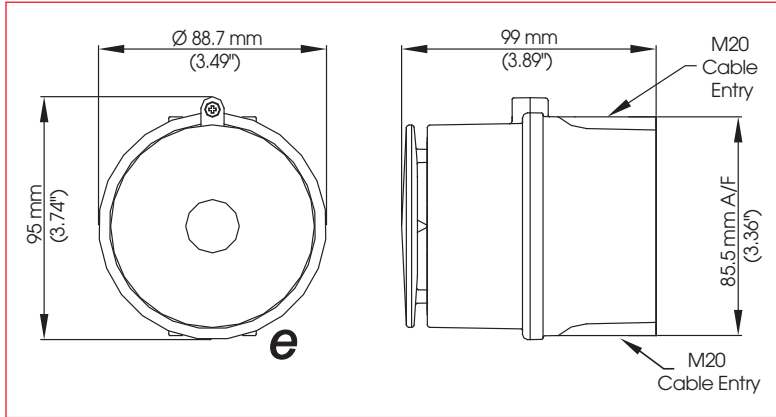

May be powered from any certified Zener barrier or galvanic isolator whose output parameters do not exceed:

Uo: 28VDC

Io: 93mA

Po: 660mW

Also available as a combined alarm sounder and LED beacon the WAV-IS unit.



SPECIFICATIONS

ATEX / IECEx / FM:	II 1G Ex ia IIC T4 Ga (-40°C ≤ Ta ≤ +60°C)
	IS Class I, Zone 0, AEx ia IIC T4
	IS Class I, Division 1, Groups A, B, C, D
Nominal output:	100dB(A) @ 1m +/- 3dB - Tone 2*
No. of tones:	49 (UK00A/PFEER compliant)
No. of stages:	3
Volume control:	Max. 100dB(A); Min. 90dB(A) - Tone 2
Voltage:	16-28vdc via Zener barrier or galvanic isolator
Current:	25mA typical when powered from 24V supply via 28v 300 Ohm Zener barrier
Ingress protection:	IP65
Rating:	Continuous
Housing material:	UL94V0 & 5VA FR ABS
Housing color:	RAL3000 Red
Fixings:	Stainless Steel
Cable entries:	2 x M20 clearance gland knockouts. Custom configurations also available.
Terminals:	0.001 to 0.098" 0.5 to 2.5mm²
Operating temp:	-104°F to +140°F -40°C to +60°C
Storage temp:	-104°F to +158°F -40°C to +70°C
Relative humidity:	90% at 68°F 90% at 20°C
Product weight:	0.23 Kg
Shipping weight:	0.38 Kg

TONES

Stage	Frequency Description	Stage 2	Stage 3
Tone 1	340 Hz Continuous	Tone 2	Tone 5
Tone 2	800/1000Hz @ 0.25 sec Alternating - BS5839 Alarm tone	Tone 17	Tone 5
Tone 3	500/1200Hz @ 0.3Hz 0.5 sec Slow Whoop - NEN 2575:2000	Tone 2	Tone 5
Tone 4	800/1000Hz @ 1Hz Sweeping	Tone 6	Tone 5
Tone 5	2400Hz Continuous	Tone 3	Tone 20
Tone 6	2400/2900Hz @ 7Hz Sweeping	Tone 7	Tone 5
Tone 7	2400/2900Hz @ 1Hz Sweeping	Tone 10	Tone 5
Tone 8	500/1200/500Hz @ 0.3Hz Sweeping	Tone 2	Tone 5
Tone 9	1200/500Hz @ 1Hz - DIN / PFEER P.T.A.P.	Tone 15	Tone 2
Tone 10	2400/2900Hz @ 2Hz Alternating	Tone 7	Tone 5
Tone 11	1000Hz @ 1Hz Intermittent	Tone 2	Tone 5
Tone 12	800/1000Hz @ 0.875Hz Alternating	Tone 4	Tone 5
Tone 13	2400Hz @ 1Hz Intermittent	Tone 15	Tone 5
Tone 14	800Hz 0.25sec on, 1 sec off Intermittent	Tone 4	Tone 5
Tone 15	800Hz Continuous	Tone 2	Tone 5
Tone 16	660Hz 150mS on, 150mS off Intermittent	Tone 18	Tone 5
Tone 17	544Hz (100mS)/440Hz (400mS) - AFNOR NF S 32-001	Tone 2	Tone 27
Tone 18	660Hz 1.8sec on, 1.8sec off Intermittent	Tone 2	Tone 5
Tone 19	1.4KHz-1.6KHz 1s, 1.6KHz-1.4KHz 0.5s - AFNOR NFC48-265	Tone 2	Tone 5
Tone 20	660Hz Continuous	Tone 2	Tone 5
Tone 21	554Hz/440Hz @ 1Hz Alternating	Tone 2	Tone 5
Tone 22	544Hz @ 0.875 sec. Intermittent	Tone 2	Tone 5
Tone 23	800Hz @ 2Hz Intermittent	Tone 6	Tone 5
Tone 24	800/1000Hz @ 50Hz Sweeping	Tone 29	Tone 5
Tone 25	2400/2900Hz @ 50Hz Sweeping	Tone 29	Tone 5
Tone 26	Bell	Tone 2	Tone 15
Tone 27	554Hz Continuous	Tone 26	Tone 5
Tone 28	440Hz Continuous	Tone 2	Tone 5
Tone 29	800/1000Hz @ 7Hz Sweeping	Tone 7	Tone 5
Tone 30	300Hz Continuous	Tone 2	Tone 5
Tone 31	660/1200Hz @ 1Hz Sweeping	Tone 26	Tone 5
Tone 32	Two tone chime.	Tone 26	Tone 15
Tone 33	745Hz @ 1Hz Intermittent	Tone 2	Tone 5
Tone 34	1000 & 2000Hz @ 0.5 sec Alternating - Singapore	Tone 38	Tone 45
Tone 35	420Hz @ 0.625 sec Australian Alert	Tone 36	Tone 5
Tone 36	500-1200Hz 3.75sec /0.25sec. Australian Evac.	Tone 35	Tone 5
Tone 37	1000Hz Continuous - PFEER Toxic Gas	Tone 9	Tone 45
Tone 38	2000Hz Continuous	Tone 34	Tone 45
Tone 39	800Hz 0.25sec on, 1 sec off Intermittent	Tone 23	Tone 17
Tone 40	544Hz (100mS)/440Hz (400mS) - NF S 32-001	Tone 31	Tone 17
Tone 41	Motor Siren - slow rise to 1200 Hz	Tone 2	Tone 5
Tone 42	Motor Siren - slow rise to 800 Hz	Tone 2	Tone 5
Tone 43	1200 Hz Continuous	Tone 2	Tone 5
Tone 44	Motor Siren - slow rise to 2400 Hz	Tone 2	Tone 5
Tone 45	1KHz 1s on, 1s off Intermittent - PFEER Gen. Alarm	Tone 38	Tone 34
Tone 46	1200/500Hz @ 1Hz - DIN / PFEER P.T.A.P.	Tone 47	Tone 37
Tone 47	1KHz 1s on, 1s off Intermittent - PFEER Gen. Alarm	Tone 46	Tone 37
Tone 48	420Hz @ 0.625 sec Australian Alert	Tone 49	Tone 5
Tone 49	500-1200Hz 3.75sec /0.25sec. Australian Evac.	Tone 26	Tone 37