

VEHICULAR BACK-UP ALARMS

Models EBA and EPBA



STATE OF THE ART, BACK-UP ALARMS

- Single and dual function models
- Dual function feature for selectable tone (EPBA)
- Impact resistance housing
- Universal mounting bracket included
- Low amp draw
- Sealed against moisture and contaminants
- Protected against voltage spikes
- State of the art technology and components

The Evacuator® back-up alarm offers superior reliability with exceptional warning power. Evacuator alarms utilize piezo-electric circuitry and solid-state components to minimize the effects of vibration and reduce amp draw. To seal out moisture and contaminants, the unique nickel-plated terminal inserts are hermetically sealed, and the housing is environmentally sealed.

The Evacuator Plus back-up alarm is the only alarm that includes a state-of-the-art dual function feature (patent pending). The dual function feature allows the alarm to produce two distinctly different tones by reversing the polarity of the wiring. Normal polarity produces a "Pulsed" tone, which is an intermittent signal that is primarily use for back-up warning. Reversed polarity produces a "Constant-On" tone, which is a continuous signal that can be used to signal motion such as the lifting of a truck platform or gate.

The alarm is designed for multi-volt operation and meets SAE and OSHA requirements for motor vehicles and material handling equipment. All models include a universal mounting bracket.

Motage	Voltage	Operating Current	Sound Output	Sound Frequency
EBA	12-24VDC	0.04 amps	97dB	2.35kHz
EPBA	9-48VDC	0.03 amps	97dB	2.4kHz



VEHICULAR BACK-UP ALARMS (EBA/EPBA)

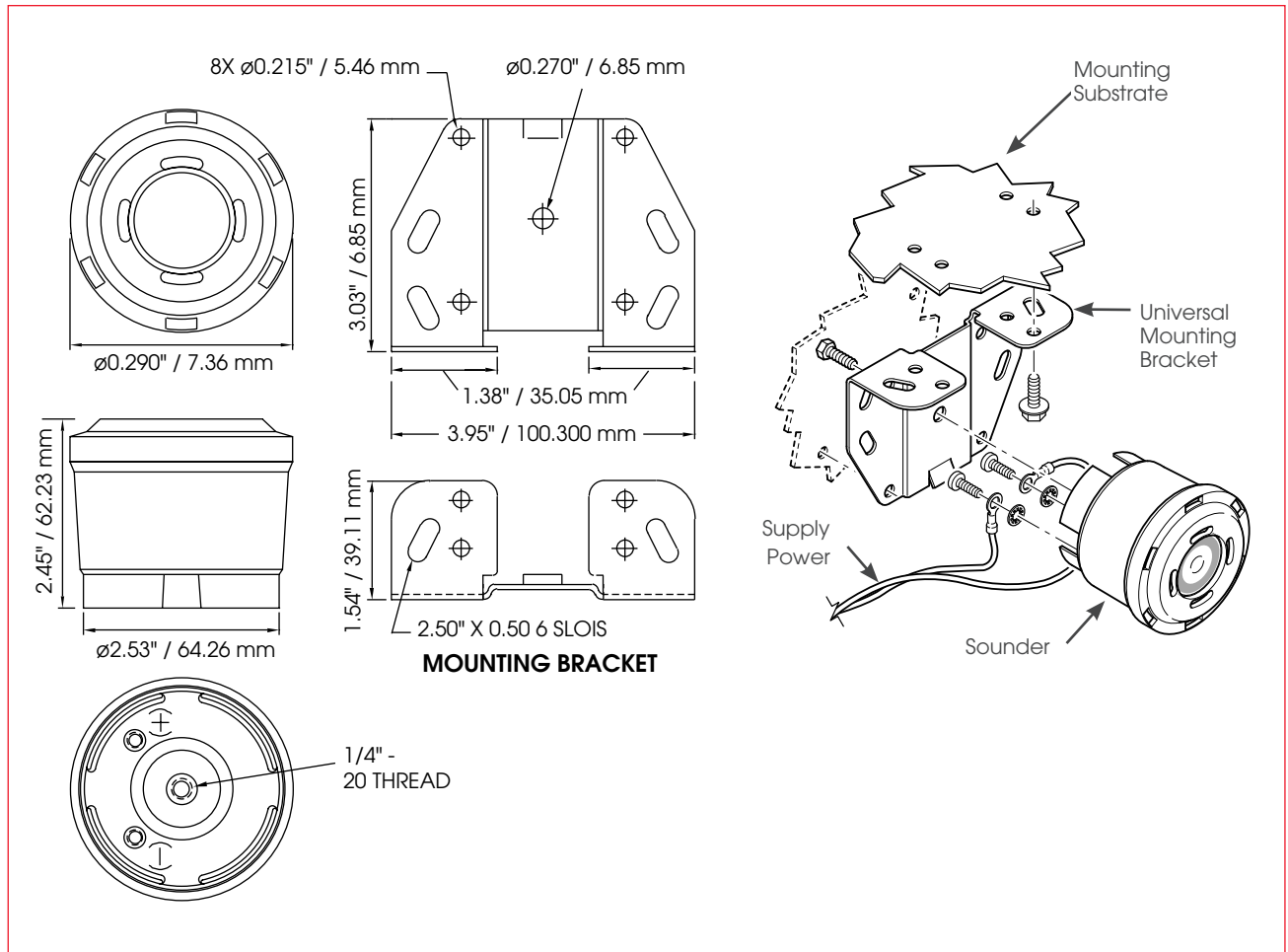

SPECIFICATIONS

Operating Temperature:	-40°F to 165°F	-40°C to 74°C
Length:	2.9"	73.0 mm
Width:	2.9"	73.0 mm
Height:	2.4"	62.0 mm
Weight:	0.6 lbs.	0.3 kg
Shipping Weight:		
EBA	0.6 lbs.	0.3 kg
EPBA	0.6 lbs.	0.3 kg

HOW TO ORDER

- Specify model
- Please refer to Model Number Index EBA/EPBA beginning on page 376