



Explosion-Proof General Alarm Siren

Model AX

DESIGNED FOR USE IN EXPLOSION PROOF ATMOSPHERES

- Available with 120VAC/125VDC universal motor
- Produces 105dBa @ 10' (115dBa @ 1m)
- Wall mount
- Maintenance free
- Type 3R enclosure
- UL and cUL Listed and CSA Certified

The Federal Signal Model AX siren was introduced in 1937 and received UL listing in 1938. This high pitched siren features a unique rotor and stator design that produces a distinctive tonal quality.

The universal motor operates on 120VAC or 125VDC. This siren features oversized ball bearings which are lubricated for the life of the siren, eliminating periodic maintenance.

The Model AX is UL listed for use in Class I, Division 1, Groups C and D; Class II, Division 2, Groups E, F, & G; and Class III locations. This siren is cUL Listed and CSA Certified.

Model	Voltage	Operating Current	Decibels @		Frequency
			10'	1m	
AX-120SB	120VAC/VDC	1.9 amps	105	115	1830Hz

Hazardous Location Rating:

Hazardous Location	T-Code at Maximum Ambient Temperature, °C	
	40°C	66°C
Class I, Groups C & D	T4A/120°	T4/135°
Class II and Class III	T4/135°	T3C/160°



EXPLOSION PROOF ALARM SIREN (AX)

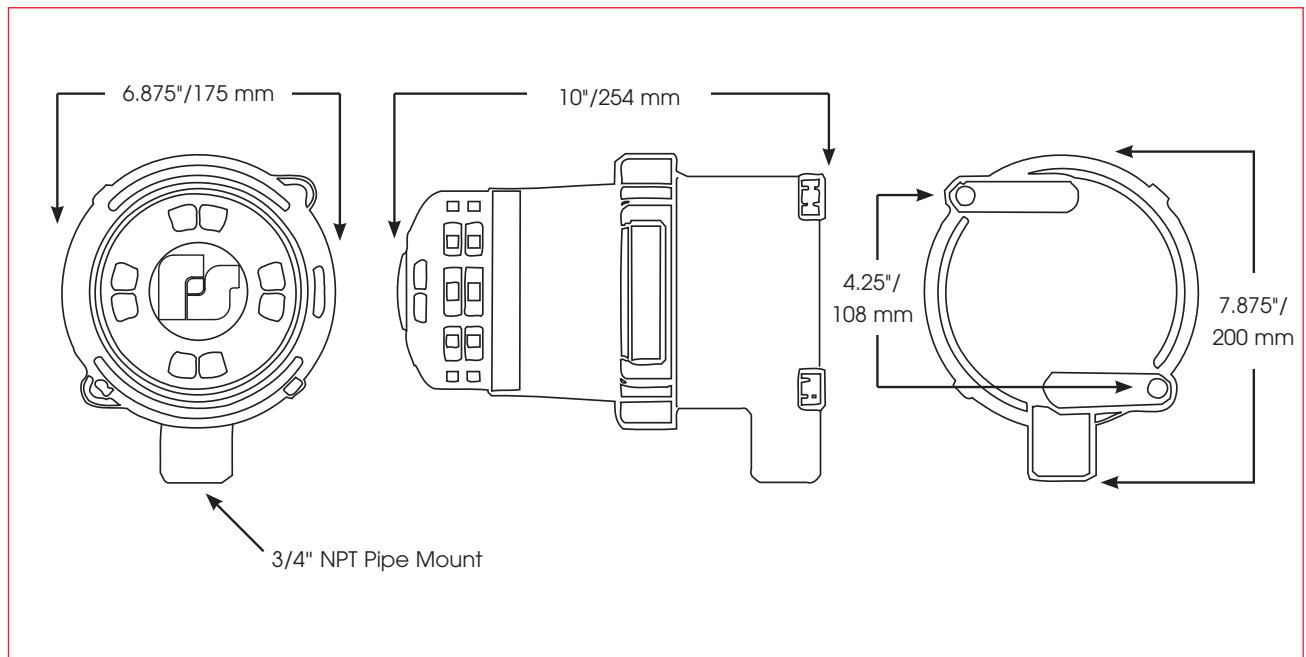

SPECIFICATIONS

Operating Temperature:	-13°F to 150°F	-25°C to 65°C
Motor:	Universal	Universal
Net Weight:	10.0 lbs	4.5 kg
Shipping Weight:	13.4 lbs	6.1 kg
Height:	7.875"	200.0 mm
Width:	6.875"	175.0 mm
Depth:	10.0"	254.0 mm

HOW TO ORDER

- Specify model
- Please refer to Model Number Index AX beginning on page 375

REPLACEMENT PARTS

<u>Description</u>	<u>Part Number</u>
Motor	K8242C074B