

Resonating Horn

Model 52



DESIGNED FOR OFF-ROAD VEHICLES

- Available in 24VDC
- Withstands extreme outdoor conditions
- Produces 114dBa @ 10' (124dBa @ 1m)
- Surface mount with flanges
- Type 4X enclosure

The Federal Signal Model 52 resonating horn produces 114dBa @ 10 feet (124dBa @ 1m) with a 1,000 foot range. It is capable of penetrating high ambient noise levels. Being electrically-activated, the Model 52 does not require an air compressor for operation. The Model 52 is able to withstand the shocks, vibrations, dust and atmospheric conditions encountered in off-road use. The operating temperature range is -40°F to 185°F (-40°C to 85°C).

Rubber gaskets and a power connector make the Model 52 completely watertight. The projector and internal parts are made of zinc-coated steel or stainless steel to resist corrosion; the exterior is sealed with gray enamel paint. The housing is die-cast aluminum. Tied and adhesive-bonded internal wiring helps prevent electrical shorts, wire breakage, and loose connections. The Model 52 is available in 24VDC. It's 18-32V operating range allows for voltage inconsistencies. The Model 52 has a duty cycle of five minutes on and five minutes off.

Federal Signal's Model 52 resonating horn is specifically designed for off-road vehicles. It provides the very loud sound for which an air-horn is usually required, but without the need for an expensive compressor.

Used by major manufacturers of construction equipment, Model 52 resonating horns suit the warning needs of any off-road vehicle working in a high noise environment, including excavators, backhoes, compactors (steamrollers), loaders, tractors, bulldozers, trenchers, and scrapers.

Model	Voltage	Operating Current	Decibels @	
			10'	1m
52-024-1	24VDC	4.0 amps	114	124



RESONATING HORN (52)

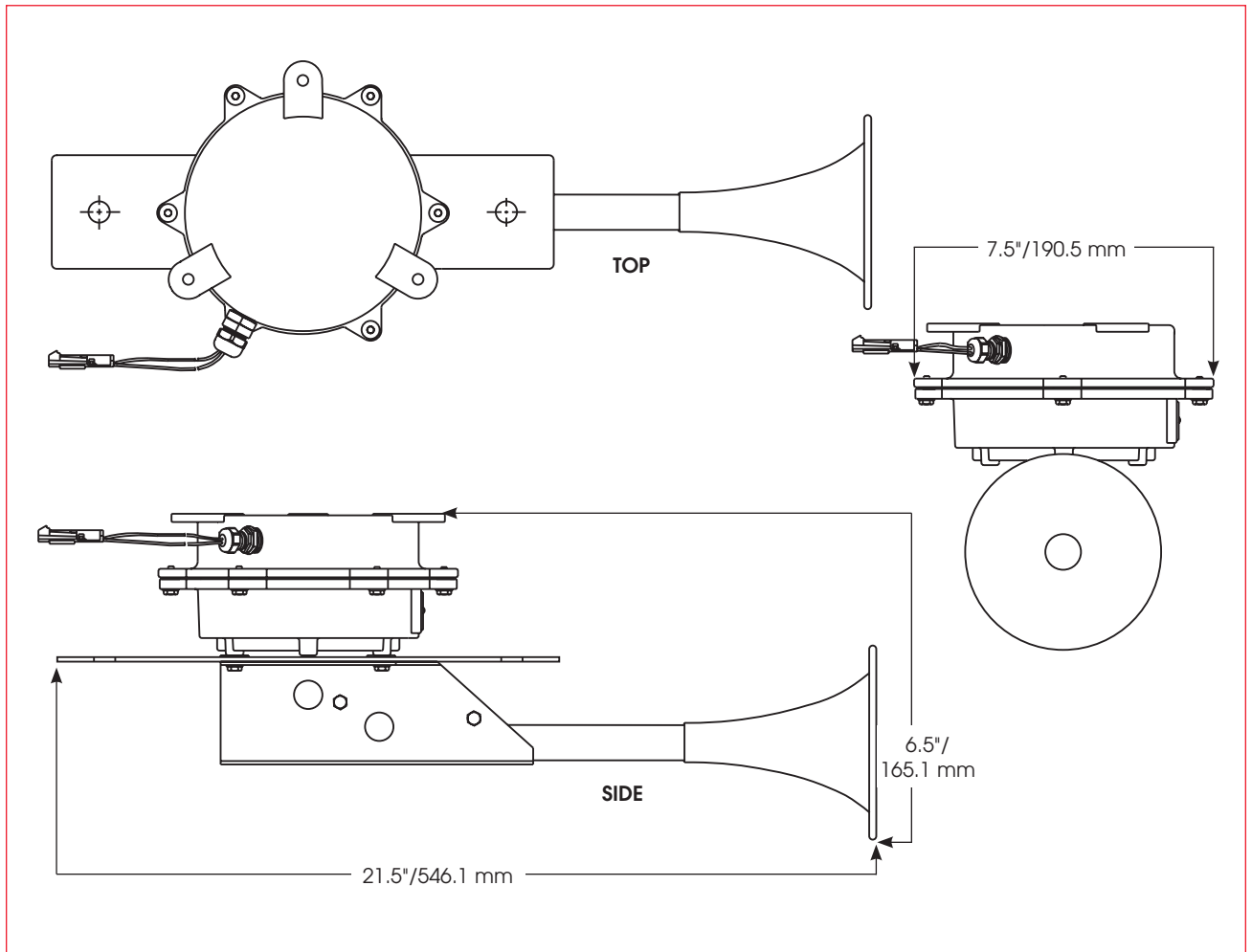

SPECIFICATIONS

Operating Temperature:	-40°F to 185°F	-40°C to 85°C
Net Weight:	9.0 lbs.	4.08 kg
Shipping Weight:	10.0 lbs.	4.54 kg
Height:	6.5"	165.1 mm
Width:	7.5"	190.5 mm
Depth:	21.5"	546.1 mm

HOW TO ORDER

- Specify model and voltage
- Please refer to Model Number Index 52 beginning on page 374

REPLACEMENT PARTS

<i>Description</i>	<i>Part Number</i>
Projector, Straight	K8233C081B-02